



VILLAGE OF FOREST PARK COUNCIL MEETING AGENDA

Monday, August 12, 2024
Lower Level of Village Hall
7:00 PM

In-Person and Via Live Stream

Dial-In Live Stream: 312-626-6799; Webinar ID 813 8425 0048; Passcode 138967 or click [here](#):

PLEDGE OF ALLEGIANCE

ROLL CALL

APPROVAL OF THE MINUTES FROM THE JULY 22, 2024 ANNUAL APPROPRIATION ORDINANCE HEARING

APPROVAL OF THE MINUTES FROM THE JULY 22, 2024 REGULAR MEETING OF THE COUNCIL

PUBLIC COMMENT: - emailed public comment can be sent to the village clerk at ybelmonte@forestpark.net prior to 6:30 p.m. the day of the meeting

COMMUNICATIONS:

DEPARTMENT REPORTS:

1. Fire Department

BILLS BY RESOLUTION

UNFINISHED BUSINESS:

NEW BUSINESS:

1. Ordinance waiving bid and authorizing the purchase of a fully equipped 2023 Ford F350 utility truck with buildout
2. Resolution authorizing the execution of a legal services engagement agreement with Sonnenschein Groupe, LLC to represent the Village of Forest Park with respect to the Payment Card Interchange Fee and Merchant Discount Antitrust Litigation Matter
3. Resolution approving Pay Request #1 for the 2024 Green Alley Improvements Project from J. Nardulli Concrete, Inc. (800 & 900 Block of Circle-Marengo Alley)
4. Resolution authorizing acceptance and execution of an Illinois Department of Transportation Sustained Traffic Enforcement Program (STEP) for High Visibility Enforcement (HVE) Grant for FY 2025
5. Resolution authorizing and accepting a Grant Agreement by and between the Illinois Department of Revenue and the Village of Forest Park for the FY 2025 Tobacco Enforcement Program Grant
6. Resolution re-approving the specifications and re-authorizing the advertising of bids for the Village of Forest Park 2024 Lead Service Replacement Project
7. Approval: Community Center Senior Trip Contracts: Paramount Theater & Drury Lane
8. Approval: Request for Use of Public Way: Tool of North America & Forest Park Chamber of Commerce Sidewalk Sale
9. Approval: Request for Solicitation by Knights of Columbus Tootsie Roll Days
10. Approval: Banner requests – Forest Park Chamber Sidewalk Sale and Forest Park Theater Group Shakespeare in the Park (ratification)

ADMINISTRATOR'S REPORT

COMMISSIONER REPORTS

ADJOURNMENT

JULY 22, 2024
PUBLIC HEARING
THE ANNUAL APPROPRIATION ORDINANCE OF THE
VILLAGE OF FOREST PARK FOR THE
FISCAL YEAR BEGINNING MAY 1, 2024 AND
ENDING APRIL 30, 2025

The Village Council of the Village of Forest Park, Cook County, Illinois, convened at 6:45 PM on Monday, July 22, 2024, to receive public comment on the proposed Appropriation Ordinance, appropriating the amounts of money, or as much thereof as may be allowed by law, for the several municipal projects and purposes for the fiscal year beginning May 1, 2024 and ending April 30, 2025.

ROLL CALL

Commissioners Maxham, Nero, Melin-Rogovin, Voogd and Mayor Hoskins answered the Roll Call.

PUBLIC COMMENT

None

ADJOURNMENT

There being no further business to be addressed, Mayor Hoskins called for a motion to adjourn the Public Hearing concerning the Appropriation Ordinance for Fiscal Year May 1, 2024 to April 30, 2025.

Commissioner Melin-Rogovin motioned to adjourn the public hearing and Commissioner Maxham seconded the motion.

AYES: Commissioners, Maxham, Nero, Melin-Rogovin, Voogd and Mayor Hoskins

NAYS: None

ABSENT: None

The motion carried unanimously. The Hearing adjourned at 6:49 PM.

Respectfully submitted,

Vanessa Belmonte, Village Clerk

**THE REGULAR MEETING OF THE COUNCIL OF THE
VILLAGE OF FOREST PARK, COOK COUNTY, ILLINOIS
HELD ON MONDAY EVENING, JULY 22, 2024**

Mayor Hoskins led all assembled in the Pledge of Allegiance at 7:00 p.m.

ROLL CALL

Commissioners Maxham, Nero, Melin-Rogovin, Voogd and Mayor Hoskins answered the Roll Call.

APPROVAL OF THE MINUTES OF PREVIOUS MEETINGS

It was moved by Commissioner Maxham and seconded by Commissioner Melin-Rogovin that the minutes from the July 8, 2024, Regular meeting of the Council be approved.

ROLL CALL:

AYES: Commissioners Maxham, Melin-Rogovin, Voogd and Mayor Hoskins

NAYES: None

ABSTAIN: Commissioner Nero

The motion carried.

It was moved by Commissioner Maxham and seconded by Commissioner Melin-Rogovin that the minutes from the July 8, 2024, Closed Session meeting of the Council be approved.

ROLL CALL:

AYES: Commissioners Maxham, Melin-Rogovin, Voogd and Mayor Hoskins

NAYES: None

ABSTAIN: Commissioner Nero

The motion carried.

It was moved by Commissioner Maxham and seconded by Commissioner Melin-Rogovin that the minutes from the July 11, 2024, Special meeting of the Council be approved.

It was moved by Commissioner Voogd and seconded by Commissioner Melin-Rogovin to amend the proposed minutes by adding "The Comprehensive Plan will likely go out to bid." In the Public Health and Safety Section.

ROLL CALL:

AYES: Commissioners Maxham, Nero, Melin-Rogovin, Voogd and Mayor Hoskins

NAYES: None

ABSENT: None

The motion carried unanimously.

The clerk was instructed to call the roll call on the approval of the minutes from the July 11, 2024, Special meeting of the Council, as amended.

ROLL CALL:

AYES: Commissioners Maxham, Melin-Rogovin, Voogd and Mayor Hoskins

NAYES: None

ABSTAIN: Commissioner Nero

The motion carried.

PUBLIC COMMENT

None

COMMUNICATIONS:

None

DEPARTMENT REPORTS:

None

APPROVAL OF BILLS:

It was moved by Commissioner Maxham and seconded by Commissioner Nero that the Resolution for the payment of bills be adopted. The bills totaled \$564,603.75.

**R-61-24
APPROVAL OF BILLS IN
THE AMOUNT OF
\$564,603.75
APPROVED**

ROLL CALL:

AYES: Commissioners Maxham, Nero, Melin-Rogovin,
Voogd and Mayor Hoskins

NAYES: None

ABSENT: None

The motion carried unanimously.

UNFINISHED BUSINESS:

None

NEW BUSINESS:

It was moved by Commissioner Maxham and seconded by Commissioner Nero that the Annual Appropriation Ordinance of the Village of Forest Park, Cook County, Illinois for the fiscal year beginning May 1, 2024 and ending April 30, 2025, be adopted.

**O-23-24
ANNUAL APPROPRIATION
ORDINANCE
APPROVED**

ROLL CALL:

AYES: Commissioners Maxham, Nero, Melin-Rogovin,
Voogd and Mayor Hoskins

NAYES: None

ABSENT: None

The motion carried unanimously.

It was moved by Commissioner Melin-Rogovin and seconded by Commissioner Voogd that the Resolution authorizing the contract award for the 2024 Sidewalk Program to Nardulli Construction Company, Inc. be adopted.

**R-62-24
RESOLUTION AWARDED
2024 SIDEWALK PROGRAM
TO NARDULLI
CONSTRUCTION
APPROVED**

ROLL CALL:

AYES: Commissioners Maxham, Nero, Melin-Rogovin,
Voogd and Mayor Hoskins

NAYES: None

ABSENT: None

The motion carried unanimously.

It was moved by Commissioner Melin-Rogovin and seconded by Commissioner Voogd that the Resolution to approve and authorize the execution of a Professional Engineering Services Proposal for construction engineering services for the Roosevelt Road Islands Landscaping Removal and Replacement Project by and between Christopher B. Burke Engineering, Ltd. and the Village of Forest Park be adopted.

**R-63-24
RESOLUTION APPROVING
ENGINEERING
AGREEMENT FOR
ROOSEVELT ROAD
ISLANDS REMOVAL
PROJECT
APPROVED**

ROLL CALL:

AYES: Commissioners Maxham, Nero, Melin-Rogovin,
Voogd and Mayor Hoskins

NAYES: None

ABSENT: None

The motion carried unanimously.

It was moved by Commissioner Melin-Rogovin and seconded by Commissioner Voogd that the Resolution authorizing the contract award for the Roosevelt Road Islands Landscaping Removal Project to Triggs Construction, Inc. be adopted.

**R-64-24
RESOLUTION AWARDED
ROOSEVELT ROAD
ISLAND REMOVAL
PROJECT TO TRIGGI
CONSTRUCTION, INC.
APPROVED**

ROLL CALL:

AYES: Commissioners Maxham, Nero, Melin-Rogovin,
Voogd and Mayor Hoskins

NAYES: None

ABSENT: None

The motion carried unanimously.

It was moved by Commissioner Melin-Rogovin and seconded by Commissioner Voogd that the Resolution authorizing the execution of Pay Request #10 (FINAL) for the 2023 Water Main Project to Uno Construction Co., Inc. (Wilcox & Ferdinand) be adopted.

**R-65-24
RESOLUTION
AUTHORIZING PAY
REQUEST FOR 2023
WATER MAIN PROJECT
APPROVED**

ROLL CALL:

AYES: Commissioners Maxham, Nero, Melin-Rogovin,
Voogd and Mayor Hoskins

NAYES: None

ABSENT: None

The motion carried unanimously.

ADMINISTRATOR’S REPORT:

Administrator Entler expressed her gratitude to the Police, Fire and Public Works departments for their efforts cleaning up after the storms last Sunday and Monday, as well as for setting up the Groovin’ in the Grove in the midst of that clean up. The administrator further thanked Police Department staff for their handling of the outage due to the CrowdStrike issues which put our dispatch systems on backup.

COMMISSIONER’S REPORTS:

Commissioner Maxham thanked Community Center Director, Karen Dylewski and her staff for holding the Groovin’ in the Grove event last week. It was well attended. The commissioner reported that she is volunteering for Soup and Bread and the last event benefitted Sarah’s Inn in Forest Park. Commissioner Maxham thanked the Firefighters on duty for stopping by and especially Lindsay Hankus for providing salad. The Garden Walk was hosted by the Historical Society this last weekend, thanks to chair, Kristen Lyons. Thanks were offered to Commissioner Melin-Rogovin for hosting a fundraiser for the Community Center. The Park District 16” No Gloves Tournament is this week and they need volunteers. Last, the commissioner congratulated Tim Gillian and Kristen Lyons as they were sworn in as the President and Vice President of the Park District Board.

Commissioner Nero reported the following:

- Starbucks has been under construction for the last month. They’ve invested about \$370,000 in the store, which will re-open on Wednesday.
- 7406 Madison Street has been purchased and will soon be opening a Butcher Shop
- Aldi on Harlem is under construction but has experienced some unexpected delays. Their November opening will likely be delayed.

- The Parkway Dispensary on Madison has passed their final inspections and they are currently advertising locally to hire employees for this location. Their opening date has not yet been announced.
- Casa Humilde is planning to open to the public the first week of August

Commissioner Melin-Rogovin commented on all the events happening this summer in Forest Park. There was a Bike Safety Carnival over the last weekend, which was popular. About 50 families attended the event, which had an obstacle course, safety training and distributed about 30 bike helmets. The commissioner thanked the businesses and staff who contributed as well as the contributions by the Library Staff and the Environmental Control Commission members.

Commissioner Voogd thanked the Public Works, Fire Department and Police Department staff for their efforts dealing with a lot of storm damage very quickly. The commissioner further reported that some members of the Recreation Board have moved, creating vacancies in the Board. Commissioner Voogd encouraged residents to contact her or the village website for information on how to volunteer.

ADJOURNMENT

There being no further business to be addressed, Commissioner Nero moved, and Commissioner Maxham seconded to adjourn. The motion carried unanimously.

Mayor Hoskins declared the meeting adjourned at 7:20 P.M.

Respectfully submitted,

Vanessa Belmonte, Village Clerk

**FOREST PARK
FIRE DEPARTMENT**



JUNE 2024

Fire Incident Data - June

Forest Park Fire

Count of Total Incidents & Exposures

Count of Incidents
390
Count of Exposures **390**

Aid Given/Received

Aid Given
43

EMS/Fire Incident Breakdown

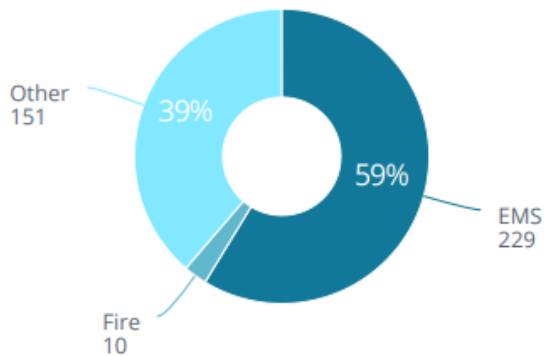

Count of Incidents by Incident Type

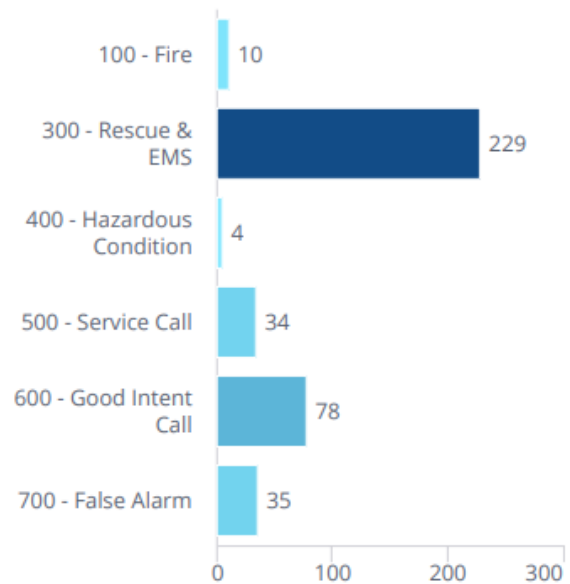

42%

FIRE
Percentage of Total Incidents

58%

EMS
Percentage of Total Incidents

390

INCIDENTS
In Selected Time Slice

30

DAYS
In Selected Time Slice

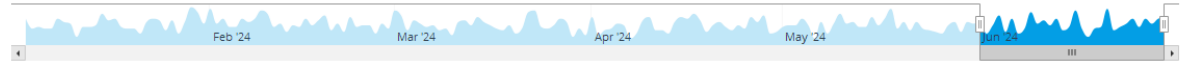
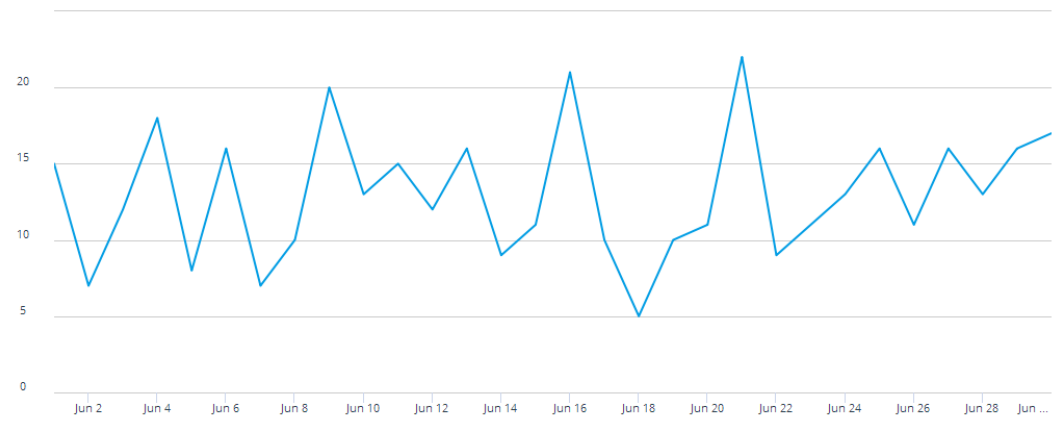

Calls for service:

The Fire Department responded to 390 calls in the month of June. That is an average of 13 calls per day for the month. 58% of the calls were for EMS. 42% were for fire/service calls.

Incidents:

06/16/2024

11 N. Harlem - Oak Park-Structure fire



Crews assisted with a Natural gas fire at the meter outside Wendys.



Fire Inspections:



Inspections:

Residential inspections: 0

Commercial inspections: 4

Re-inspections:

Commercial: 0

Residential: 0

Training

June 2024

FPFD

- | | |
|------------------------|-------|
| • Driver | 5.75 |
| • Hoseline Advancement | 3.75 |
| • Hose Testing | 22.25 |
| • Tools and Equipment | 3.75 |

Total = 35.5

Outside Drills/Classes

Total = 0

Other Activities

- | | |
|--------------------------|----|
| ○ Meeting | 8 |
| ○ Data Base | 17 |
| ○ Seminars | 0 |
| ○ Scheduling | 5 |
| ○ General Administration | 20 |

Total = 50

News and Events:

- The Fire Dept. set up the truck and flag for the Wounded Warrior ride.
- Engine 401 attended 2 block parties.
- The FD installed 1 car seat for the month of June.

RESOLUTION No.

BE IT RESOLVED by the Council of the Village of Forest Park, Cook County, Illinois, that we dispense with the reading of the individual bills inasmuch as each department head has approved and signed bills in the following aggregate amount for their respective departments.

Refunds and Allocations	527.20
Public Affairs	20,126.36
Police Department	5,561.46
Community Center	6,556.00
Accounts & Finance (Clerks Office)	186,628.69
Accounts & Finance (Fire Department)	2,912.14
Department of Health & Safety	43,606.10
Streets and Public Improvements	84,611.53
Public Property	84,803.47
Seizure	5,672.48
Federal Customs	3,341.61
TIF	8,013.29
VIP	247,704.95
Water Department	252,088.38
TOTAL	\$ 952,153.66

ADOPTED BY THE Council of the Village of Forest Park this 12th Day of August 2024

Ayes:
Nays:
Absent:

Rory Hoskins, Mayor

ATTEST:

Vanessa Moritz, Village Clerk



Account Number	Vendor	Invoice Date	Amount
100-00-000-4230-135	Dorothy Gillian	07/01/2024	200.00
100-00-000-4230-135	Tiffany Washington Randy McKnight	06/27/2024	300.00
100-00-000-4450-121	Michele Lazzara	07/25/2024	5.20
100-00-000-4450-121	Terry Burns	07/22/2024	22.00
		Refunds and Allocations	527.20



Account Number	Vendor	Invoice Date	Amount
100-10-101-6100-100	Storino Ramello & Durkin	06/30/2024	3,438.75
100-10-101-6100-100	Storino Ramello & Durkin	06/30/2024	105.00
100-10-101-6100-100	Storino Ramello & Durkin	06/30/2024	909.30
100-10-101-6120-121	AA Rental Center	06/14/2024	616.00
100-10-101-6120-150	Erich Krumrei	07/10/2024	663.98
100-10-101-6120-150	Forest Park Arts Alliance	07/19/2024	4,139.51
100-10-101-6120-150	Lakeshore Recycling Systems LLC	07/25/2024	300.00
100-10-101-6120-160	Special T Unlimited	07/19/2024	256.50
100-10-101-6120-160	Williamson Law Book Co.	07/10/2024	331.83
100-10-101-6120-300	Special T Unlimited	07/19/2024	266.00
100-10-101-6120-305	West Central Municipal Conf	07/16/2024	175.00
100-10-101-6120-305	Growing Community Media NFP	07/24/2024	275.00
100-10-101-6120-305	Westgate Flower and Plant Shop	07/11/2024	112.98
100-10-101-6150-152	Verizon Wireless	07/22/2024	42.31
100-10-101-6150-152	Verizon Wireless	07/22/2024	258.86
100-10-101-6150-202	C.O.P.S. and F.I.R.E Personnel Testing	07/16/2024	500.00
100-10-101-6150-202	C.O.P.S. and F.I.R.E Personnel Testing	07/16/2024	500.00
100-10-101-6150-202	C.O.P.S. and F.I.R.E Personnel Testing	07/16/2024	175.00
100-10-101-6150-202	C.O.P.S. and F.I.R.E Personnel Testing	07/16/2024	175.00
100-10-101-6150-202	C.O.P.S. and F.I.R.E Personnel Testing	07/16/2024	175.00
100-10-101-6150-202	C.O.P.S. and F.I.R.E Personnel Testing	07/16/2024	500.00
100-10-101-6150-202	C.O.P.S. and F.I.R.E Personnel Testing	07/16/2024	175.00
100-10-101-6150-202	C.O.P.S. and F.I.R.E Personnel Testing	07/16/2024	500.00
100-10-101-6150-202	Stanard & Associates Inc	05/14/2024	4,800.76
100-10-101-7000-150	Telcom Innovations Group LLC	07/09/2024	145.00
100-11-111-6110-110	Springbrook Holding Company LLC	07/17/2024	120.00
100-11-111-6110-110	Techno Consulting Inc	07/22/2024	469.58
		Public Affairs	20,126.36



Account Number	Vendor	Invoice Date	Amount
100-12-121-6120-305	Tom McNamara	07/24/2024	154.00
100-12-121-6145-306	Animal Care League	07/01/2024	900.00
100-12-121-6145-306	Animal Care League	07/14/2024	930.00
100-12-121-6145-306	Animal Care League	07/14/2024	300.00
100-12-121-6145-306	Animal Care League	07/14/2024	930.00
100-12-121-6145-306	Animal Care League	07/14/2024	300.00
100-12-123-6145-202	Dan Miller	01/23/2024	837.74
100-12-124-6150-114	Thomson Reuters-West	07/01/2024	468.43
100-12-126-6140-112	Informatics Holdings Inc	07/16/2024	741.29
		Police Department	5,561.46



Account Number	Vendor	Invoice Date	Amount
100-15-153-6170-202	Lakeview Bus Lines Inc	06/10/2024	840.00
100-15-153-6170-202	Lakeview Bus Lines Inc	06/17/2024	840.00
100-15-153-6170-202	Lakeview Bus Lines Inc	06/24/2024	840.00
100-15-153-6170-202	Lakeview Bus Lines Inc	07/01/2024	444.00
100-15-153-6170-202	Lakeview Bus Lines Inc	07/08/2024	888.00
100-15-153-6170-202	Lakeview Bus Lines Inc	07/16/2024	888.00
100-15-153-6170-202	Lakeview Bus Lines Inc	07/22/2024	888.00
100-15-153-6170-202	Park District of Forest Park	06/25/2024	64.00
100-15-153-6170-202	Park District of Forest Park	06/27/2024	104.00
100-15-153-6170-202	Park District of Forest Park	06/27/2024	48.00
100-15-153-6170-202	Park District of Forest Park	07/02/2024	88.00
100-15-153-6170-202	Park District of Forest Park	07/10/2024	64.00
100-15-153-6170-202	Park District of Forest Park	07/11/2024	112.00
100-15-153-6170-202	Park District of Forest Park	07/17/2024	88.00
100-15-153-6170-202	Park District of Forest Park	07/18/2024	64.00
100-15-153-6170-202	Park District of Forest Park	07/23/2024	72.00
100-15-153-6170-202	Park District of Forest Park	07/24/2024	64.00
100-15-153-6170-202	Park District of Forest Park	07/25/2024	40.00
100-15-154-6170-114	BLUE CAB CO.	07/03/2024	120.00
	Community Center		6,556.00



Account Number	Vendor	Invoice Date	Amount
100-21-211-5005-002	Blue Cross-Blue Shield of Ill	07/17/2024	147,320.29
100-21-211-5005-002	Fidelity Security Life Ins Co	07/22/2024	647.32
100-21-211-5005-002	Fidelity Security Life Ins Co	07/22/2024	75.90
100-21-211-5005-002	Guardian	07/22/2024	7,806.58
100-21-211-6100-110	Lauterbach & Amen LLP	07/18/2024	6,585.00
100-21-211-6110-110	Xerox Financial Services	07/10/2024	98.20
100-21-211-6120-300	Edward Occupational Health	06/30/2024	70.00
100-21-211-6140-104	Office 8	07/08/2024	391.92
100-21-211-6140-104	Quill	07/03/2024	58.15
100-21-211-6140-104	Quill	07/10/2024	76.02
100-21-211-6140-104	Quill	07/17/2024	115.90
100-21-211-6140-104	Quill	07/17/2024	171.80
100-21-211-6140-104	Quill	07/17/2024	227.99
100-21-211-6140-104	Quill	07/17/2024	184.73
100-21-211-6140-104	Quill	07/26/2024	43.74
100-21-211-6140-204	Jackson-Hirsh Inc	04/29/2024	383.11
100-21-211-6150-100	Growing Community Media NFP	07/10/2024	98.00
100-21-211-6150-112	Municipal Clerks North & Northwest Suburbs	07/25/2024	20.00
100-21-211-6150-112	Municipal Clerks North & Northwest Suburbs	07/25/2024	20.00
100-21-211-6150-112	Municipal Clerks North & Northwest Suburbs	07/25/2024	20.00
100-21-211-6150-116	Growing Community Media NFP	06/28/2024	105.00
100-21-211-6150-116	Growing Community Media NFP	07/10/2024	140.00
100-21-211-6150-150	AT&T	07/25/2024	122.85
100-21-211-6150-150	AT&T	07/25/2024	61.42
100-21-211-6150-150	AT&T	07/25/2024	51.95
100-21-211-6160-001	CNA Surety Direct Bill	07/16/2024	30.00
100-21-211-6160-001	Secretary of State Index Dept	07/16/2024	15.00
100-21-211-6160-001	Secretary of State Index Dept	07/16/2024	15.00
100-21-211-6190-003	POLICE PENSION FUND	07/29/2024	9,947.00
100-21-211-6190-004	Firefighters Pension Fund	07/29/2024	9,947.00
100-21-211-7000-080	GFC Leasing - WI	07/17/2024	94.61
100-21-211-7000-080	Xerox Financial Services	07/10/2024	1,684.21

Accounts and Finance (Clerks Office) 186,628.69



Account Number	Vendor	Invoice Date	Amount
100-30-302-6110-150	Verizon Wireless	07/22/2024	169.24
100-30-302-6110-200	Air One Equipment Inc	07/17/2024	165.00
100-30-302-6110-200	Municipal Emergency Services Inc	07/15/2024	1,967.29
100-30-302-6145-105	William Toth	07/25/2024	100.00
100-30-302-6150-122	Adrian Bala	07/09/2024	41.20
100-30-302-6150-122	Aaron Hannan	07/11/2024	41.20
100-30-303-6145-300	Mckesson Medical	07/20/2024	347.58
100-30-303-6145-300	Witmer Public Safety Group	07/18/2024	80.63
	Accounts and Finance (Fire Department)		2,912.14



Account Number	Vendor	Invoice Date	Amount
100-40-401-5000-017	B&F Construction Code Service	07/16/2024	160.00
100-40-401-5000-017	Raymond Traynor	07/22/2024	540.00
100-40-402-6100-100	Storino Ramello & Durkin	06/30/2024	157.50
100-40-402-6141-002	Clas Clerking	07/03/2024	202.00
100-40-402-6141-003	Christopher Burke Engineering LTD	07/10/2024	58.75
100-40-402-6141-003	Christopher Burke Engineering LTD	07/10/2024	1,832.50
100-40-402-6141-003	Christopher Burke Engineering LTD	07/10/2024	2,663.75
100-40-402-6141-003	Christopher Burke Engineering LTD	07/10/2024	235.00
100-40-402-6141-003	Christopher Burke Engineering LTD	07/10/2024	520.00
100-40-402-6141-003	Christopher Burke Engineering LTD	07/10/2024	235.00
100-40-402-6150-232	B&F Construction Code Service	06/17/2024	300.00
100-40-402-6150-232	B&F Construction Code Service	07/09/2024	160.00
100-40-402-6150-232	B&F Construction Code Service	07/09/2024	34,917.40
100-40-402-6150-240	Book Reporting Service	07/29/2024	424.20
100-40-403-6140-206	Smithereen Pest Mgmt Services	08/01/2024	1,200.00
	Department of Health and Safety		43,606.10



Account Number	Vendor	Invoice Date	Amount
100-50-501-6145-100	Special T Unlimited	07/15/2024	349.00
100-50-502-6185-108	JC Licht LLC	07/08/2024	209.91
100-50-502-6185-108	JC Licht LLC	07/19/2024	387.12
100-50-502-6185-108	JC Licht LLC	07/22/2024	419.82
100-50-502-6185-110	Forest Printing Company	07/25/2024	349.50
100-50-502-6185-112	Republic Services #551	07/15/2024	1,248.00
100-50-502-6185-501	Republic Services #551	07/15/2024	45,198.49
100-50-502-6185-502	Republic Services #551	07/15/2024	31,955.54
100-50-502-6185-503	Republic Services #551	07/15/2024	4,494.15
	Streets and Public Improvements		84,611.53



Account Number	Vendor	Invoice Date	Amount
100-55-552-6145-100	Special T Unlimited	07/15/2024	349.00
100-55-552-6180-101	RUSSO POWER EQUIPMENT	04/04/2024	243.28
100-55-552-6180-114	First Ayd Corp.	07/03/2024	639.76
100-55-552-6180-114	First Ayd Corp.	07/08/2024	375.51
100-55-552-6180-114	HOME DEPOT CREDIT	06/18/2024	19.96
100-55-553-6180-150	Lyons Pinner Electric Co	07/16/2024	24,986.00
100-55-553-6180-160	Com Ed	07/02/2024	32.50
100-55-553-6180-160	Com Ed	07/17/2024	74.00
100-55-553-6180-160	Com Ed	07/31/2024	203.43
100-55-553-6180-160	Com Ed	08/01/2024	33.63
100-55-555-6180-100	Comcast	07/08/2024	200.00
100-55-555-6180-100	A Core Locksmiths	07/23/2024	1,027.50
100-55-555-6180-100	Quill	07/03/2024	277.23
100-55-555-6180-100	Quill	07/10/2024	88.54
100-55-555-6180-100	Quill	07/17/2024	287.60
100-55-555-6180-100	PremiStar-North	07/30/2024	516.00
100-55-555-6180-110	Comcast	07/12/2024	2.10
100-55-555-6180-120	C.G.Professional Services Inc	05/03/2024	694.59
100-55-555-6180-120	Standard Industrial & Auto Eq	07/15/2024	647.44
100-55-555-6180-140	Comcast	07/07/2024	2.10
100-55-555-6180-140	Jack's Rental Inc.	07/12/2024	219.90
100-55-560-6180-125	JC Licht LLC	07/23/2024	419.82
100-55-570-6155-101	Mohr Oil Company	07/10/2024	13,979.71
100-55-570-6155-101	Mohr Oil Company	07/22/2024	14,135.29
100-55-570-6155-106	Arlington Power Equipment Inc	05/20/2024	42.16
100-55-570-6155-106	Arlington Power Equipment Inc	05/21/2024	65.38
100-55-570-6155-106	Arlington Power Equipment Inc	06/05/2024	78.00
100-55-570-6155-106	Currie Motors Chevrolet	07/16/2024	45.99
100-55-570-6155-106	Currie Motors Chevrolet	07/25/2024	96.41
100-55-570-6155-106	Currie Motors Chevrolet	07/26/2024	70.18
100-55-570-6155-106	Fleet Safety Supply	04/01/2024	69.89
100-55-570-6155-106	Fleet Safety Supply	04/09/2024	88.40
100-55-570-6155-106	Factory Motor Parts Co	06/12/2024	128.82
100-55-570-6155-106	Factory Motor Parts Co	07/11/2024	289.65
100-55-570-6155-106	Factory Motor Parts Co	07/16/2024	13.48
100-55-570-6155-106	Factory Motor Parts Co	07/16/2024	13.48
100-55-570-6155-106	Factory Motor Parts Co	07/18/2024	11.98



Account Number	Vendor	Invoice Date	Amount
100-55-570-6155-106	Factory Motor Parts Co	07/18/2024	62.89
100-55-570-6155-106	Factory Motor Parts Co	07/23/2024	41.50
100-55-570-6155-106	Factory Motor Parts Co	07/24/2024	83.44
100-55-570-6155-106	Factory Motor Parts Co	07/25/2024	287.44
100-55-570-6155-106	Kimball Midwest	07/17/2024	294.60
100-55-570-6155-106	Kimball Midwest	07/17/2024	417.06
100-55-570-6155-106	Linde Gas North America LLC	07/22/2024	230.43
100-55-570-6155-106	Linde Gas North America LLC	07/23/2024	230.45
100-55-570-6155-106	Napco Steel Inc	07/19/2024	794.00
100-55-570-6155-106	Standard Equipment Co.	02/28/2024	329.37
100-55-570-6155-106	Standard Equipment Co.	02/28/2024	905.88
100-55-570-6155-106	Standard Equipment Co.	07/08/2024	38.64
100-55-570-6155-106	Standard Equipment Co.	07/08/2024	349.42
100-55-570-6155-106	Standard Equipment Co.	07/23/2024	423.64
100-55-570-6155-106	Terminal Supply Co	07/17/2024	547.80
100-55-570-6155-106	Zeigler Ford North Riverside	07/10/2024	30.62
100-55-570-6155-106	Zeigler Ford North Riverside	07/11/2024	1,136.08
100-55-570-6155-106	Zeigler Ford North Riverside	07/12/2024	267.46
100-55-570-6155-106	Zeigler Ford North Riverside	07/16/2024	111.46
100-55-570-6155-106	Zeigler Ford North Riverside	07/18/2024	243.79
100-55-570-6155-110	Snap on Industrial	07/15/2024	23.45
100-55-570-6155-112	Commercial Tire Service	07/12/2024	238.64
100-55-570-6155-112	Commercial Tire Service	07/12/2024	271.05
100-55-570-6155-112	Commercial Tire Service	07/12/2024	271.05
100-55-570-6155-112	Fire Service Inc	06/14/2024	7,557.60
100-55-570-6155-112	Fire Service Inc	07/22/2024	78.00
100-55-580-6155-120	Jack's Rental Inc.	07/22/2024	104.00
100-55-580-6180-210	JKS VENTURES INC	07/22/2024	110.00
100-55-580-6180-302	Davis Tree Care	07/01/2024	2,800.00
100-55-580-6180-302	Davis Tree Care	07/16/2024	1,855.00
100-55-580-6180-302	Davis Tree Care	07/20/2024	950.00
100-55-580-6180-302	Davis Tree Care	07/24/2024	2,900.00
100-55-580-6180-302	Davis Tree Care	07/29/2024	350.00
		Public Property	84,803.47



Account Number	Vendor	Invoice Date	Amount
230-00-000-6150-152	Verizon Wireless	07/22/2024	250.78
230-00-000-6150-152	Verizon Wireless	07/22/2024	(12.00)
230-00-000-6900-230	Fleet Safety Supply	03/29/2024	587.44
230-00-000-6900-230	Fleet Safety Supply	04/03/2024	445.26
230-00-000-6900-230	Illinois State Police	06/27/2024	3,864.00
230-00-000-6900-230	Lamarc Jackson	08/12/2024	180.00
230-00-000-6900-230	Daniel Pater	04/25/2024	104.00
230-00-000-6900-230	Daniel Pater	07/20/2024	102.00
230-00-000-6900-230	Secretary of State	07/10/2024	151.00
		Seizure	5,672.48



Account Number	Vendor	Invoice Date	Amount
232-00-000-6900-231	C.G.Professional Services Inc	05/03/2024	1,175.97
232-00-000-6900-231	C.G.Professional Services Inc	05/03/2024	187.50
232-00-000-6900-231	Motorola Solutions StarCom21 Network	07/01/2024	120.00
232-00-000-6900-231	North East Multi-Reg Training	07/03/2024	80.00
232-00-000-6900-231	North East Multi-Reg Training	07/03/2024	80.00
232-00-000-6900-231	Ray O'Herron Co Inc	07/03/2024	235.40
232-00-000-6900-231	Ray O'Herron Co Inc	07/03/2024	38.38
232-00-000-6900-231	Ray O'Herron Co Inc	07/12/2024	73.94
232-00-000-6900-231	A Core Locksmiths	07/23/2024	1,027.50
232-00-000-6900-231	Quill	07/03/2024	322.92
		Federal Customs	3,341.61



Account Number	Vendor	Invoice Date	Amount
302-00-000-6100-100	Storino Ramello & Durkin	06/30/2024	210.00
302-00-000-6100-100	Storino Ramello & Durkin	06/30/2024	577.50
302-00-000-6100-100	Storino Ramello & Durkin	06/30/2024	105.00
302-00-000-6100-115	Lauterbach & Amen LLP	07/18/2024	343.13
304-00-000-6100-100	Storino Ramello & Durkin	06/30/2024	315.00
304-00-000-6100-100	Storino Ramello & Durkin	06/30/2024	577.50
304-00-000-6100-115	Christopher Burke Engineering LTD	07/10/2024	930.00
304-00-000-6100-115	Lauterbach & Amen LLP	07/18/2024	343.12
304-00-000-6185-700	Christopher Burke Engineering LTD	07/10/2024	3,413.00
304-00-000-6185-700	HOME DEPOT CREDIT	06/13/2024	18.85
306-00-000-6100-100	Storino Ramello & Durkin	06/30/2024	52.50
306-00-000-6100-115	Lauterbach & Amen LLP	07/18/2024	343.13
309-00-000-6100-100	Storino Ramello & Durkin	06/30/2024	441.44
309-00-000-6100-115	Lauterbach & Amen LLP	07/18/2024	343.12
		TIF	8,013.29



Account Number	Vendor	Invoice Date	Amount
312-00-000-6100-100	Storino Ramello & Durkin	06/30/2024	262.50
312-00-000-6100-105	Christopher Burke Engineering LTD	07/10/2024	1,887.50
312-00-000-6100-115	Lauterbach & Amen LLP	07/18/2024	457.50
312-00-000-6150-152	Environmental Systems Research Institute Inc	07/10/2024	1,747.50
312-00-000-6150-152	Verizon Wireless	07/22/2024	38.01
312-00-000-7000-120	Christopher Burke Engineering LTD	07/18/2024	882.73
312-00-000-7000-130	Christopher Burke Engineering LTD	07/10/2024	11,766.65
312-00-000-7000-130	J. Nardulli Concrete Inc	07/12/2024	220,346.35
312-00-000-7000-312	Christopher Burke Engineering LTD	07/10/2024	2,950.00
312-00-000-7000-312	Christopher Burke Engineering LTD	07/10/2024	2,280.09
312-00-000-7000-312	Cairo & Sons Roofing Contractors Inc.	07/17/2024	4,745.00
312-00-000-7000-312	K-Five Hodgkins LLC	06/26/2024	51.84
312-00-000-7000-312	K-Five Hodgkins LLC	07/02/2024	46.08
312-00-000-7000-312	K-Five Hodgkins LLC	07/03/2024	35.84
312-00-000-7000-312	K-Five Hodgkins LLC	07/11/2024	67.84
312-00-000-7000-312	K-Five Hodgkins LLC	07/12/2024	36.48
312-00-000-7000-312	K-Five Hodgkins LLC	07/17/2024	103.04
		VIP	247,704.95



Account Number	Vendor	Invoice Date	Amount
501-80-800-6100-100	Storino Ramello & Durkin	06/30/2024	3,333.75
501-80-800-6100-105	Christopher Burke Engineering LTD	07/10/2024	2,582.64
501-80-800-6100-110	Lauterbach & Amen LLP	07/18/2024	6,585.00
501-80-800-6110-105	Verizon Wireless	07/22/2024	36.01
501-80-800-6145-100	Special T Unlimited	07/15/2024	168.00
501-80-800-6150-150	AT&T	07/25/2024	65.40
501-80-800-6150-154	Com Ed	07/16/2024	173.27
501-80-800-6150-154	Com Ed	07/17/2024	23.17
501-80-800-6800-150	CDC ENTERPRISES INC	06/21/2024	2,496.12
501-80-800-6800-150	CDC ENTERPRISES INC	07/08/2024	7,493.79
501-80-800-6800-150	CDC ENTERPRISES INC	07/23/2024	1,833.00
501-80-800-6800-150	Elmhurst Chicago Stone Company	07/25/2024	686.00
501-80-800-6800-151	Elmhurst Chicago Stone Company	07/15/2024	36.00
501-80-800-6800-151	Elmhurst Chicago Stone Company	07/25/2024	3,189.00
501-80-800-6800-151	OTM Water Services	05/29/2024	2,150.00
501-80-800-6800-151	OTM Water Services	06/05/2024	1,100.00
501-80-800-6800-151	OTM Water Services	06/12/2024	3,550.00
501-80-800-6800-152	Joseph Danno	03/05/2024	1,487.00
501-80-800-6800-153	Comcast	07/06/2024	86.90
501-80-800-7000-003	Christopher Burke Engineering LTD	07/10/2024	23,028.62
501-80-800-7000-006	Christopher Burke Engineering LTD	07/10/2024	16,625.90
501-80-800-7000-006	Christopher Burke Engineering LTD	07/10/2024	4,975.68
501-80-800-7000-010	CDC ENTERPRISES INC	07/22/2024	28,844.00
501-80-800-7000-020	Christopher Burke Engineering LTD	07/10/2024	20,279.13
501-80-800-7000-010	J. Nardulli Concrete Inc	07/12/2024	121,260.00
		Water Department	252,088.38

AN ORDINANCE WAIVING BID AND AUTHORIZING THE PURCHASE OF A FULLY EQUIPPED 2023 FORD F350 UTILITY TRUCK WITH BUILDOUT

WHEREAS, the Village of Forest Park (the “Village”), a body politic and corporate, duly organized and existing as a municipal corporation of the State of Illinois, is authorized by the laws of the State of Illinois to purchase and acquire personal property for the benefit of the Village and its inhabitants and to enter into contracts with respect thereto; and

WHEREAS, the corporate authorities of the Village deem it for the benefit of the Village and for the efficient and effective administration thereof that the Village purchase a fully equipped 2023 Ford F350 Utility Truck with Buildout (the “Vehicle”) for the Village Public Works Department, constituting personal property necessary for the Village to perform essential governmental functions; and

WHEREAS, the Village solicited and received a proposal for the purchase of the Vehicle from Ron Tirapelli Ford (“Tirapelli Proposal”), with the attached Vehicle buildout quotes for the Vehicle’s buildout (“Buildout Proposals”); and

WHEREAS, in the opinion of four-fifths of the corporate authorities of the Village, it is advisable, necessary and in the public interest that the Village waive the purchasing procedure prescribed in the Village Code and purchase the Vehicle, pursuant to the Tirapelli Proposal and the Buildout Proposals for an approximate total cost not to exceed Eighty Thousand and 00/100 Dollars (\$80,000.00), collectively attached hereto and made a part hereof as Exhibit A (the “Proposals”).

NOW, THEREFORE, BE IT ORDAINED by the Council of the Village of Forest Park, Cook County, Illinois, as follows:

Section 1: That the facts and statements contained in the preamble to this Ordinance are found to be true and correct and are hereby adopted as part of this Ordinance.

Section 2: That it is hereby determined that it is advisable, necessary and in the public interest that the Village of Forest Park waive the purchasing procedures prescribed in the Village Code and purchase the Vehicles with buildout, pursuant to the terms and provisions of the Proposals.

Section 3: That the officers and employees of the Village shall take all action necessary or reasonably required by the parties to carry out, give effect to and consummate the transactions

contemplated hereby and to take all action necessary in conformity therewith, including, without limitation, the execution and delivery of any closing and other documents required to be delivered in connection with the Proposals.

Section 4: That if any section, paragraph, clause or provision of this Ordinance shall for any reason be held to be invalid or unenforceable, the invalidity or unenforceability of such section, paragraph, clause or provision shall not affect any of the remaining provisions of this Ordinance.

Section 5: That this Ordinance shall be in full force and effect after its passage by four-fifths of all the commissioners holding office, approval and publication in pamphlet form as provided by law.

ADOPTED by the Council of the Village of Forest Park, Cook County, Illinois this 12th day of August, 2024.

AYES: _____

NAYS: _____

ABSENT: _____

APPROVED:

Mayor Rory E. Hoskins

ATTESTED and filed in my office,
and published in pamphlet form
this _____ day of August, 2024.

Vanessa Belmonte, Village Clerk

EXHIBIT A

VEHICLE AND BUILDOUT PROPOSALS



AGENDA MEMO

Village Council Meeting

Forest Park, Illinois

August 12, 2024

Issue Statement

Request for Village Council to approve the purchase of a 2023 Ford F350 Utility Truck, including Village logo decals, Rhino lining, snow plow, power lift gate & emergency lighting for the Public Works Department.

Background

The Public Works Department has a Traffic & Sign Division. This crew has a 2006 F350 Utility Truck with a power lift gate. The truck has 90K miles. This Division takes care of all the Village owned traffic signs and the poles they are assembled to. This Division also handles all temporary signage that pertains to event staging, no parking signage and lot closure. The transportation of barricades for any events is primarily with this truck. During the Spring, Summer & Fall this truck houses the paint striper. This heavy piece of machinery is what paints all the curbs in town. It also paints the parking stall lines and symbols in the Village's Municipal parking lots. In the Winter, this truck transports the snowblowers throughout town to their needed locations. With this being a utility truck, it is the only truck, besides the Water Department truck, that houses a full variety of tools that can mobilize to a given location when needed. This truck is also used when there is a need to transport heavy items. The power lift gate comes in handy. Over the last month, we noticed that the line striper was starting to lean when it was on the truck and the crew was painting curbs. It was determined that the truck is 18 years old and that there was rust on the bed. Fleet Services ordered new steel to weld as a new bed so we could get some more years out of the truck. When George started to take the Rhino lining off the bed, it was determined that most of the bed had rusted away, along with the sidewalls and toolbox walls. The support bars holding the bed in place are also severely rusted. George deemed the truck unsafe and unable to perform its duties. It could only be used to drive.

I am asking the council to reallocate available ARPA funds that are no longer being used for initial purchases that was reported. I am then asking the council to purchase a new Ford F350 Utility Truck with those reallocated ARPA funds. The price of the Ford F350 Utility Truck is

\$57,050.00. Outfitting the truck with emergency lights will be approximately \$2K – \$3K. Rhino lining will be approximately \$1K. The Tommy Lift automatic lift gate will be approximately \$3K - \$5K. Village logo decals will be \$500 - \$1K. Snow Plow assembly will be \$8K. This truck will be between **\$75K - \$80K** fully outfitted. Putting this truck back into the fleet at Public Works will allow the Traffic & Sign Division to function accurately and efficiently. Having a vehicle with mobile tools and a vehicle able to transport the line striper is crucial to the Public Works Department. It will also ensure that the Public Works crew will be able to operate in a safe manner by allowing the automatic lift gate to do any heavy lifting for them when transporting heavy items.

Attachments

- 2023 Ford F350 Quote
- 2023 Ford F350 Window Sticker
- Plow & Lift gate Quote
- Reading Utility Body Brochure
- Tommy Lift G2 Brochure
- Illustrations Of Current Vehicle

A handwritten signature in black ink that reads "Sal Stella". The signature is written in a cursive style with a long horizontal stroke at the end.

Sal Stella
Director of Public Works



ford.com

VEHICLE DESCRIPTION

SUPER DUTY

2023 F350 SRW 4X4 REG CAB
XL 142" WB STYLESIDE
6.8L DEVCT NA PFI V8 ENGINE
10-SPEED AUTO TORQSHIFT-G

PE D54303

EXTERIOR OXFORD WHITE
INTERIOR MEDIUM DARK SLATE VINYL

STANDARD EQUIPMENT INCLUDED AT NO EXTRA CHARGE

EXTERIOR

- BOX RAIL/TAILGATE MOLDINGS
- DOOR HANDLES - BLACK
- HEADLAMPS - AUTOLAMP (ON/OFF)
- PICKUP BOX TIE DOWN HOOKS
- POWER TAILGATE LOCK
- TOW HOOKS
- TRAILER BRAKE CONTROLLER
- TRAILER SWAY CONTROL
- WIPERS- INTERMITTENT

INTERIOR

- 4.2" PRODUCTIVITY SCREEN
- AIR COND, MANUAL FRONT
- CLOTH SUN VISORS
- DRIVER SEAT-MANUAL LUMBAR
- OUTSIDE TEMP DISPLAY
- PARTICULATE AIR FILTER
- POWER LOCKS AND WINDOWS
- STEERING:TILT/TELESCOPE, CRUISE & AUDIO CONTROLS

FUNCTIONAL

- 4-WHEEL ANTILOCK BRAKE SYS
- FORDPASS™ CONNECT 5GWI-FI HOTSPOT TELEMATICS MODEM
- HILL START ASSIST
- MANUAL LOCKING HUBS
- MONO BEAM COIL SPRING FRT SUSPENSION W/STAB BAR
- REAR VIEW CAMERA
- REMOTE KEYLESS ENTRY
- SYNC®4 W/8" SCREEN

SAFETY/SECURITY

- ADVANCETRAC™ WITH RSC®
- AIRBAGS - SAFETY CANOPY®
- BELT-MINDER CHIME
- DRIVER/PASSENGER AIR BAGS
- SECURILOCK® ANTI-THEFT SYS
- SOS POST-CRASH ALERT SYS™

WARRANTY

- 3YR/36,000 BUMPER / BUMPER
- 5YR/60,000 POWERTRAIN
- 5YR/60,000 ROADSIDE ASSIST
- 5YR/100,000 DIESEL ENGINE

INCLUDED ON THIS VEHICLE

OPTIONAL EQUIPMENT/OTHER

- PREFERRED EQUIPMENT PKG.610A
- 10-SPEED AUTO TORQSHIFT-G
- LT275/70R18E BSW ALL TERRAIN
- 3.73 ELECTRONIC-LOCKING AXLE
- FRONT LICENSE PLATE BRACKET
- PLATFORM RUNNING BOARDS
- 11400# GVWR PACKAGE
- 50 STATE EMISSIONS
- 120V/400W OUTLET
- SNOW PLOW PREP PACKAGE
- ROOF CLEARANCE LIGHTS
- JACK
- UPFITTER SWITCHES
- 410 AMP ALTERNATOR
- DUAL BATTERY

(MSRP)

NO CHARGE	
265.00	
430.00	
NO CHARGE	
320.00	
NO CHARGE	
175.00	
250.00	
95.00	
165.00	
115.00	
210.00	

PRICE INFORMATION

BASE PRICE	\$47,815.00
TOTAL OPTIONS/OTHER	2,025.00
TOTAL VEHICLE & OPTIONS/OTHER	49,840.00
DESTINATION & DELIVERY	1,895.00

California Air Resources Board

Gasoline Vehicle

Environmental Performance

These ratings are not directly comparable to the U.S. EPA/DOT light-duty vehicle label ratings. For information on how to compare, please see www.arb.ca.gov/ep_label.

Protect the environment. Choose vehicles with **higher ratings**:

Greenhouse Gas Rating (tailpipe only)



Smog Rating (tailpipe only)



Vehicle emissions are a primary contributor to climate change and smog. Ratings are determined by the California Air Resources Board based on this vehicle's measured emissions.



The FordPass® Connect modem is active and sending vehicle data (e.g., diagnostics) to Ford.** See in-vehicle settings for connectivity options.

*Based on 1977–2022 CY total sales.
**FordPass Connect (optional on select vehicles), the FordPass App and complimentary Connected Service are required for remote features (see FordPass Terms for details). Connected service and features depend on compatible AT&T network availability. Evolving technology/cellular networks/vehicle capability may limit functionality and prevent operation of connected features. Connected service excludes Wi-Fi hotspot.



Insist on Ford Protect! The only extended service plan fully backed by Ford and honored at every Ford dealership in the U.S., Canada and Mexico. See your Ford dealer or visit www.FordOwner.com.

1FTRF3BA7PED54303



WARNING: Operating, servicing and maintaining a passenger vehicle, pickup truck, van, or off-road vehicle can expose you to chemicals including engine exhaust, carbon monoxide, phthalates, and lead, which are known to the State of California to cause cancer and birth defects or other reproductive harm. To minimize exposure, avoid breathing exhaust, do not idle the engine except as necessary, service your vehicle in a well-ventilated area and wear gloves or wash your hands frequently when servicing your vehicle. For more information go to www.P65Warnings.ca.gov/passenger-vehicle.

SCAN QR TEXT 1FPED54303 TO 48028

Msg & Data rates may apply. Text HELP for help



www.ford.com/help/privacy-terms/

RAMP ONE	CA1K	CONVOY
RAMP TWO	ITEM #: 41-3173 O/T 59	

TOTAL MSRP \$51,735.00



Whether you decide to lease or finance your vehicle, you'll find the choices that are right for you. See your dealer for details or visit www.ford.com/finance.

SPECIAL ORDER

R727 R 6B 2X 345 020211 07 21 23

This label is affixed pursuant to the Federal Automobile Information Disclosure Act. Gasoline, License, and Title Fees, State and Local taxes are not included. Dealer installed options or accessories are not included unless listed above.



Family owned since 1984



Purchase Agreement

Katie DeCrane
 Tirapelli Ford
 4355 W Jefferson St
 Shorewood, IL 60404

Buyer	Co-Buyer	Vehicle
Village of Forest Park George Prescott 517 Des Plaines Ave Forest Park, IL 60130 C: (708) 878-3826 gprescott@forestpark.net		2023 Ford Super Duty F-350 SRW XL VIN: 1FTRF3BA7PED54303 Stock #: 238813 Mileage: 209 Color: Oxford White

Purchase Details	
Sales Price:	\$58,984.00
Accessories:	\$0.00
Service Contract:	\$0.00
GAP:	\$0.00
Government Fees:	\$208.00
Documentation Fee:	\$358.03
Estimated Taxes:	\$0.00
Total Sales Price:	\$59,550.03
Trade Allowance:	\$0.00
Trade Payoff:	\$0.00
Trade Equity:	\$0.00
Rebate:	\$2,500.00
Cash Down:	\$0.00
Cash Price:	\$57,050.03

X

 Customer Signature

X

 Manager Signature

 Date

 Date

Disclaimer:

Printed 7/29/24 2:33 PM

With Approved Credit. Special Finance rate may be in lieu of rebates. Ask for details.



255 W. Laura Drive
Addison, IL 60101

Phone: 630.543.0330
Fax: 630.543.9806

QUOTATION

Quotation #: 84099
Date: 07/31/24
Sales Person: Jacquelyn

BILL TO:
George
Village Of Forest Park 15395
Fire Department
7625 Wilcox Street
Forest Park IL 60130
(708) 366-1234

SHIP TO:
Same

Phone

PO#:	Terms:
	NET 10

Vehicle Information:	VIN #:	Serial #:
23 FORD F-350		

FURNISH & INSTALL.

"TOMMY-GATE" SERVICE BODY LIFTGATE: G2 DUAL DRIVE SERIES
Woodbine "TOMMY-GATE" liftgate model G2-54-1342TP42. 1300# capacity,
elec/hyd operation, toggle switch control, 49" x 42" 2-piece tread-
plate steel platform with 7" tapered ramp, liftgate painted black. 4401.00
Add for LED tail Light Kit in Lieu of standard Tail light kit... 700.00

8' Pro Plow 3 steel snowplow blade
power angling Nighthawk plow lights plow guides. 6244.00
Cab-command handheld control. 570.00
Add for LED lights 391.00
Add for Rubber Deflector

*Municipal Pricing Applied

TOTAL -> 12,306.00

Located in Addison, the Northwest Suburbs of Chicago, Alsip and in the South Suburbs, Regional Truck Equipment is an authorized distributor of Western Snowplows, Salt Spreaders, and Parts, Knaphaide Bodies, Adrian Steel Products, as well as many others.

At REGIONAL TRUCK the customer comes first.

For best service call us now.
630-543-0330

New Equip. Price	
Used Equip. Price	
Parts Price	
Subtotal	.00
Trade-In	
Total Taxable	
Sales Tax (8%)	
Labor	
Delivery	
FET	
Processing Fee	
Invoice Total	.00

To accept this quotation, sign here and return: _____

Quotation valid for 30 days.

REGIONAL MAKES NO WARREAVNTY OF ANY KIND, EXPRESSED OR IMPLIED; AND DISCLAIMS ALL IMPLIED WARRANTIES OF MERCHANTABILITY AND FITNESS FOR A PARTICULAR PURPOSE. 1 1/2% Per Month (18% ANNUM) will be charged on unpaid invoices. \$25.00 charge on uncollected checks. All collection agency and legal fees are the responsibility of the customer. We reserve title to all merchandise until paid. Customer shall rely solely upon the manufacturer's warranty, if any. Any goods or property of the customer not picked up within ten days after the date shown on the invoice will incur a storage charge of \$14.00 a day. Any property not picked up within six months may be sold without notice, to satisfy storage charges.



**SERVICE
BODIES**



SL SERVICE BODY

CLASSIC II™ SERVICE BODY
STEEL | ALUMINUM

**CLASSIC II™ STEEL HEAVY-DUTY
SERVICE BODY**

MECHANIC SERVICE BODY

MADE IN THE USA



Service bodies you can count on to work at your best.

We know exactly what you need from a service body to be successful whether you need one truck or have a fleet of them.

That's why our bodies are made with time-tested, field-proven durability to tackle harsh environments and tough jobsites. They're equipped with features for working safely in all conditions. They're built with pride and craftsmanship to keep you going for the long haul.

It makes us the service body of choice for hundreds of thousands of people across the country and why companies of all sizes in so many industries turn to us to help them work better than ever. It's why our service bodies are synonymous with the highest quality materials and buying one tells the world you're a true professional.

It's why we're the only service body you'll ever need.



SL STEEL

Our SL service body offers an economical alternative that features a premium A60 galvanized steel construction with E-coat primer and powder coat finish as standard equipment. If you demand a steel service body built for the long haul, the SL delivers with heavy-duty compartment doors, stainless steel bolt-on hinges and our Dual-Pro® seal system. This is what toughness really looks like.



CLASSIC II™ STEEL

The Classic II™ steel service body is built with premium A60 coating-weight steel construction. Our exclusive E-coat primer and powder coat finish offer superior corrosion resistance and long life. Our signature pressed tread plate surface on the load floor and inner tailgate surface provide all the strength and durability you need. Our hidden hinge system is fully adjustable and theft-resistant while our premium Dual-Pro seal system offers expanded door clearances and superior weather protection.



CLASSIC II™ ALUMINUM

Our Aluminum Classic II™ service body offers weather-tight storage and customizable options with the lightweight advantages of all-aluminum construction. Aluminum resists corrosion, lets you increase available payload and much more. These bodies feature fully adjustable hidden hinges to deter break-ins. A Dual Pro seal system has unmatched weather protection with expanded door clearances. You get long-lasting toughness that saves fuel and money year after year.



CLASSIC II™ STEEL HEAVY-DUTY

When you work in contracting, utilities, HVAC or any other service industry, the trucks you use to store and transport your equipment need to be as efficient and custom upfitted as they are powerful. For upfits on a class 6/7 chassis, you'll need a heavy-duty body. So if you're searching for a service body built to withstand the most challenging tasks and perform in extreme weather conditions, you're covered. We make a full line of service bodies for customers who demand more than the typical utility body.



MECHANIC

Vocations like mobile service, oil and gas industries and heavy construction sometimes need all the toughness of a crane body, without the crane. To serve these industries, Reading offers our traditional Mechanic Service Body. With features like workbench bumpers, 60" tall compartments with drawer units, work lights, and air compressor and welders setup, the Reading Mechanic Service Body is the trusted way to build the ultimate mobile workshop.



WE'RE HERE TO HELP.

readingtruck.com



IS STEEL RIGHT FOR YOU? OR ALUMINUM? IT DEPENDS.

Choose our award-winning, lightweight aluminum body to help save fuel, save money and increase your payloads all while carrying the industry's best warranties. Or choose our A60 coating-weight galvanized steel bodies with acrylic E-coat primer and powder coat finish.

Which one works best depends on your job, industry, geography, weather conditions and your specific needs.

STEEL

Sometimes you just need the strength of steel when you are hauling heavy material or equipment in harsh environments.

The strength and resistant properties of steel make it one of the most durable industrial materials. Our premium A60 coating-weight steel and our exclusive triple protection E-coat primer and powder coat finish help to resist corrosion. A steel service body is built for a more demanding environment, like mining, oil and gas, maintenance and rail industries.

ALUMINUM

Over 40 years ago, we were the first manufacturer to produce an aluminum service body. Today, we're a premier manufacturer of aluminum truck bodies in North America.

Aluminum's lightweight properties make it easier on your truck's drive train, which could help lead to a longer life for your truck. While a service body that's lighter on the road can lead to reduced fuel costs, it also allows you to increase your payload, both of which can save you money. And, with aluminum being naturally corrosion-resistant, our E-coat primer and durable powder coat finish makes it capable of withstanding years of heavy use — all around better for the environment.

STANDARD FEATURES STEEL BODY

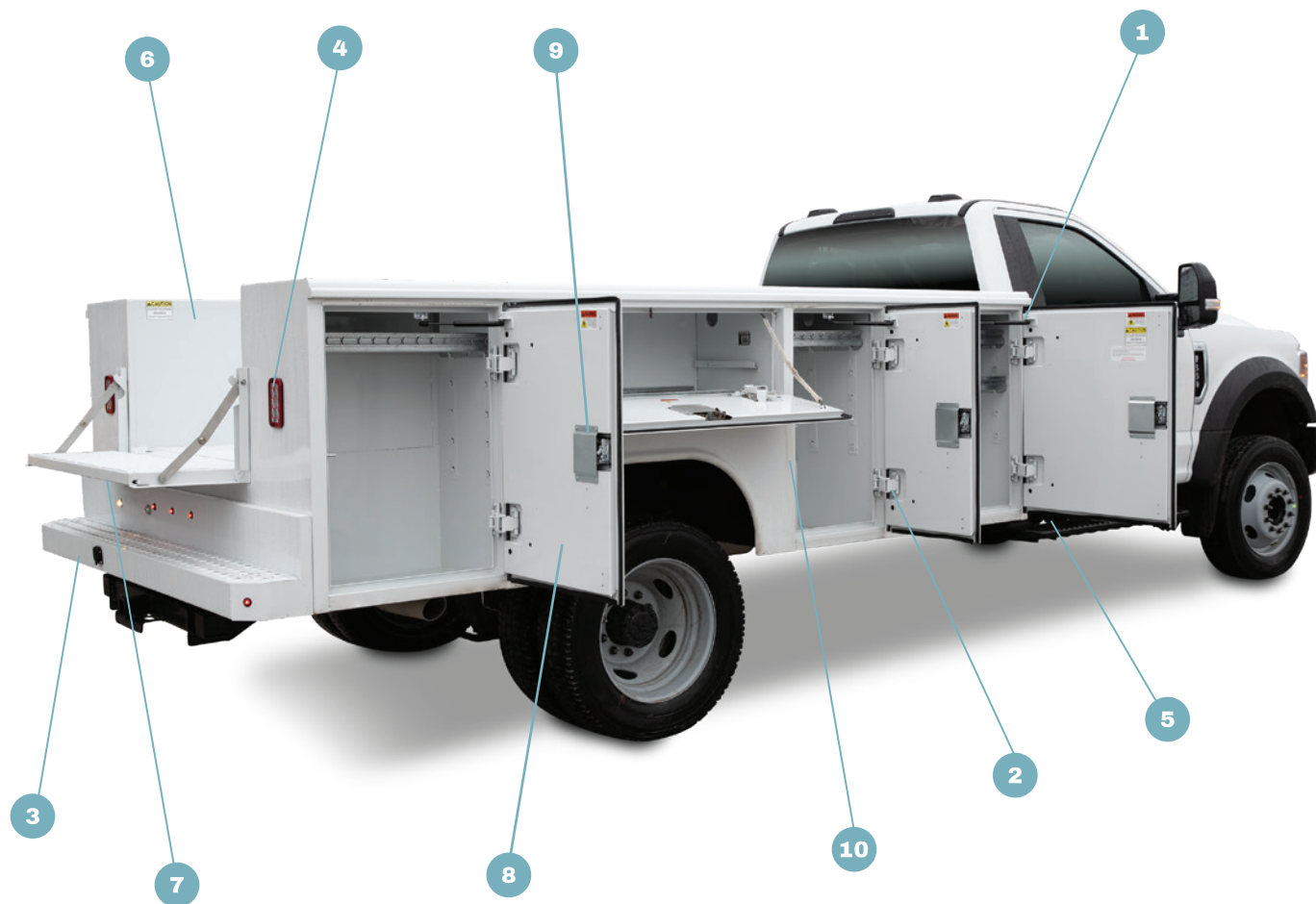

STANDARD FEATURES STEEL BODY

FEATURES APPLY TO SL, CLASSIC II AND HEAVY-DUTY STEEL SERVICE BODIES UNLESS OTHERWISE NOTED.

1 GAS STRUT DOOR HOLDERS

Nitrogen gas door struts control opening and closing of all vertical compartment doors. (Standard on Classic II only)

2 HIDDEN HINGES

Hidden hinges deter forced entry and protect against corrosion without needing frequent lubrication or maintenance. The hinges are fully adjustable and can be replaced without damaging the body or door.

3 BUMPERS

Bumpers provide improved traction and give you sure-footed access to the cargo area. Bumpers are galvanized steel for exceptional corrosion resistance and come straight or with a center recess for easy access to the trailer hitch.

4 LED LIGHTS

LED combination lights last longer, stay cooler and glow brighter. They're water-resistant with automotive-grade sealed connectors.

5 DUAL-PRO® SEAL SYSTEM

Get twice the defense against weather. Our premium Dual-Pro® door seal system combines automotive quality weatherstripping with mechanical seals. Our design increases clear door openings in every compartment.

6 E-COAT PRIMER AND POWDER COAT FINISH

Our E-coat primer and powder coat finish protect the body from corrosion, chemicals, humidity, scratches, chips and impact for longer life.

7 SLAM-ACTION TAILGATE

The pickup style slam-action tailgate features stainless steel knee braces, locking rods, hinge rods and striker channels. The knee braces are removable and protect against rust and corrosion while allowing the tailgate to swing down completely. Our 14" tailgate, equipped with treadplate, provides a larger surface area for better stability and traction.

8 HEAVY-DUTY DOORS

Heavy-duty compartment doors feature double-paneled construction with internal reinforcement and heavy gauge steel panels to handle the roughest jobsites.

9 ROTARY LOCKS AND PADDLE HANDLES

Our stainless steel rotary locks and paddle handles have a clean, smooth look that's both professional and functional. They feature a double-bitted, locking cylinder, adjustable striker pins and an O-ring seal to stop water intrusion.

10 SEAMLESS WHEELHOUSE PANELS

Seamless wheelhouse panels keep dirt, grime and moisture from collecting to minimize corrosion and extend the life of your truck.

11 GALVANIZED SHELVES

Galvanized shelves feature 2" dividers for custom and convenient small-item storage.

ALUMA-FILL® FUEL RECEPTACLE

Our Aluma-Fill® fuel receptacle protects the body and finish from accidental nicks and scratches from fuel nozzles. It is more durable than plastic brackets.

INCLUDED ONLY ON SL:

BOLT-ON HINGES

Stainless steel bolt-on hinges are protected from the elements with a fully concealed pin and marine-grade stainless steel bearings to ensure smooth, reliable operation.



SPRING-LOADED DOOR HOLDER



The spring-loaded door holder is on all vertical doors. It gives you easy access to your tools and gear by holding the door open in a 90-degree position. The hasp is removable when you need to have an extra-wide opening.

STANDARD FEATURES ALUMINUM BODY



STANDARD FEATURES ALUMINUM BODY

FEATURES APPLY TO ONLY CLASSIC II ALUMINUM SERVICE BODIES.

1 HIDDEN HINGES

Hidden hinges deter forced entry and protect against corrosion without needing frequent lubrication or maintenance. The hinges are fully adjustable and can be replaced without damaging the body or door.

2 LED LIGHTS

LED combination lights last longer, stay cooler and glow brighter. They're water-resistant with automotive-grade sealed connectors.

3 DUAL-PRO SEAL SYSTEM

Get twice the defense against weather. Our premium Dual-Pro door seal system combines automotive quality weatherstripping with mechanical seals. Our design increases clear door openings in every compartment.

4 E-COAT PRIMER AND POWDER COAT FINISH

Our E-coat primer and powder coat finish protect the body from corrosion, chemicals, humidity, scratches, chips and impact for long life.



5 SLAM-ACTION TAILGATE

The pickup style slam-action tailgate features stainless steel knee braces, locking rods, hinge rods and striker channels. The knee braces are removable and protect against rust and corrosion while allowing the tailgate to swing down completely. Our 14" tailgate, equipped with treadplate, provides a larger surface area for better stability and traction.

6 GAS STRUT DOOR HOLDERS

Nitrogen gas door struts control opening and closing of all vertical compartment doors.

7 HEAVY-DUTY DOORS

Heavy-duty compartment doors feature double-paneled construction with internal reinforcement and heavy gauge aluminum panels.

8 ROTARY LOCKS

Rust-resistant stainless steel rotary locks boast an attractive appearance with no exposed fasteners. They feature a double-bitted, high-quality locking cylinder, adjustable striker pins and an O-ring seal to prevent water intrusion.

9 SEAMLESS WHEELHOUSE PANELS

Seamless wheelhouse panels keep dirt, grime and moisture from collecting to minimize corrosion and extend the life of your truck.

10 ALUMA-FILL FUEL RECEPTACLE

Our Aluma-Fill fuel receptacle protects the body and finish from accidental nicks and scratches from fuel nozzles. It is more durable than plastic brackets.

GALVANIZED SHELVES

Galvanized shelves are designed with 2" dividers for custom and convenient small item storage. Full access between the horizontal and rear vertical makes it easy to store longer tools.



POPULAR OPTIONS

SPACEMAKER® BODY

Spacemaker® bodies offer top-opening compartments with fifteen percent more storage space. Lids are reinforced and equipped with two nitrogen gas props for easy opening and closing. Rotary catches with a push-button release allow easy one-handed closure from either end. Available in powder coated or bright aluminum treadplate.



LATCH-MATIC® SECURITY SYSTEM

Our Latch-Matic® system can be controlled with your existing OEM key fob remote and chassis power-door locks. When the Latch-Matic system is integrated into the chassis, the driver's key fob and door lock switches will lock and unlock the service body and the chassis doors. The system has proven, automotive-quality components and key fob transmitters designed for convenience that keep your tools safe and secure. Available on most Ford, RAM and GM chassis.



LED COMPARTMENT LIGHTING

Strip lighting and dome lights work together with the Latch-Matic system, activating lights when compartment doors are locked and unlocked so you and your crew can work safely and productively when daylight disappears. Programmed to shut off after ten minutes. (Classic II only)

OVERHEAD LADDER RACK

Lets you store ladders securely and out of the way on the top of your service body.

MASTER-LOCKING STEEL SLIDE BAR



Protect your valuables with the snap of a single handle and padlock. Our master-locking steel slide bar simultaneously locks an entire compartment side to keep your tools and gear secure.

SPRAY-ON BEDLINER

Get watertight and airtight bed protection. Our factory-installed bedliner resists rust, corrosion and surface abrasion while giving you a safer, slip-resistant surface.

STAINLESS STEEL T-HANDLE LOCKS

If you need a higher level of security, compartment doors can be upgraded to three-point locking with T-handles that provide extra resistance to prying and tampering.

RETRACTABLE UTILITY BED COVER (RUBC)

Our RUBC protects the cargo area from weather and keeps valuables secure. It's available as a manual spring action cover or with an electric motor operated by a manual switch or an optional hands-free remote. (Sold separately)

STEEL SLIDING TOP

Our steel sliding top is another smart way to secure items placed in the truck body center deck. It slides on full-length galvanized steel tracks for easy opening and closing while a two-point positive action stainless steel T-handle lock secures your tools and gear.



Popular options are available on all models unless otherwise noted.



82" SERVICE BODY

- The 82" service body is designed to fit on short bed pickups (40-42" CA) with Aftermarket Box Removal (AMBR) by your Reading upfitter.
- The 82" body is limited to Ford and GM chassis only.
- Available for single-wheel (SW) chassis only.
- Available in: **CLASSIC II STEEL** | **CLASSIC II ALUMINUM**

FOR 40-42" CA SHORT BED PICKUP

STANDARD 40" BODY

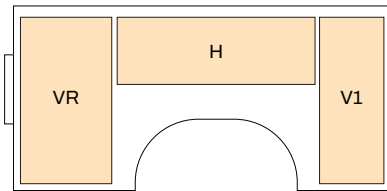

CURBSIDE VIEW

COMPARTMENT SIZES

V1	17" W x 40" H	13" D
H	42" W x 18.50" H	13" D
VR	23" W x 40" H	13" D

LENGTH 82	HEIGHT 40	WIDTH 77.5
TYP. WEIGHT	STEEL 919	ALUMINUM 472

LOW PROFILE BODY

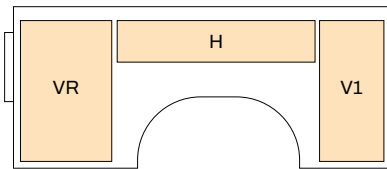

CURBSIDE VIEW

COMPARTMENT SIZES

V1	17" W x 35" H	13" D
H	42" W x 13.50" H	13" D
VR	23" W x 35" H	13" D

LENGTH 82	HEIGHT 35	WIDTH 77.5
TYP. WEIGHT	STEEL 919	ALUMINUM 472

40" BODY WITH SPACEMAKER TOP

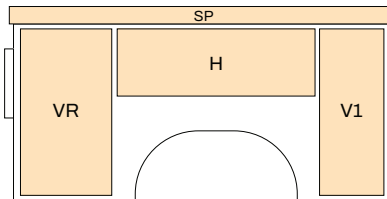

CURBSIDE VIEW

COMPARTMENT SIZES

V1	17" W x 37" H	13" D
H	42" W x 13.50" H	13" D
VR	23" W x 37" H	13" D
SP	72" W x 4.5" H	9.6" D

TYP. WEIGHT	STEEL 1,084	ALUMINUM 574
-------------	--------------------	---------------------

Spacemaker top-opening compartment provides 15% more storage space. Lid is offered in your choice of steel (powder coated) or bright aluminum finish.

B-COMPARTMENT LAYOUT

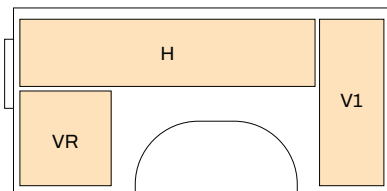

CURBSIDE VIEW

COMPARTMENT SIZES

V1	17" W x 40" H	13" D
H	65" W x 18.50" H	13" D
VR	23" W x 21.50" H	13" D

LENGTH 82	HEIGHT 40	WIDTH 77.5
TYP. WEIGHT	STEEL 969	ALUMINUM 522

Reading Truck offers B-compartment layout with an extended horizontal compartment for storing longer items.



98" SERVICE BODY

- The 98" service body is designed to fit on long bed pickups (56" CA) with single rear wheels.
- This body is compatible with Factory Box Delete chassis and Aftermarket Box Removal (AMBR).
- Available for single-wheel (SW) and dual-wheel (DW) chassis.
- Available in: **SL SERIES** | **CLASSIC II STEEL** | **CLASSIC II ALUMINUM**

FOR 56" CA SRW LONG BED PICKUP

STANDARD 40" BODY

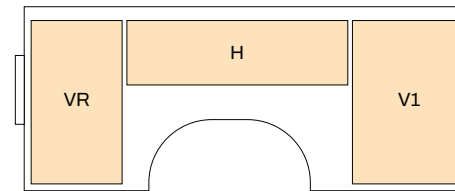

CURBSIDE VIEW

COMPARTMENT SIZES (SW/DW)

V1	28" W x 40" H	13"/20" D
H	47" W x 18.50" H	13"/20" D
VR	23" W x 40" H	13"/20" D

LENGTH 98	HEIGHT 40	WIDTH 77.5 / 91.5
TYP. WEIGHT	STEEL 999/1,114	ALUMINUM 607/691

LOW PROFILE BODY

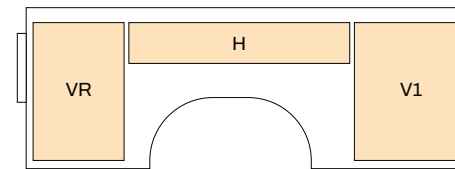

CURBSIDE VIEW

COMPARTMENT SIZES (SW/DW)

V1	28" W x 35" H	13"/20" D
H	47" W x 13.50" H	13"/20" D
VR	23" W x 35" H	13"/20" D

LENGTH 98	HEIGHT 35	WIDTH 77.5 / 91.5
TYP. WEIGHT	STEEL 996/1,114	ALUMINUM 607/691

40" BODY WITH SPACEMAKER TOP

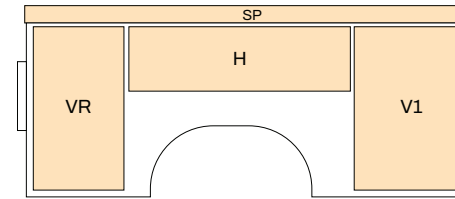

CURBSIDE VIEW

COMPARTMENT SIZES (SW/DW)

V1	28" W x 37" H	13"/20" D
H	47" W x 13.50" H	13"/20" D
VR	23" W x 37" H	13"/20" D
SP	88" W x 4.5" H	9.6"/14.5" D

LENGTH 98	HEIGHT 40	WIDTH 77.5 / 91.5
TYP. WEIGHT	STEEL 1,182/1,336	ALUMINUM 657/741

Spacemaker top-opening compartment provides 15% more storage space. Lid is offered in your choice of steel (powder coated) or bright aluminum finish.

B-COMPARTMENT LAYOUT

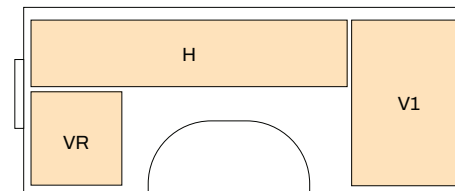

CURBSIDE VIEW

COMPARTMENT SIZES (SW/DW)

V1	28" W x 40" H	13"/20" D
H	70" W x 18.50" H	13"/20" D
VR	23" W x 21.50" H	13"/20" D

LENGTH 98	HEIGHT 40	WIDTH 77.5 / 91.5
TYP. WEIGHT	STEEL 1,046/1,164	ALUMINUM 600/672

Reading Truck offers B-compartment layout with an extended horizontal compartment for storing longer items.



108" SERVICE BODY

- The 108" service body is designed for 60" CA chassis, Class 3-5.
- Available for single-wheel (SW) and dual-wheel (DW) chassis.
- Available in: **SL SERIES** **CLASSIC II STEEL** **CLASSIC II ALUMINUM**

FOR 60" CA CHASSIS CABS, SW OR DW CLASS 3-5

STANDARD 40" BODY

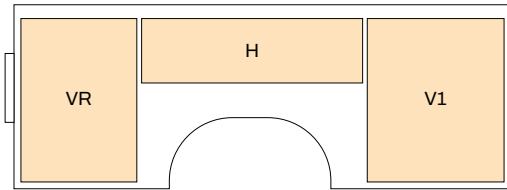

CURBSIDE VIEW

COMPARTMENT SIZES (SW/DW)

V1	33" W x 40" H	13" / 20" D
H	47" W x 18.50" H	13" / 20" D
VR	28" W x 40" H	13" / 20" D

LENGTH 108	HEIGHT 40	WIDTH 77.5/91.5
TYP. WEIGHT	STEEL 1,108/1,200	ALUMINUM 608/680

LOW PROFILE BODY

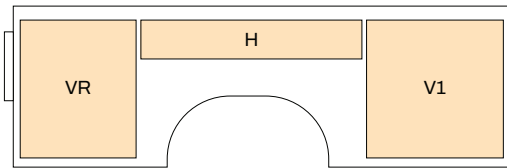

CURBSIDE VIEW

COMPARTMENT SIZES (SW/DW)

V1	33" W x 35" H	13" / 20" D
H	47" W x 13.50" H	13" / 20" D
VR	28" W x 35" H	13" / 20" D

LENGTH 108	HEIGHT 35	WIDTH 77.5/91.5
TYP. WEIGHT	STEEL 1,108/1,200	ALUMINUM 608/680

40" BODY WITH SPACEMAKER TOP

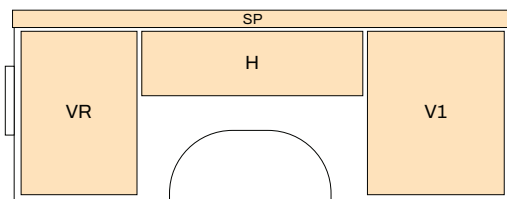

CURBSIDE VIEW

COMPARTMENT SIZES (SW/DW)

V1	33" W x 38.5" H	13" / 20" D
H	47" W x 14.75" H	13" / 20" D
VR	28" W x 38.5" H	13" / 20" D
SP	96" W x 4.5" H	9.6" / 14.5" D

LENGTH 108	HEIGHT 41	WIDTH 77.5/91.5
TYP. WEIGHT	STEEL 1,308/1,437	ALUMINUM 721/831

Spacemaker top-opening compartment provides 15% more storage space. Lid is offered in your choice of steel (powder coated) or bright aluminum finish.

B-COMPARTMENT LAYOUT

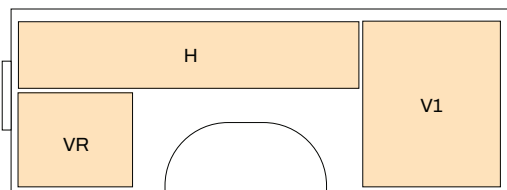

CURBSIDE VIEW

COMPARTMENT SIZES (SW/DW)

V1	33" W x 40" H	13" / 20" D
H	75" W x 18.50" H	13" / 20" D
VR	28" W x 21.50" H	13" / 20" D

LENGTH 108	HEIGHT 40	WIDTH 77.5/91.5
TYP. WEIGHT	STEEL 1,158/1,251	ALUMINUM 658/730

Reading Truck offers B-compartment layout with an extended horizontal compartment for storing longer items.



132" SERVICE BODY

- The 132" service body is designed for 84" CA chassis, Class 3-5.
- An additional front vertical compartment for extra storage space.
- Available for dual-wheel (DW) chassis only.
- Available in: **SL SERIES** **CLASSIC II STEEL** **CLASSIC II ALUMINUM**

FOR 84" CA CHASSIS CABS, CLASS 3-5

STANDARD 40" BODY

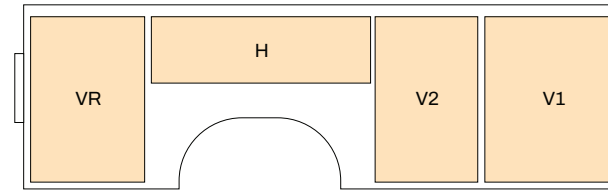

CURBSIDE VIEW

COMPARTMENT SIZES

V1	36" W x 40" H	20" D
V2	21" W x 40" H	20" D
H	47" W x 18.50" H	20" D
VR	28" W x 40" H	20" D

LENGTH 132	HEIGHT 40	WIDTH 91.5
TYP. WEIGHT	STEEL 1,502	ALUMINUM 893

LOW PROFILE BODY

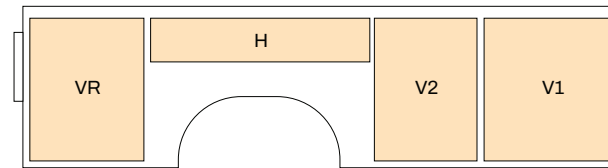

CURBSIDE VIEW

COMPARTMENT SIZES

V1	36" W x 35" H	20" D
V2	21" W x 35" H	20" D
H	47" W x 13.50" H	20" D
VR	28" W x 35" H	20" D

LENGTH 132	HEIGHT 35	WIDTH 91.5
TYP. WEIGHT	STEEL 1,450	ALUMINUM 853

40" BODY WITH SPACEMAKER TOP

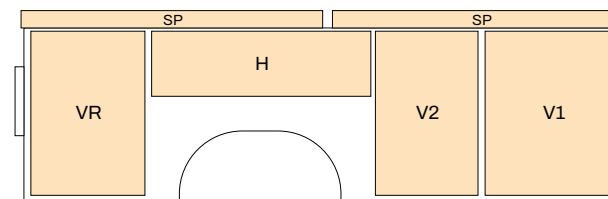

CURBSIDE VIEW

COMPARTMENT SIZES

V1	36" W x 38.5" H	20" D
V2	21" W x 38.5" H	20" D
H	47" W x 14.75" H	20" D
VR	28" W x 38.5" H	20" D
SP	52" W x 4.5" H (2)	14.5" D

LENGTH 132	HEIGHT 41	WIDTH 91.5
TYP. WEIGHT	STEEL 1,736	ALUMINUM 997

Spacemaker top-opening compartment provides 15% more storage space. Lid is offered in your choice of steel (powder coated) or bright aluminum finish.

B-COMPARTMENT LAYOUT

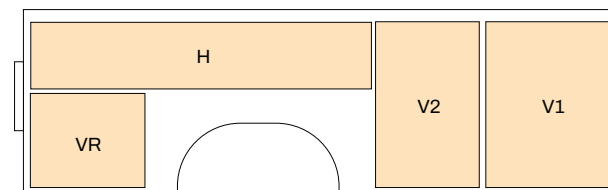

CURBSIDE VIEW

COMPARTMENT SIZES

V1	36" W x 40" H	20" D
V1	21" W x 40" H	20" D
H	75" W x 18.50" H	20" D
VR	28" W x 21.50" H	20" D

LENGTH 132	HEIGHT 40	WIDTH 91.5
TYP. WEIGHT	STEEL 1,502	ALUMINUM 893

Reading Truck offers B-compartment layout with an extended horizontal compartment for storing longer items.



HEAVY-DUTY BODY

- Lengths of 108" to 150", designed for heavy-duty use on Class 6-7 chassis.
- Available for dual-wheel (DW) chassis only.

FOR CLASS 6-7 CHASSIS

HD 108" BODY FOR 84" CA CHASSIS

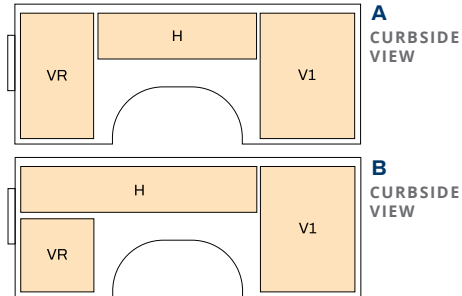

	A-LAYOUT	B-LAYOUT	
V1	34" W x 43.75" H	34" W x 43.75" H	21" D
H	47" W x 19.25" H	73.25" W x 19.25" H	21" D
VR	26" W x 43.75" H	26.25" W x 24.5" H	21" D
LENGTH 108	HEIGHT 43.75	WIDTH 93	
TYP. WEIGHT	STEEL 1,414		

HD 120" BODY FOR 72" CA CHASSIS

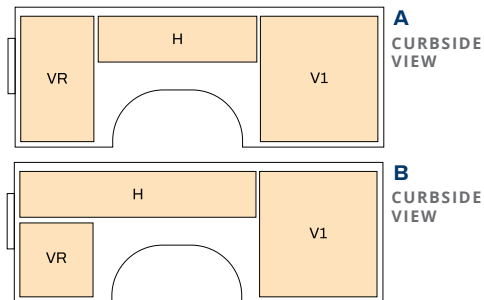

	A-LAYOUT	B-LAYOUT	
V1	34" W x 43.75" H	44" W x 43.75" H	21" D
H	49.25" W x 19.25" H	76" W x 19.25" H	21" D
VR	26.25" W x 43.75" H	26.25" W x 24.5" H	21" D
LENGTH 120	HEIGHT 43.75	WIDTH 93	
TYP. WEIGHT	STEEL 1,761		

HD 132" BODY FOR 84" CA CHASSIS

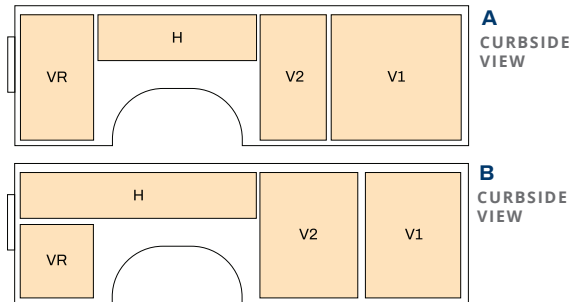

	A-LAYOUT	B-LAYOUT	
V1	38.5" W x 43.75" H	30" W x 43.75" H	21" D
V2	17.5" W x 43.75" H	26" W x 43.75" H	21" D
H	49.75" W x 19.25" H	73.25" W x 19.25" H	21" D
VR	26.25" W x 43.75" H	26.75" W x 24.5" H	21" D
LENGTH 132	HEIGHT 43.75	WIDTH 93	
TYP. WEIGHT	STEEL 2,182		

HD 150" BODY FOR 102" CA CHASSIS

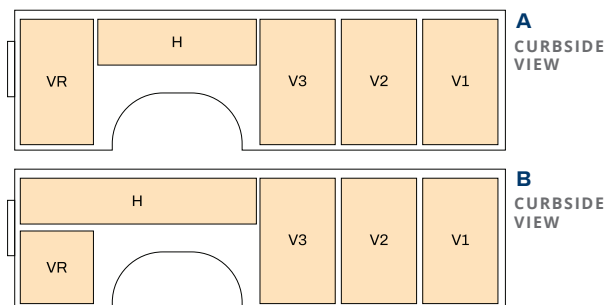

	A-LAYOUT	B-LAYOUT	
V1	26" W x 43.75" H	34" W x 43.75" H	21" D
V2	24" W x 43.75" H	24" W x 43.75" H	21" D
V3	24" W x 43.75" H	24" W x 43.75" H	21" D
H	49.75" W x 19.25" H	73.25" W x 19.25" H	21" D
VR	26.25" W x 43.75" H	26.25" W x 24.5" H	21" D
LENGTH 150	HEIGHT 43.75	WIDTH 93	
TYP. WEIGHT	STEEL 2,536		



MECHANIC SERVICE BODY

- Offers the ultimate toughness of a Mechanic's body design for non-crane applications.
- Available 60" compartments and tool-drawer units deliver ultimate versatility.
- Add an air compressor or welder setup to create a true mobile service truck for heavy industry.

FOR CLASS 3-7 CHASSIS

MM100 BODY 9' BODY FOR 60" CA CLASS 3-5 CHASSIS CAB

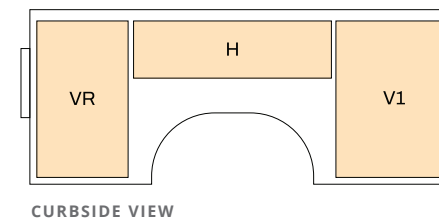

COMPARTMENT SIZES		
V1	34" W x 42" H	22" D
H	48" W x 22" H	22" D
VR	26" W x 42" H	22" D
LENGTH 108"	HEIGHT 42"	WIDTH 96"
TYP. WEIGHT	1,752 lb	

MM200 BODY 11' BODY FOR 84" CA CLASS 4-5 CHASSIS CAB

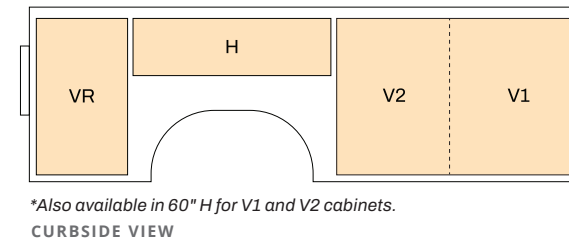

COMPARTMENT SIZES		
	CURBSIDE	ROADSIDE
V1	32.5" W x 46" H	27" W x 46" H
V2	25" W x 46" H	30" W x 46" H
H	48" W x 22" H	48" W x 22" H
VR	26.5" W x 46" H	26" W x 46" H
LENGTH 131"	HEIGHT 46"	WIDTH 96"
TYP. WEIGHT	2,987 lb	

MM200HD BODY 11' BODY FOR 84" CA CLASS 6-7 CHASSIS CAB

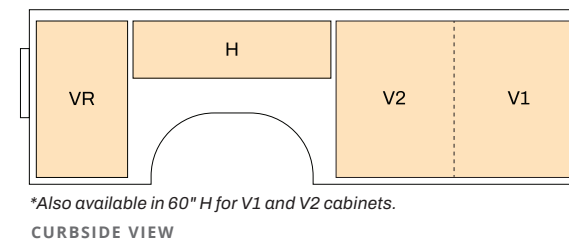

COMPARTMENT SIZES		
	CURBSIDE	ROADSIDE
V1	32" W x 50" H	28.5" W x 50" H
V2	25" W x 50" H	28.5" W x 50" H
H	50" W x 25" H	50" W x 25" H
VR	26" W x 50" H	26" W x 50" H
LENGTH 133"	HEIGHT 50"	WIDTH 96"
TYP. WEIGHT	3,138 lb	

MM300HD BODY 14' BODY FOR 120" CA CLASS 6-7 CHASSIS CAB

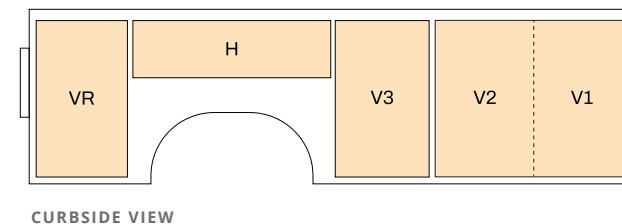

COMPARTMENT SIZES		
V1	32" W x 60" H	26" D
V2	32" W x 60" H	26" D
V3	29" W x 60" H	22" D
H	50" W x 35" H	22" D
VR	26" W x 60" H	22" D
LENGTH 169"	HEIGHT 60"	WIDTH 96"
TYP. WEIGHT	3,927 lb	

READING TRUCK WARRANTY

WARRANTIES AS STRONG AS OUR BODIES.

Your truck is the heart of your business. When it doesn't perform, you can't perform. We back our work truck bodies and installations with some of the strongest, longest warranties in the business. Product registration is fast and easy on our website, readingtruck.com.

MECHANIC SERVICE BODY



SL STEEL SERVICE BODY CLASSIC II STEEL SERVICE BODY CLASSIC II STEEL HEAVY-DUTY SERVICE BODY



CLASSIC II ALUMINUM SERVICE BODY



INSTALLATION

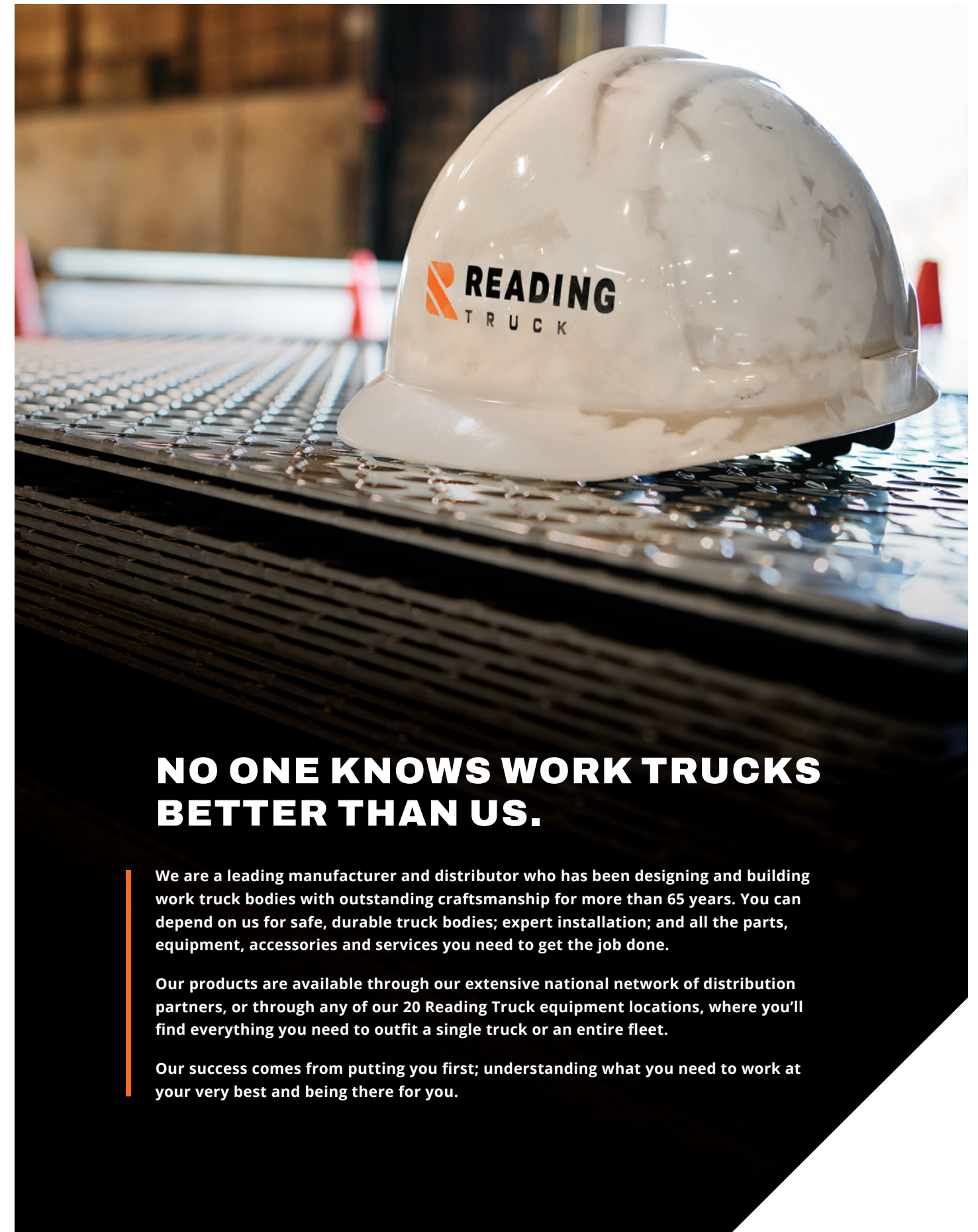
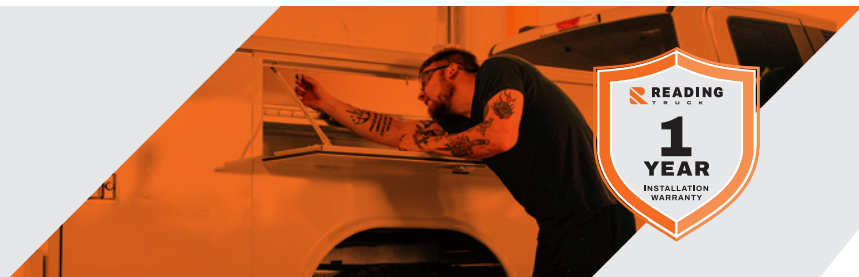

NO ONE KNOWS WORK TRUCKS BETTER THAN US.

We are a leading manufacturer and distributor who has been designing and building work truck bodies with outstanding craftsmanship for more than 65 years. You can depend on us for safe, durable truck bodies; expert installation; and all the parts, equipment, accessories and services you need to get the job done.

Our products are available through our extensive national network of distribution partners, or through any of our 20 Reading Truck equipment locations, where you'll find everything you need to outfit a single truck or an entire fleet.

Our success comes from putting you first; understanding what you need to work at your very best and being there for you.



825 E. Wyomissing Blvd.
Reading, PA 19611

readingtruck.com

Sold and Serviced Locally by



**© 2021 Reading Truck. All rights reserved.
Version Number RT21-SB-11**

All dimensions subject to plus or minus tolerance of 1/4" and all dimensions and specifications are subject to change without notice. Some items displayed in photographs are optional. Aluma-Fill, Aluma-Chock, Dual-Pro, Extend-A-Shelf, Latch-Matic, Marauder, Reading, Redi-Dek, Spacemaker, and Tool-Mates are registered trademarks of The Reading Group, LLC, (DBA Reading Truck) in the United States and some foreign countries.



LIFTGATE GUIDE

PRODUCTS • OPTIONS • APPLICATIONS



CONTENTS

10	PICKUP LIFTGATES
10	G2 Series
16	SERVICE BODY LIFTGATES
16	G2 Series
22	FLATBED, STAKE, & VAN BODY LIFTGATES
22	Tuckunder Series — TKT Models
26	Railgate Series — High-Cycle, Bi-Fold Models
28	Railgate Series — High-Cycle, Fixed-Platform Models
32	Railgate Series — Standard, Dock-Friendly Models
34	Railgate Series — Standard, Fixed-Platform Models
38	G2 Series
40	DUMP BODY LIFTGATES
40	G2 Series — Lift-N-Dump
46	CARGO VAN LIFTGATES
46	V2 Series
48	Cantilever Series
50	650 Series
51	APPLICATIONS & BRACKETS

The original
TOMMY  **GATE**
hydraulic lift



THE ORIGINAL HYDRAULIC LIFT

Woodbine Manufacturing Company is the developer of Tommy Gate, a premier brand of private, commercial, and industrial hydraulic lifts. Established in Woodbine, Iowa in 1965 by Delbert “Bus” Brown, Tommy Gate has experienced steady growth in each of the past five decades and is widely celebrated as the industry leader.

Now sold in every corner of the world, Tommy Gate’s strong reputation for quality has been built through a strict adherence to the highest standards of engineering, craftsmanship, and customer service.

START HERE

Tommy Gate offers a full line of liftgates for any personal, commercial, or industrial application. Depending on your particular cargo-handling needs and your vehicle, certain liftgates may be more suitable than others. This guide is intended to help you most easily identify which Tommy Gate hydraulic lift is right for you.



RAILGATE
SERIES

HIGH-CYCLE MODELS

A level-ride liftgate ideal for handling heavy, sensitive, wheel-based cargo.

⬆️ 2500 - 3000 LBS CAPACITY



CANTILEVER
SERIES

A modern lift that is specifically designed to operate seamlessly with commercial vans.

⬆️ 1300 LBS CAPACITY

650

Low-capacity, compact, and internally-mounted; an ideal liftgate for lightweight vans.



⬆️ 650 LBS CAPACITY



A dual-cylinder, parallel-arm design liftgate. Versatile, popular, and modern.



⬆️ 1300 - 2000 LBS CAPACITY

RAILGATE
SERIES

STANDARD MODELS

A level-ride liftgate ideal for handling heavy, sensitive, wheel-based cargo.



⬆️ 1600 - 2000 LBS CAPACITY

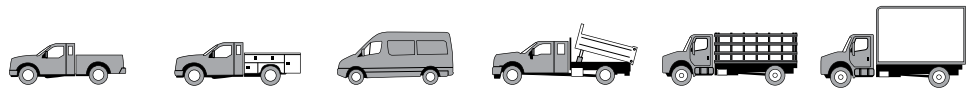

	✓ PAGE 10	✓ PAGE 16	—	✓ PAGE 38	✓ PAGE 38	✓ PAGE 38
TUCKUNDER SERIES	—	—	—	—	✓ PAGE 22	✓ PAGE 22
RAILGATE SERIES	—	—	—	—	✓ PAGE 28	✓ PAGE 26
RAILGATE SERIES	—	—	—	—	✓ PAGE 34	✓ PAGE 32
V2 SERIES	—	—	✓ PAGE 46	—	—	—
CANTILEVER SERIES	—	—	✓ PAGE 48	—	—	—
650	—	—	✓ PAGE 50	—	—	—



NEW



The all-new internal van lift. Provides wide loading area, hands-free platform operation, and retention ramp for wheeled cargo.

⬆ 1100 LBS CAPACITY

TUCKUNDER

SERIES

TKT MODELS

Tommy Gate's elite tuckunder lift. State-of-the-art design and loaded with standard features.



⬆ 2500 - 3000 LBS CAPACITY







THE INDUSTRY STANDARD

The Tommy Gate G2 Series is a dual-cylinder, parallel-arm design which utilizes a pair of hydraulic cylinders to lower and raise the lift by applying direct power to both sides of the platform. G2 Series liftgates for pickups are versatile, popular, and modern.

G2-60-1542 EA38

Shown with optional rubber platform bumpers and discontinued recessed light kit. Recessed lights have been replaced by a bolt-on kit.

Frames and platforms on every G2 Series liftgate are hand assembled and hand welded, while precision parts are laser cut and/or robotically welded.



DUAL-DRIVE ADVANTAGES

Dual-drive liftgates provide increased durability for rigorous cycling and have low maintenance requirements. A paint-before-assembly process also increases the longevity of the lift's aesthetics.

G2 SERIES LIFTGATE FEATURES

- Dual hydraulic cylinders
- Virtually maintenance-free components
- Recessed control
- Larger platforms
- Fully-enclosed hydraulic system located within the lift mainframe



AVAILABLE MODELS

TWO-YEAR STANDARD WARRANTY

	Model Number	Load Area	Taper	Travel	Platform Fold	Application ¹	Gate Weight
1300 lb. Capacity	Treadplate Platforms						
	G2-60-1342 TP27	55 x 27	4	42	No	A,B	438
	G2-60-1342 TP38	55 x 38	4	42	Yes	A,B	478
	G2-60-1342 TP42	55 x 42	7	42	Yes	A,B	503
	TommyTraction™ Platform						
	G2-60-1342 TT27	55 x 27	4	42	No	A,B	439
	Aluminum Platforms						
	G2-60-1342 EA27	55 x 27	6	42	No	A,B	395
	G2-60-1342 EA38	55 x 38	6	42	Yes	A,B	421
	G2-60-1342 EA48 ²	55 x 48	6	42	Yes	A,B	442
Bar Grate Platform							
G2-60-1342 BG27	55 x 27	4	42	No	A,B	445	

1500 lb. Capacity	Treadplate Platforms						
	G2-60-1542 TP27	55 x 27	4	42	No	B	438
	G2-60-1542 TP38	55 x 38	4	42	Yes	B	478
	G2-60-1542 TP42	55 x 42	7	42	Yes	B	503
	TommyTraction™ Platform						
	G2-60-1542 TT27	55 x 27	4	42	No	B	439
	Aluminum Platforms						
	G2-60-1542 EA27	55 x 27	6	42	No	B	395
	G2-60-1542 EA38	55 x 38	6	42	Yes	B	421
	G2-60-1542 EA48 ²	55 x 48	6	42	Yes	B	442
Bar Grate Platform							
G2-60-1542 BG27	55 x 27	4	42	No	B	445	

G2 MODELS FOR MID-SIZED PICKUPS





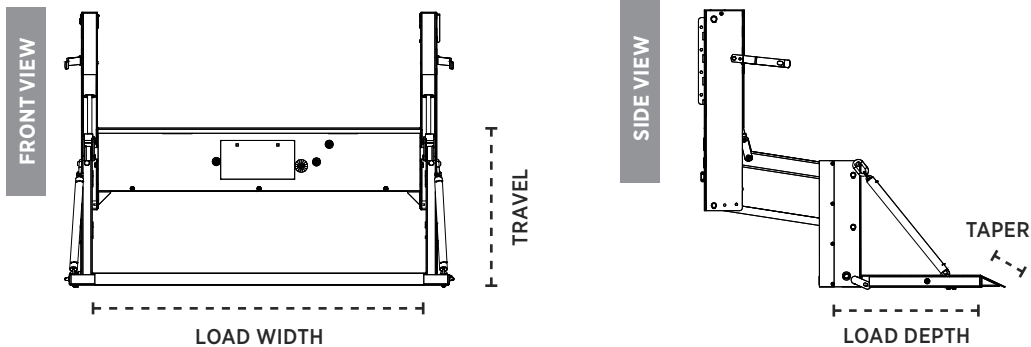

750 lb. Capacity	Treadplate Platforms						
	G2-54-7542 TP38	49 x 38	4	42	Yes	G	421
	Aluminum Platforms						
G2-54-7542 EA38	50 x 38	6	42	Yes	G	369	

G2 SERIES DIMENSIONS ³









1. See applications on page 51.
2. EA48 platform extends 10" above top of liftgate mainframe. See image on page 13.
3. For detailed dimensions, visit www.tommygate.com



STANDARD FEATURES



	Fixed and Timed Toggle Control
	Recessed Control
	Vehicle-specific Mounting Brackets
	Power Cable with Full-length Ground
	150-amp Circuit Breaker
	Maintenance-free Pins and Bushings
	Drop-away Platform
	Hitch Compatible ¹

AVAILABLE OPTIONS

	Remote Pendant Control
	Dual Controls
	Rubber Platform Bumpers
	Bolt-on, 3-Light, LED Light Kit
	Bolt-on, 2-Light, LED Light Kit
	Galvanized Frame and Platform ³
	Rear Camera and Sensor Bar
	Folding Tire Rack ²

1. Compatible with many hitches. Visit www.tommygate.com to view complete hitch chart.
2. Not compatible with folding platforms. See spec charts.
3. Galvanized option not available with Steel Treadplate platforms. Call factory for ordering details.

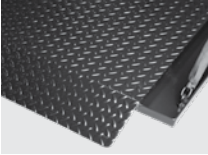
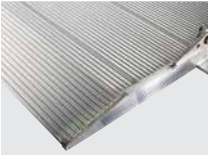
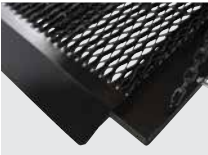
PLATFORM MATERIALS

	Steel Treadplate
	Extruded Aluminum
	TommyTraction
	Steel Bargrate

GALVANIZING OPTION

A high-quality galvanized finish supports long-lasting performance and appearance in even the most extreme climate conditions.

*Not available with Steel Treadplate platforms.
Call factory for ordering details.*



STEEL PLATFORMS

TP27 - 27" Loading Depth

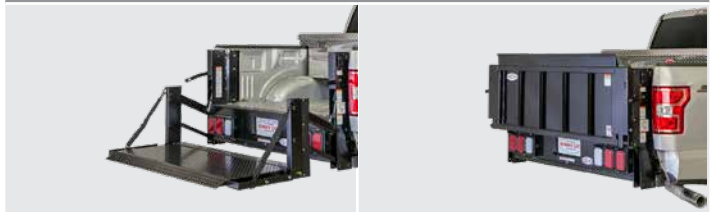

TP38 - 38" Loading Depth



TP42 - 42" Loading Depth

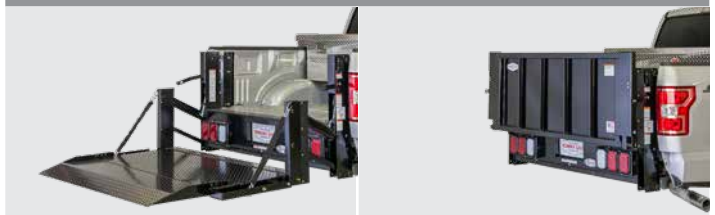

ALUMINUM PLATFORMS

EA27 - 27" Loading Depth



EA38 - 38" Loading Depth



EA48 - 48" Loading Depth (EXTENDS ABOVE TRUCK BOX)



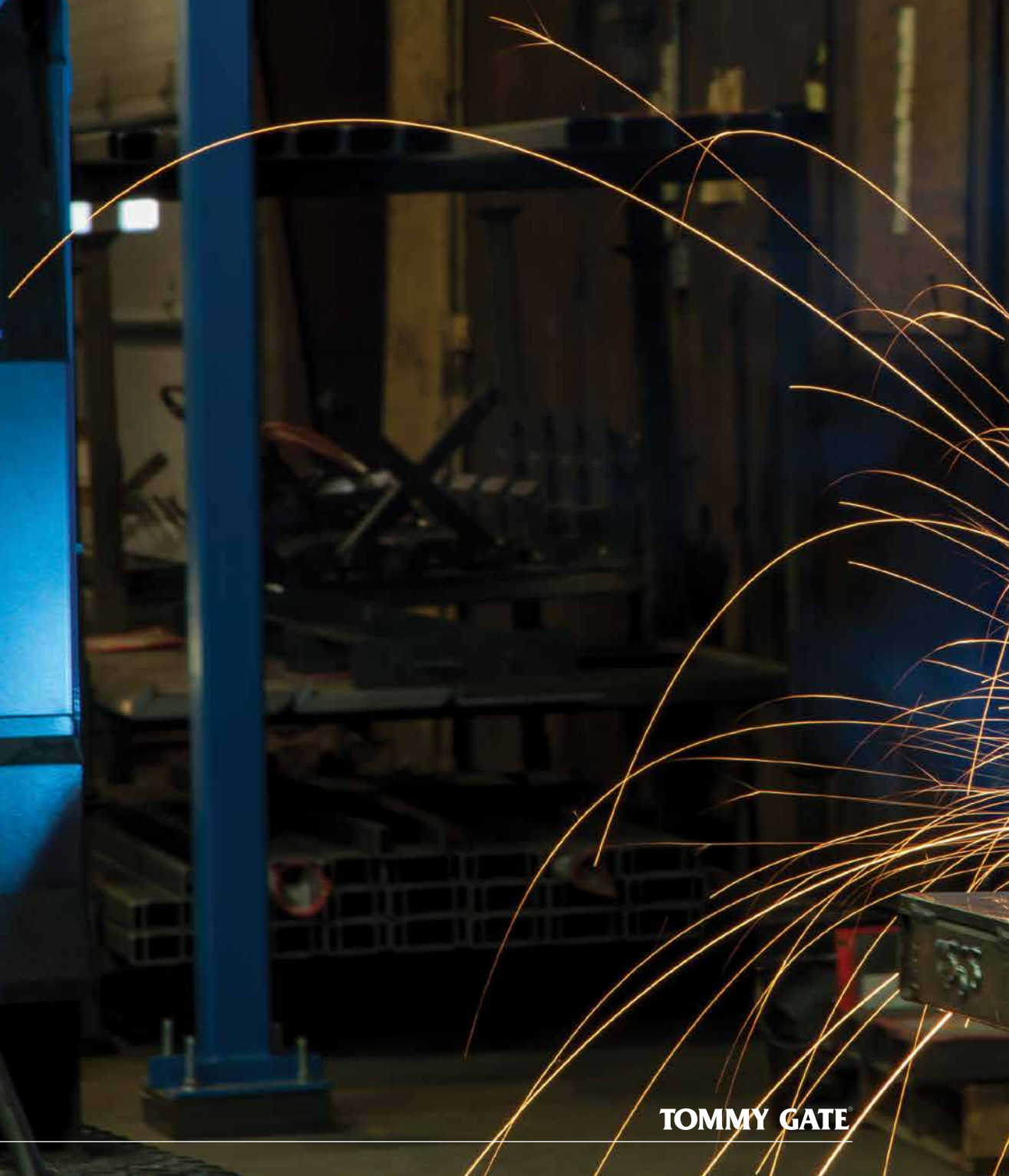



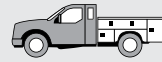

THE INDUSTRY STANDARD

The Tommy Gate G2 Series is a dual-cylinder, parallel-arm design which utilizes a pair of hydraulic cylinders to lower and raise the lift by applying direct power to both sides of the platform. With forty-two inches of vertical travel, the G2 Series is a great fit for most any service body.

G2-60-1542 EA38

Shown with optional rubber platform bumpers and discontinued recessed light kit. Recessed lights have been replaced by a bolt-on kit.

Hydraulic cylinders are built in-house. Precision cylinder welds are executed by robotic machines, while assembly and testing are done by hand.



G2 SERIES LIFTGATE FEATURES

- Dual hydraulic cylinders
- Virtually maintenance-free components
- Recessed control
- Larger platforms
- Fully-enclosed hydraulic system located within the liftgate mainframe



Dual-drive liftgates provide increased durability for rigorous cycling and have low maintenance requirements. A paint-before-assembly process also increases the longevity of the lift's aesthetics.



MODELS FOR SERVICE BODIES WITH 48" OPENING

TWO-YEAR STANDARD WARRANTY

	Model Number	Load Area	Taper	Travel	Platform Fold	Gate Weight
1300 lb. Capacity	Treadplate Platforms					
	G2-54-1342 TP27	49 x 27	4	42	No	415
	G2-54-1342 TP38	49 x 38	4	42	Yes	453
	G2-54-1342 TP42	49 x 42	7	42	Yes	477
	TommyTraction™ Platform					
	G2-54-1342 TT27	50 x 27	4	42	No	416
	Aluminum Platforms					
	G2-54-1342 EA27	49 x 27	6	42	No	375
	G2-54-1342 EA38	49 x 38	6	42	Yes	399
	G2-54-1342 EA48 ¹	49 x 48	6	42	Yes	419
Bar Gate Platform						
G2-54-1342 BG27	50 x 27	4	42	No	422	
1600 lb. Capacity	Treadplate Platforms					
	G2-54-1642 TP27	49 x 27	4	42	No	415
	G2-54-1642 TP38	49 x 38	4	42	Yes	453
	G2-54-1642 TP42	49 x 42	7	42	Yes	477
	TommyTraction™ Platform					
	G2-54-1642 TT27	50 x 27	4	42	No	416
	Aluminum Platforms					
	G2-54-1642 EA27	49 x 27	6	42	No	375
	G2-54-1642 EA38	49 x 38	6	42	Yes	399
	G2-54-1642 EA48 ¹	49 x 48	6	42	Yes	419
Bar Gate Platform						
G2-54-1642 BG27	50 x 27	4	42	No	422	

ADDITIONAL BODY SIZES







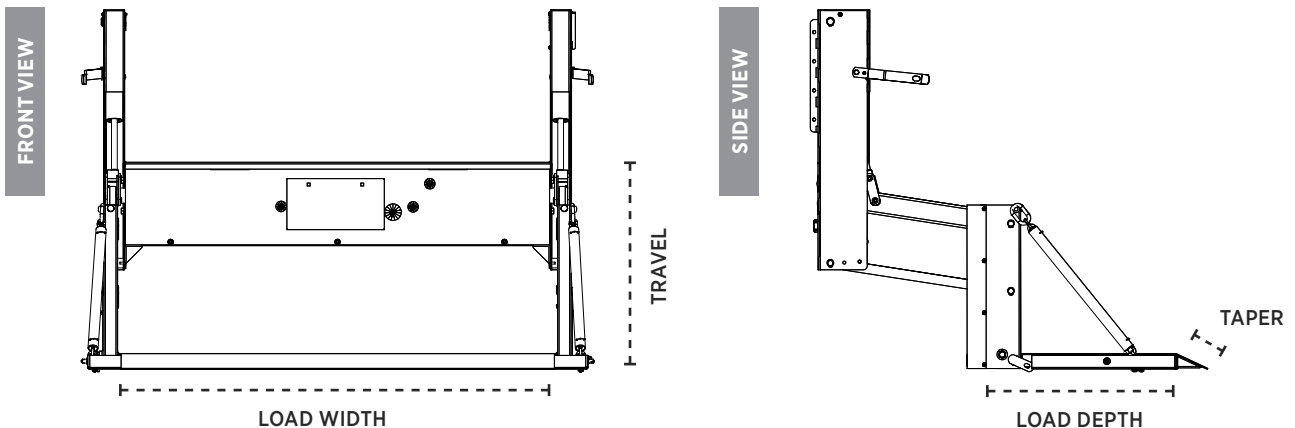

Body Opening	Model	Description
54"	60SB	55" Load Area width

1. See applications on page 51.
2. EA48 platform extends 10" above top of liftgate mainframe. See image on page 19.
3. For detailed dimensions, visit www.tommygate.com







G2 SERIES DIMENSIONS ³



STANDARD FEATURES

	Fixed and Timed Toggle Control
	Recessed Control
	Vehicle-specific Mounting Brackets
	Power Cable with Full-length Ground
	150-amp Circuit Breaker
	Maintenance-free Pins and Bushings
	Drop-away Platform
	Hitch Compatible ¹

AVAILABLE OPTIONS

	Remote Pendant Control
	Dual Controls
	Rubber Platform Bumpers
	Bolt-on, 3-Light, LED Light Kit
	Bolt-on, 2-Light, LED Light Kit
	Folding Tire Rack ²
	Galvanized Frame and Platform ³

PLATFORM DROP-CHAIN COVERS PROVIDE A QUIETER RIDE.



1. Compatible with many hitches. Visit www.tommygate.com to view complete hitch chart.
2. Not compatible with folding platforms. See spec charts.
3. Galvanized option not available with Steel Treadplate platforms. Call factory for ordering details.

PLATFORM MATERIALS

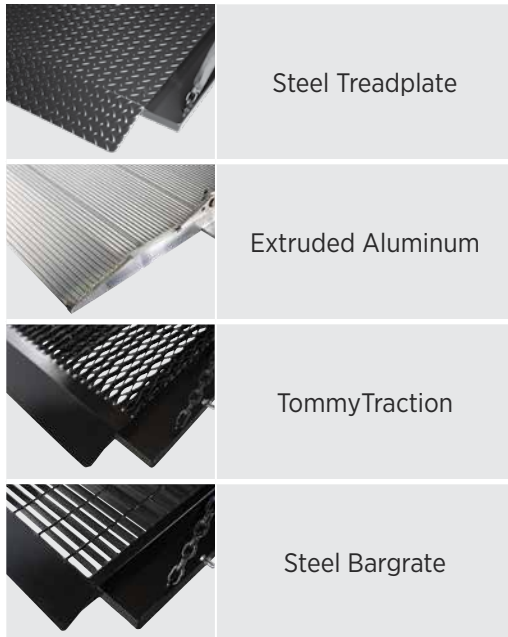

GALVANIZING OPTION

A high-quality galvanized finish supports long-lasting performance and appearance in even the most extreme climate conditions.

*Not available with Steel Treadplate platforms.
Call factory for ordering details.*



STEEL PLATFORMS

TP27 - 27" Loading Depth



TP38 - 38" Loading Depth



ALUMINUM PLATFORMS

EA38 - 38" Loading Depth



EA48 - 48" Loading Depth (EXTENDS ABOVE TRUCK BOX)



ALUMINUM PLATFORMS ARE COMPRISED OF INTERLOCKING, 6061-T6 AIRCRAFT-QUALITY EXTRUSIONS.







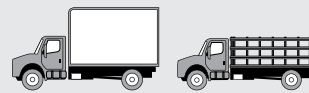

TKT MODELS

TKT models address all the concerns a liftgate operator faces. With self-leveling and power down functions, the lift is simple to use and reliable. The large platforms easily accommodate pallet-sized loads. And, the wide-arm, dual-cylinder design assures sturdy and consistent lifting action.

TKT Models are outfitted with numerous design features including hydraulic power-down and self-leveling actions for optimal control, a molded-plastic power unit cover that protects vital parts from outside elements, and a low-profile control with 5-minute inactivity shut-off to guard against unauthorized usage.

TKT-80-30 EA60

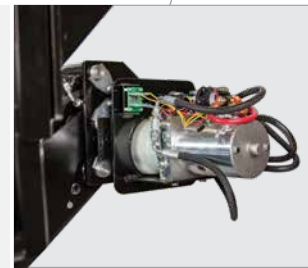

BED EXTENSIONS

All Tuckunder Series liftgates are sold with a body-width bed extension. Both “standard” strength, 3/16-inch, steel construction bed extensions and “heavy duty” strength, 3/8-inch, versions are available.

All Tuckunder Series bed extensions come with standard 24-inch, rubber dock bumpers and bolt-on adjustable steps.

TKT-80-30 EA60



AVAILABLE MODELS (DUAL-CYLINDER, POWER-DOWN, SELF-LEVELING)

TWO-YEAR STANDARD WARRANTY

	Model Number	Load Area	Bed Heights ¹	Gate Weight ²
2500 lb. Capacity	Treadplate Platforms			
	TKT-80-25 TP50	80 x 50	40-54	887
	TKT-80-25 TP60	80 x 60	45-54	980
	Aluminum Platforms			
	TKT-80-25 EA50	80 x 50	40-54	816
	TKT-80-25 EA60	80 x 60	45-54	866
3000 lb. Capacity	Treadplate Platforms			
	TKT-80-30 TP50	80 x 50	40-54	887
	TKT-80-30 TP60	80 x 60	45-54	980
	Aluminum Platforms			
	TKT-80-30 EA50	80 x 50	40-54	816
	TKT-80-30 EA60	80 x 60	45-54	866

AVAILABLE BED EXTENSION OPTIONS

Body Size	Extension Type	Extension Weight	Description
96"	Standard	276	"standard" strength 3/16-inch thick steel construction
96"	Heavy Duty	334	"heavy duty" strength 3/8-inch thick steel construction
102"	Standard	283	"standard" strength 3/16-inch thick steel construction
102"	Heavy Duty	341	"heavy duty" strength 3/8-inch thick steel construction

TKT MODEL DIMENSIONS ³

ABOVE VIEW

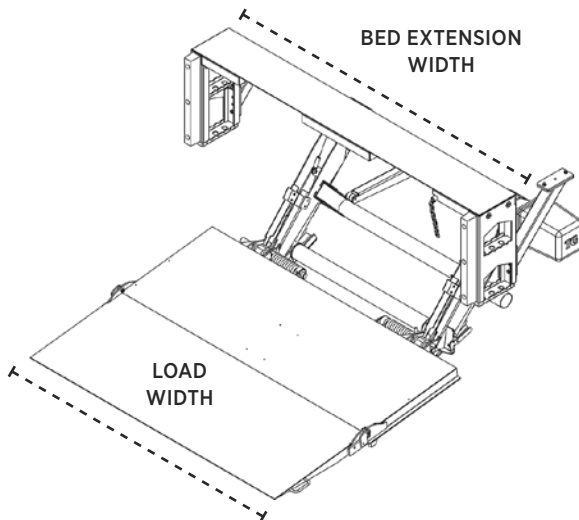



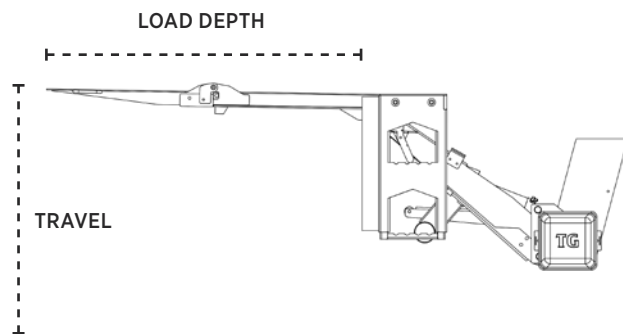



SIDE VIEW







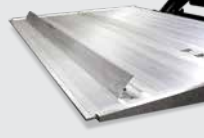

1. Minimum bed heights (laden), Maximum bed heights (unladen).
2. Must add bed extension weight for total gate weight.
3. For detailed dimensions, visit www.tommygate.com

STANDARD FEATURES

	Power Down
	Underride Impact Guard
	Low-profile, Fixed Toggle Control
	Snubber Kit
	Standard, 38 ft., Power Cable with Full-length Ground
	24-inch, Rubber Dock Bumpers
	Bolt-on Adjustable Steps

AVAILABLE OPTIONS

	Split Cart Stops ¹
	2-Light, LED Light Kit
	Dual Controls
	Extended, 41 ft., Power Cable with Full-length Ground
<i>NO IMAGE</i>	24-volt System
	In-Line Power Shut-Off
	License Plate Mount
	Auxiliary Battery Box

1. Extruded Aluminum platforms lose 10 inches of loading depth when cart stops are deployed.

Like all Tommy Gate hydraulic lifts, the main assembly of the Tuckunder Series is cut from raw steel, formed into precision parts, and hand-welded. TKT models are then **painted before assembly** to reduce exposure and corrosion. This entire process is completed on site at the Tommy Gate factory in Woodbine, Iowa.

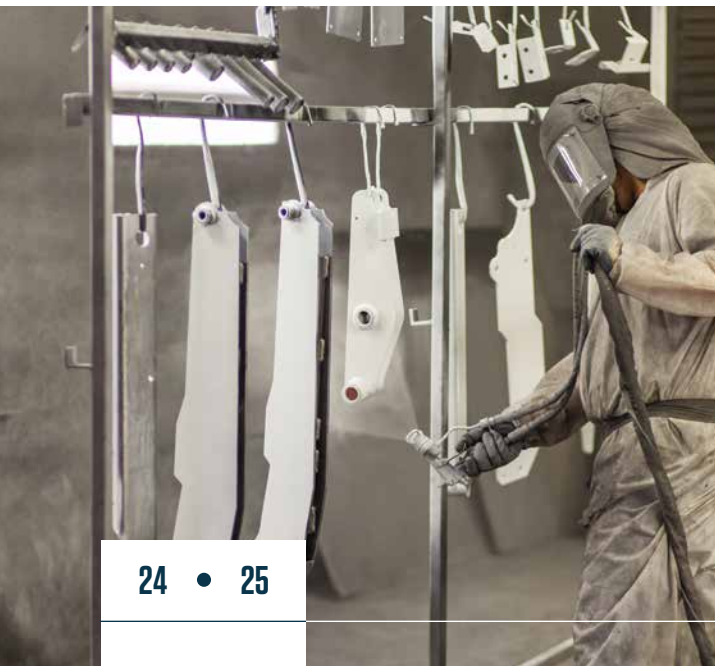

PLATFORM MATERIALS

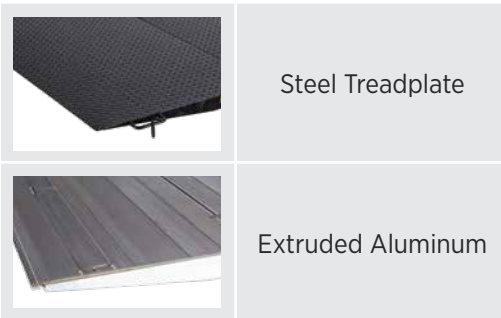

SPLIT CART STOPS

Aluminum platforms are available with foot-activated, dual cart stops. Platform loses 10 inches of loading depth when the cart stops are deployed.



EASY-TO-HANDLE PLATFORMS

All TKT Models are equipped with coiled torsion springs in both the main platform and “flipper” hinge points to make the folding and unfolding of Tuckunder Series platforms as easy as possible.



PLATFORMS

Both the extruded aluminum and treadplate steel platforms have clean, flat loading areas. Aluminum platforms also utilize a flat platform hinge for maximum convenience.



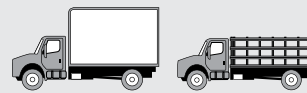

RAILGATE SERIES - HIGH-CYCLE MODELS WITH BI-FOLD PLATFORMS

📈 2500 & 3000 LBS CAPACITY



BI-FOLD RAILGATE MODELS

The most versatile, dependable liftgates ever seen in a loading bay, Bi-Fold, High-Cycle models support large steel platforms and high lifting capacities while still remaining completely dock-compatible. The platform drop-down function allows work vehicles to load and unload in any manner at any location.

TKT-80-30 EA60

In the drop-away position, Bi-Fold Railgate platforms rest at bed height, allowing seamless dock compatibility.

The Low-Profile Control, a standard feature on all Tommy Gate Railgate models, includes an inactivity shut-off to guard against unauthorized use.



BI-FOLD RAILGATE FEATURES

- A SAFETY TRIP BAR** disengages the lift when an object is detected between the rising platform and the liftgate mainframe
- B LOW-PROFILE CONTROL** reduced size simplifies operation
- C SELF-CLOSE ARM** cam-arm system opens/closes the platform automatically

TWO-YEAR STANDARD WARRANTY

BI-FOLD, HIGH-CYCLE MODELS FOR 96- & 102-INCH WIDE BODIES¹

	Model Number	Body	Load Area	Taper ²	Bed Heights ³	Gate Weight
2500 lb. Capacity	<u>Treadplate Platforms</u>					
	89-25 BF TP60	96	83 x 60	13	34 - 54	1320
	89-25 BF TP70	96	83 x 70	13	38 - 54	1378
	95-25 BF TP60	102	89 x 60	13	34 - 54	1362
	95-25 BF TP70	102	89 x 70	13	38 - 54	1420
3000 lb. Capacity	<u>Treadplate Platforms</u>					
	89-30 BF TP60	96	83 x 60	13	34 - 54	1320
	89-30 BF TP70	96	83 x 70	13	38 - 54	1378
	95-30 BF TP60	102	89 x 60	13	34 - 54	1362
	95-30 BF TP70	102	89 x 70	13	38 - 54	1420

BI-FOLD, HIGH-CYCLE RAILGATE DIMENSIONS

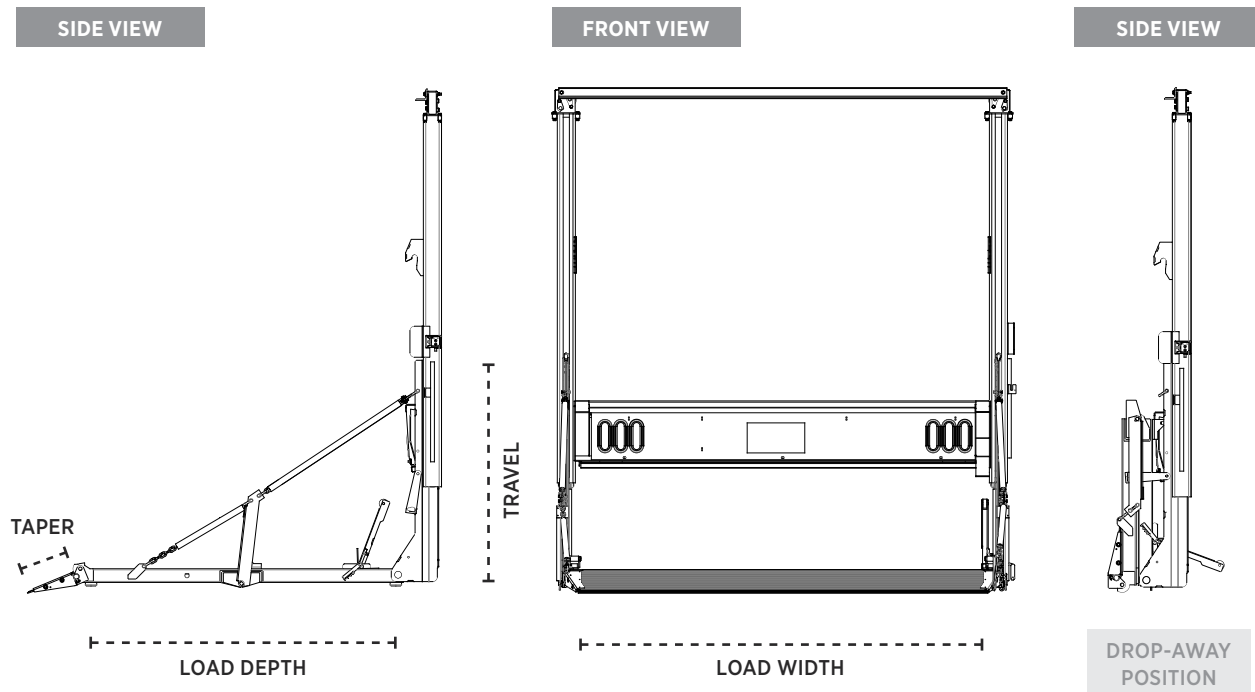

IMPORTANT

High-cycle railgate models are intended for use on medium-duty trucks only.

1. Bi-Fold, High-Cycle configurations for additional body widths may be available. Contact factory for details.
2. Standard, aluminum retention ramp serves as 13-inch, folding, platform taper on Bi-Fold Railgate models.
3. Minimum bed heights (laden), Maximum bed heights (unladen).



2500 & 3000 LBS CAPACITY

HIGH-CYCLE RAILGATE MODELS

High-cycle models apply a steel roller and leaf-chain pulley system to maximize smoothness of motion, endurance, and strength. This medium-duty railgate is ideal for high-cycle applications in any environment. These lifts are built with the highest quality components and place a priority on function and safety.

89-30 EA55



High-cycle railgates come standard with safety trip bar, auto open and close, and recessed lights. Taper-integrated cart stops are optional on extruded-aluminum platform models.



ROLLERS

Steel rollers guide the platform vertically within the rail track and are designed to withstand intensive cycling. Dual-sealed, maintenance-free ball bearings ensure the rollers are long-lasting and perform consistently in all climate conditions.



HIGH-CYCLE MODELS FOR 96" WIDE BODIES¹

TWO-YEAR STANDARD WARRANTY

	Model Number	Body	Load Area	Taper	Bed Heights	Gate Weight
2500 lb. Capacity	Treadplate Platforms					
	89-25 TP36	96	89 x 36	12	32 - 54	1040
	89-25 TP42	96	89 x 42	12	32 - 54	1094
	89-25 TP48	96	89 x 48	12	32 - 54	1147
	Aluminum Platforms ¹					
	89-25 EA55	96	89 x 55	12	32 - 54	968
	Gas Bottle Rack Platforms					
89-25 GBR	96	82 x 30	12	38 - 54	1050	
3000 lb. Capacity	Treadplate Platforms					
	89-30 TP36	96	89 x 36	12	32 - 54	1040
	89-30 TP42	96	89 x 42	12	32 - 54	1094
	89-30 TP48	96	89 x 48	12	32 - 54	1147
	Aluminum Platforms ¹					
	89-30 EA55	96	89 x 55	12	32 - 54	968
	Gas Bottle Rack Platforms					
89-30 GBR	96	82 x 30	12	38 - 54	1050	

ADDITIONAL BODY SIZES

Body Size	Model	Load Width
90"	85	85
102"	95	95

IMPORTANT

High-cycle railgate models are intended for use on medium-duty trucks only.



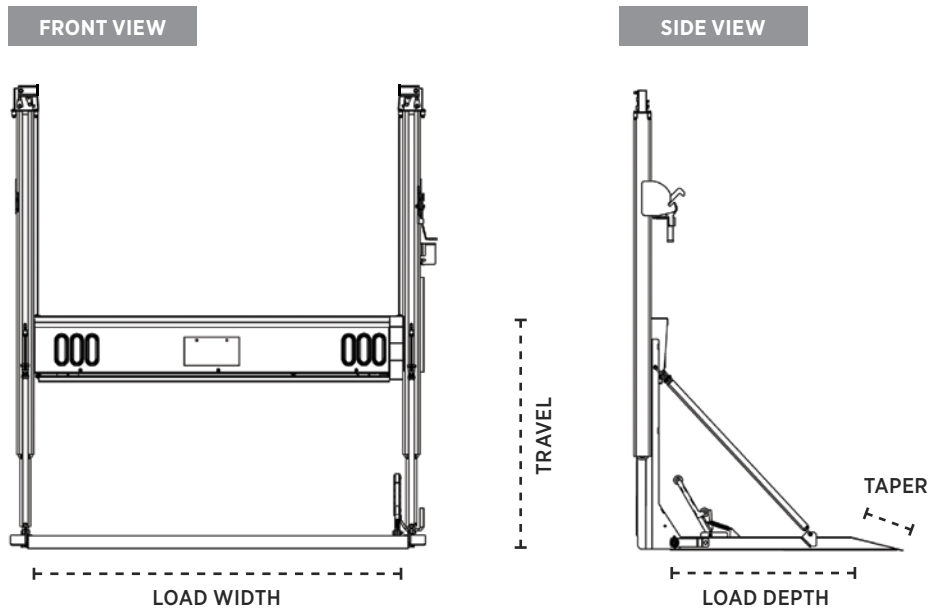

1. See additional aluminum platform depths on page 31.
2. For detailed dimensions, visit www.tommygate.com

HIGH-CYCLE RAILGATE DIMENSIONS²



STANDARD FEATURES



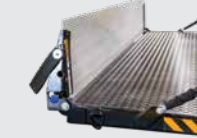



**BI-FOLD
MODELS** **FIXED
PLATFORM
MODELS**

	Steel Rollers	●	●
	Safety Trip Bar	●	●
	Self-close System	●	●
	Recessed Lights	●	●
	Low-profile Control	●	●
	13" Retention Ramp	●	-

- Standard
- Optional
- Not Available

AVAILABLE OPTIONS

**BI-FOLD
MODELS** **FIXED
PLATFORM
MODELS**

	Above Bed Travel	●	●
	Recessed LED Lights	●	●
	Dual Controls (w/ pendant)	●	●
	Split Cart Stops	-	●
	In-cab Shut Off	●	●
	Auxiliary Battery Box	●	●

GAS-BOTTLE RACK PLATFORM

High-Cycle Gas Bottle Rack models incorporate the “High-Cycle” drive system and feature folding, gas bottle rack platforms. Ideal for gas cylinder transporters, these liftgates support higher lifting capacities and feature a platform drop-down function allowing work vehicles to load and unload in any manner at any location.



PLATFORM MATERIALS

**BI-FOLD
MODELS** **FIXED
PLATFORM
MODELS**

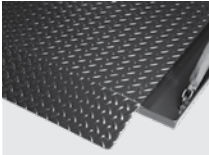
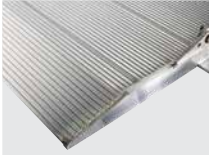
	Steel Treadplate	●	●
	Extruded Aluminum	-	●

ALUMINUM PLATFORM DEPTHS

Extruded aluminum platforms (on fixed platform models) are available in any depth, 35" - 70", in 5" increments. Platforms are comprised of interlocking extrusions of 6061-T6 aircraft-quality aluminum.



RETENTION RAMP

Bi-Fold, High-Cycle models come standard with a 13" tapered, retention ramp.

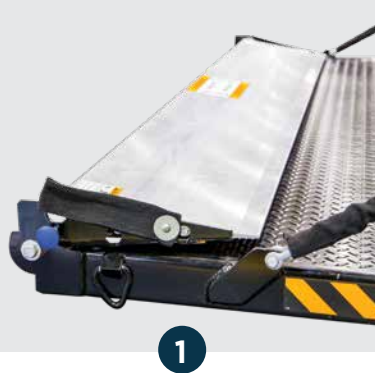

1 ramp closes for storage



2 ramp locks at 90-degrees for cart retention

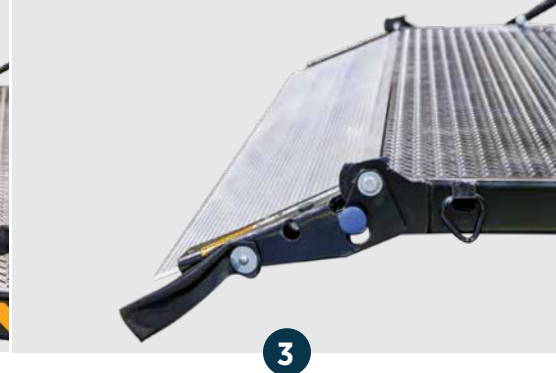

3 extended ramp hangs beyond platform level for smooth ground every time

SPLIT CART STOPS

All railgate models with Extruded Aluminum platforms are available with taper-integrated, foot-activated, dual cart stops.



FLATBED, STAKE, & VAN BODY



RAILGATE
SERIES

RAILGATE SERIES - STANDARD MODELS WITH DOCK-FRIENDLY PLATFORMS

↑ 1600 & 2000 LBS CAPACITY



DOCK-FRIENDLY RAILGATE MODELS

Dock-friendly models feature folding RF platforms able to achieve non-obstructing positions for forklift or dock loading. Also included are a closure-assist torsion bar and maintenance-free bushings, making them some of the best liftgates ever seen in a loading bay.

◀ 89-20 RF 45-12

Dock-friendly platforms fold and can be lowered in the vertical position to allow for easy dock or forklift loading.



1

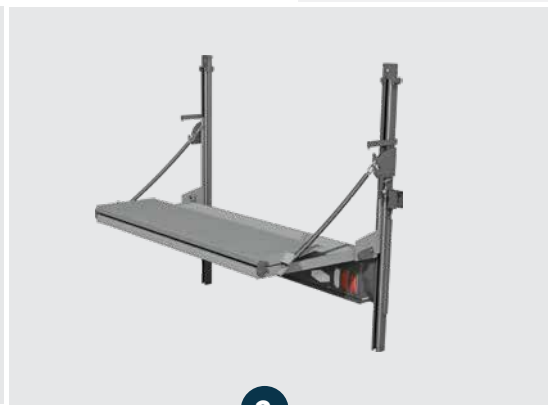

2



3

PLATFORM DESCRIPTIONS

- RF 45-6** Two-piece Extruded Aluminum w/ 45" loading depth (15" flipper) + 6" taper (**30" base height**)
- RF 45-12** Two-piece Extruded Aluminum w/ 45" loading depth (10" flipper) + 12" taper (**35" base height**)
- RF 50-6** Two-piece Extruded Aluminum w/ 50" loading depth (15" flipper) + 6" taper (**35" base height**)

DOCK-FRIENDLY, STEEL-FRAME MODELS FOR 96" WIDE BODIES

ONE-YEAR STANDARD WARRANTY

	Model Number	Load Area	Taper	Travel	Gate Weight
1600 lb. Capacity	Folding Aluminum Platforms				
	89-16 RF 45-6	89 x 45	6	32 - 52	674
	89-16 RF 45-12	89 x 45	12	32 - 52	688
	89-16 RF 50-6	89 x 50	6	32 - 52	695
2000 lb. Capacity	Folding Aluminum Platforms				
	89-20 RF 45-6	89 x 45	6	32 - 52	674
	89-20 RF 45-12	89 x 45	12	32 - 52	688
	89-20 RF 50-6	89 x 50	6	32 - 52	695

DOCK-FRIENDLY, ALUMINUM-FRAME MODELS FOR 96" WIDE BODIES ¹

	Model Number	Load Area	Taper	Travel	Gate Weight
1600 lb. Capacity	Folding Aluminum Platforms				
	A85-16 RF 45-6	85 x 45	6	32 - 52	539
	A85-16 RF 45-12	85 x 45	12	32 - 52	553
	A85-16 RF 50-6	85 x 50	6	32 - 52	559
2000 lb. Capacity	Folding Aluminum Platforms				
	A85-20 RF 45-6	85 x 45	6	32 - 52	539
	A85-20 RF 45-12	85 x 45	12	32 - 52	553
	A85-20 RF 50-6	85 x 50	6	32 - 52	559

ADDITIONAL BODY SIZES

Body Size	Model	Load Width
90"	85	85
102"	95	95

1. Aluminum-Frame "Dock-Friendly" Railgate models are sized down due to the accompanying bolt-on mounting flanges. Contact factory for more details.
2. For detailed dimensions, visit www.tommygate.com

DOCK-FRIENDLY RAILGATE DIMENSIONS ²

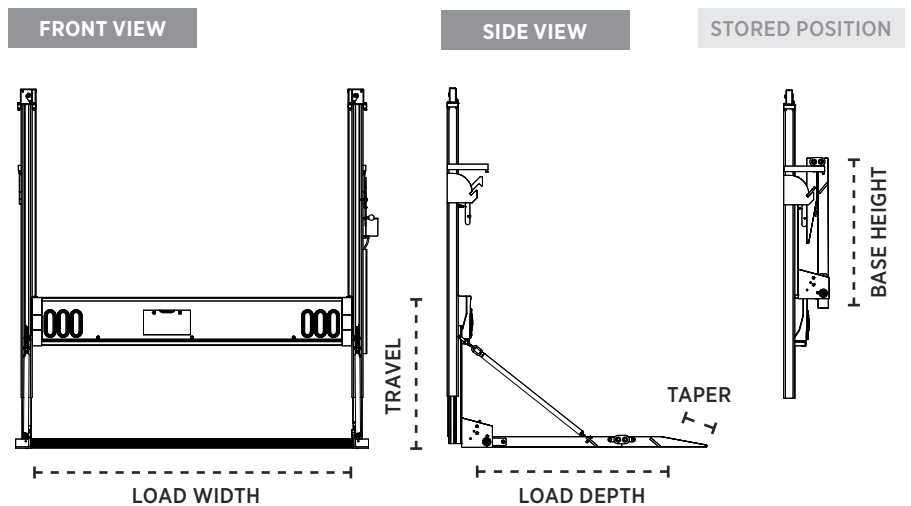

FLATBED, STAKE, & VAN BODY



RAILGATE
SERIES

RAILGATE SERIES - STANDARD MODELS WITH FIXED PLATFORMS

↑ 1600 & 2000 LBS CAPACITY

STANDARD RAILGATE MODELS

The Tommy Gate Railgate Series consists of expertly-engineered lifts that allow for higher weight capacities and deeper platform loading areas. Standard model railgates employ a padded-slider system and are offered in both steel and aluminum frames.



89-20 EA55

1600 and 2000 lb. capacity railgates come standard with safety trip bar, auto close, and recessed lights.

(Optional LED light kit shown)



ABOVE-BED OPTIONAL CAPABILITY

On standard models, optional above-bed capability allows the platform to rise above the liftgate mainframe for dock loading.



ALL-ALUMINUM MODELS

A corrosion-resistant, lightweight, all-aluminum frame is available for most models.



STANDARD, STEEL-FRAME MODELS FOR 96" WIDE BODIES

ONE-YEAR STANDARD WARRANTY

	Model Number	Load Area	Taper	Travel	Gate Weight
1600 lb. Capacity	Treadplate Platforms				
	89-16 TP37	89 x 37	6	32 - 54	810
	89-16 TP42	89 x 42	6	32 - 54	860
	Aluminum Platforms ¹				
	89-16 EA55	89 x 55	12	32 - 54	715
2000 lb. Capacity	Treadplate Platforms				
	89-20 TP37	89 x 37	6	32 - 54	810
	89-20 TP42	89 x 42	6	32 - 54	860
	Aluminum Platforms ¹				
	89-20 EA55	89 x 55	12	32 - 54	715
	Gas Bottle Rack Platform				
	89-20 GBR	89 x 30	12	32 - 54	805

STANDARD, ALUMINUM-FRAME MODELS FOR 96" WIDE BODIES ²

	Model Number	Load Area	Taper	Travel	Gate Weight
1600 lb. Capacity	Aluminum Platforms ¹				
	A85-16 EA55	85 x 55	12	32 - 54	585
2000 lb. Capacity	Aluminum Platforms ¹				
	A85-20 EA55	85 x 55	12	32 - 54	585

ADDITIONAL BODY SIZES

Body Size	Model	Load Width
80"	73	73
85"	79	79
90"	85	85
102"	95	95





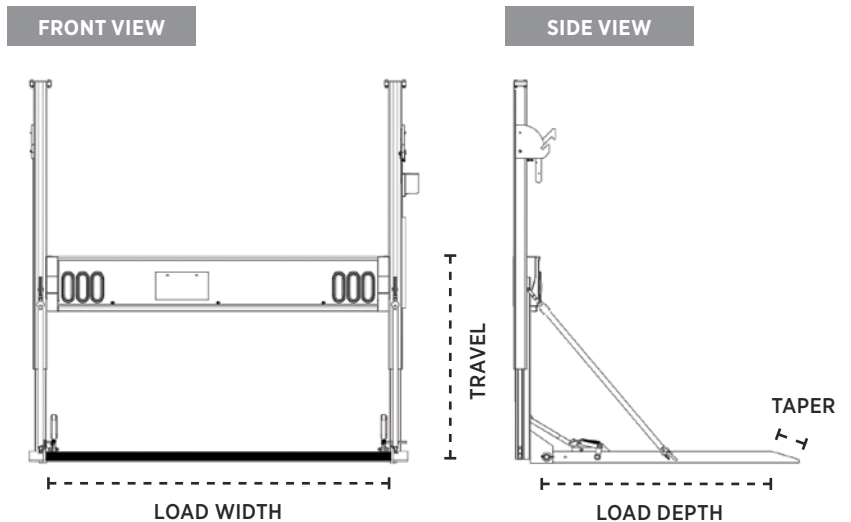

- See additional aluminum platform depths on page 37.
- Aluminum-Frame Standard Railgate models are sized down due to the accompanying bolt-on mounting flanges. Contact factory for more details.
- For detailed dimensions, visit www.tommygate.com

STANDARD RAILGATE DIMENSIONS ³



STANDARD FEATURES

DOCK FRIENDLY MODELS FIXED PLATFORM MODELS







	Recessed Light Kit	●	●
	Safety-trip Bar	●	●
	Self-close System	-	●
	Aluminum Sliders	●	●
	Power Cable with Full-length Ground	●	●
	Circuit Breaker	●	●
	Low-profile Control	●	●

- Standard
- Optional
- Not Available

Every pump and motor that goes into any Tommy Gate hydraulic lift must pass an assembly floor test in addition to quality control inspections by the vendor.

AVAILABLE OPTIONS

DOCK FRIENDLY MODELS FIXED PLATFORM MODELS

	Recessed LED Light Kit	●	●
	Above-bed Travel	●	●
	Dual Controls (w/ pendant)	●	●
	Taper-integrated Cart Stops	●	●
	Split Retention Ramps	-	●
	Rubber Platform Bumpers	●	●
	Auxiliary Battery Box	●	●

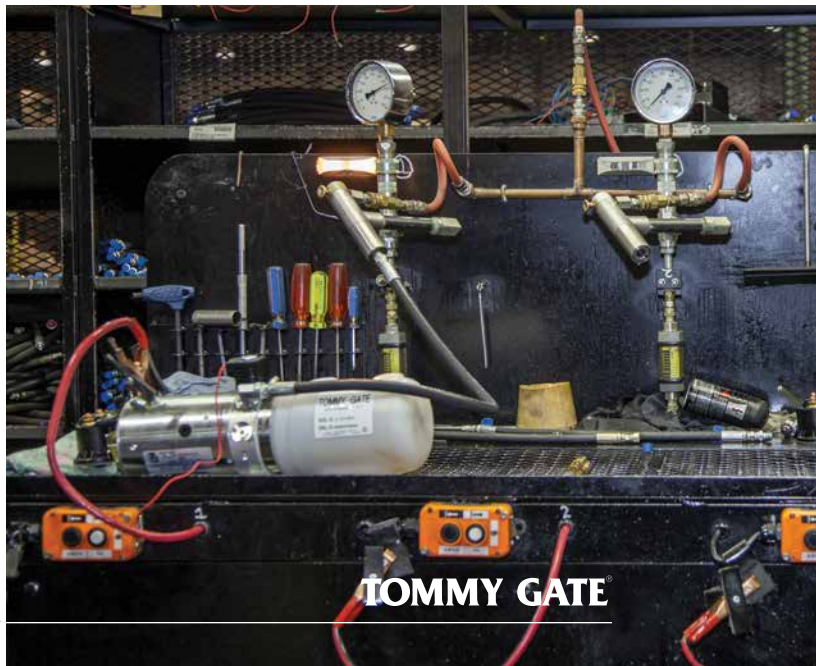

PLATFORM MATERIALS

DOCK FRIENDLY MODELS **FIXED PLATFORM MODELS**

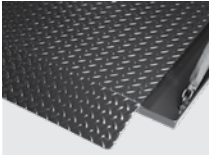
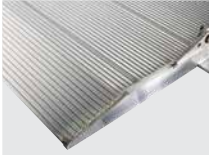
	Steel Treadplate		●
	Extruded Aluminum	●	●

SPLIT CART STOPS

All railgate models with Extruded Aluminum platforms are available with taper-integrated, foot-activated, dual cart stops.



SPLIT RETENTION RAMPS

Steel-platforms (standard models 89 & 85 only) are available with add-on retention ramps.



ALUMINUM PLATFORM DEPTHS

Extruded aluminum platforms (on fixed platform models) are available in any depth, 35”-70”, in 5” increments. Platforms are comprised of interlocking extrusions of 6061-T6 aircraft-quality aluminum.



GAS BOTTLE RACK PLATFORM

GBR - 30” Loading Depth

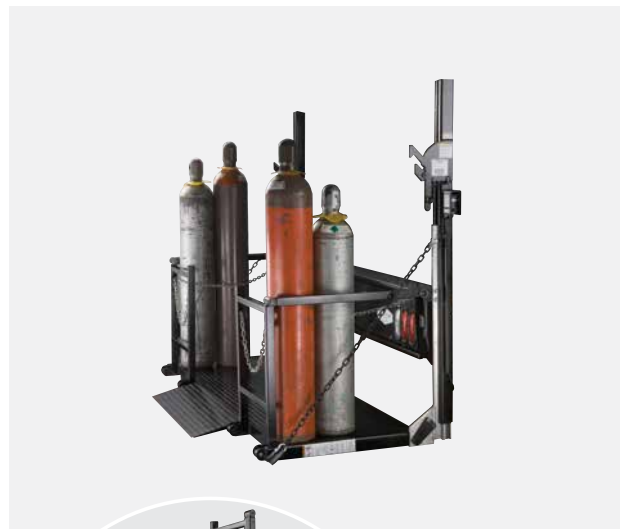



MORE THAN A PICKUP LIFT

The Tommy Gate G2 Series is a dual-cylinder, parallel-arm design which utilizes a pair of hydraulic cylinders to lower and raise the lift by applying direct power to both sides of the platform. Supporting larger platforms, G2 Series models are compatible with flatbed, stake and van bodies and offer a wide selection of platform materials to accommodate almost any industry application.

G2-92-1650 TP41

Shown with discontinued recessed light kit. Recessed lights have been replaced by bolt-on kits.



The G2 Series features only two grease points and the hard-chrome pins are virtually maintenance free.

Hydraulic cylinders are built in-house, precision cylinder welds are executed robotically, and assembly and testing are done by hand.



G2 SERIES LIFTGATE FEATURES

- Dual hydraulic cylinders
- Virtually maintenance-free components
- Recessed control
- Hitch compatibility
- Larger platforms
- Fully-enclosed hydraulic system located within the liftgate mainframe

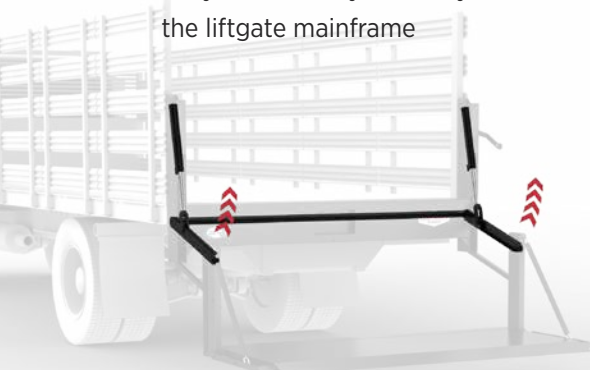

MODELS FOR 96" WIDE BODIES

TWO-YEAR STANDARD WARRANTY

	Model Number	Load Area	Taper	Travel	Platform Fold	Gate Weight
1300 lb. Capacity	Treadplate Platforms					
	G2-92-1350 TP35	87 x 35	6	50	No	628
	G2-92-1350 TP41	87 x 41	6	50	No	655
	TommyTraction™ Platform					
	G2-92-1350 TT33	87 x 33	6	50	No	612
	Aluminum Platforms					
	G2-92-1350 EA37	85 x 37	6	50	No	561
	G2-92-1350 EA41	85 x 41	6	50	No	577
Bar Gate Platform						
G2-92-1350 BG33	87 x 33	6	50	No	637	
1600 lb. Capacity	Treadplate Platforms					
	G2-92-1650 TP35	87 x 35	6	50	No	628
	G2-92-1650 TP41	87 x 41	6	50	No	655
	TommyTraction™ Platform					
	G2-92-1650 TT33	87 x 33	6	50	No	612
	Aluminum Platforms					
	G2-92-1650 EA37	85 x 37	6	50	No	561
	G2-92-1650 EA41	85 x 41	6	50	No	577
Bar Gate Platform						
G2-92-1650 BG33	87 x 33	6	50	No	637	
2000 lb. Capacity	Treadplate Platforms					
	G2-92-2050 TP35	87 x 35	6	50	No	644
	G2-92-2050 TP41	87 x 41	6	50	No	680
	Aluminum Platforms					
	G2-92-2050 EA37	85 x 37	6	50	No	563
G2-92-2050 EA41	85 x 41	6	50	No	577	
LOW-PROFILE MODELS						
1600 lb. Capacity	Treadplate Platforms					
	G2-92-1642 TP38	85 x 38	4	42	YES	609
	Aluminum Platforms					
G2-92-1642 EA38	85 x 38	6	42	YES	523	

ADDITIONAL BODY SIZES

Body Size	Model	Load Width
90"	87	80
85"	81	75
80"	73	66
> 67"	65	60

1. For detailed dimensions, visit www.tommygate.com

G2 SERIES DIMENSIONS ¹

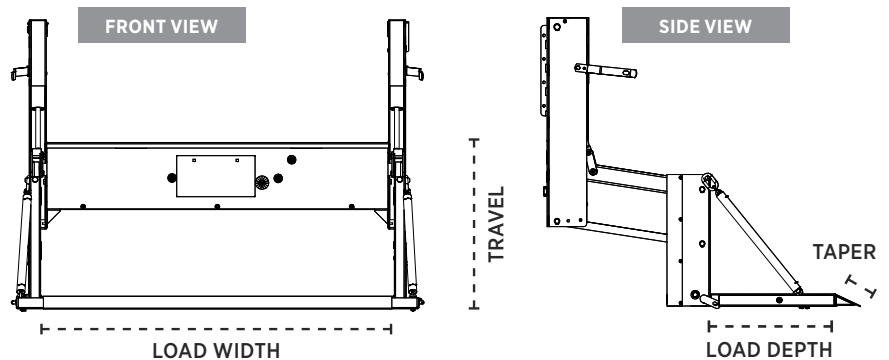

DUMP BODY

G2 SERIES - LIFT-N-DUMP™



1600 LBS CAPACITY



DUMP-THROUGH VERSATILITY

The Tommy Gate G2 Series is a dual-cylinder, parallel-arm design which utilizes a pair of hydraulic cylinders to lower and raise the lift by applying direct power to both sides of the platform. Lift-N-Dump models include all the same features and functions of other G2-Series liftgates, but also offer a unique dump-through capability to be used with dump bodies.

G2-92-1650 LD33

Dual hydraulic cylinders, like all G2 Series models.

Lift-N-Dump models feature pins to lock the platform in place when not in dump-through mode.

Platform latch activates the liftgate's dump-through position.

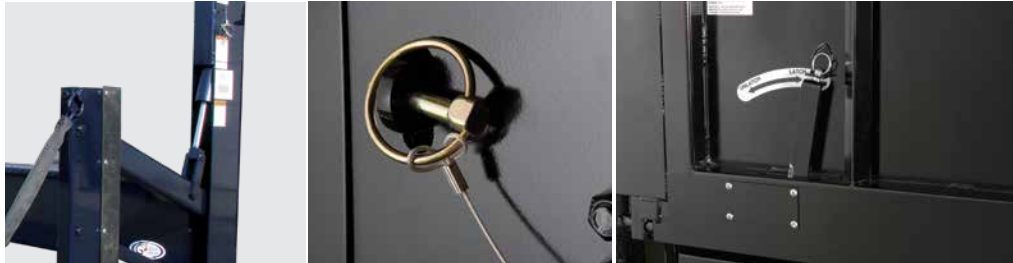

SPECS

MODELS FOR BODIES WITH 83" - 88" WIDE OPENINGS

TWO-YEAR STANDARD WARRANTY

	Model Number	Load Area	Taper	Platform Fold	Travel	Gate Weight
1600 lb. Capacity	Treadplate Platform G2-92-1650 LD33	83 x 33	6	No	50	682

ADDITIONAL BODY SIZES

Body Openings	Model	Load Width
78" - 83"	87	78
69" - 78"	81	73
64" - 69"	73	64





IMPORTANT

Use of a double-acting hoist is recommended. Using a single-acting hoist requires tie-down clamps.







Dimensions similar to Flatbed, Stake, & Van - G2 Series.



STANDARD FEATURES



	Fixed and Timed Toggle Control
	Recessed Control
	Power Cable with Full-length Ground
	150-amp Circuit Breaker
	Maintenance-free Pins and Bushings
	Hitch Compatible ¹

AVAILABLE OPTIONS

	Remote Pendant Control
	Dual Controls
	Rubber Platform Bumpers
	Bolt-on, 3-Light, LED Light Kit
	Bolt-on, 2-Light, LED Light Kit
	Folding Tire Rack ²
	Galvanized Frame and Platform ³

1. Compatible with many hitches.
2. Not available for Lift-N-Dump models.
3. Galvanized option not available with Steel Treadplate platforms or for Lift-N-Dump models. Call factory for ordering details.

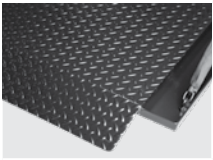
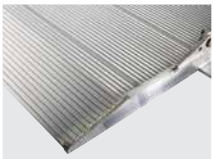
PLATFORM MATERIALS

	Steel Treadplate
	Extruded Aluminum
	TommyTraction
	Steel Bargrate

DROP-CHAIN COVERS

Platform drop-chain covers provide a quieter ride.



EXTRUDED ALUMINUM

EA37 - 37" Loading Depth



STEEL PLATFORMS

TP36 - 36" Loading Depth



BG34 - 34" Loading Depth



TT34 - 34" Loading Depth (SHOWN W/ OPTIONAL TIRE RACK)





42"
Today

50"
Today





THE NEW INTERNAL VAN LIFT

The latest in liftgate technology, the V2 Series by Tommy Gate provides the maximum platform loading area while occupying the smallest possible space when stored in the rear of the van. The V2 combines sleek modern engineering with hands-free platform open and close, built-in cart retention ramp, and 1100lbs. of lifting capacity.



V2-56-1140 FA49



V2 SERIES FEATURES

- 1 RETENTION RAMP** Retention ramp easily locks into place to secure wheelbased carts or cargo. Foot or hand activated.
- 2 BRIDGE MOUNT** Aluminum treadplate bridge mounts provide smooth transition for moving cargo to and from lift platform to vehicle bed.
- 3 TWO-FUNCTION CONTROL** Pendant control with raise/lower toggle and secondary platform fold function.
- 4 FLAT-LOADING TAPER** Platform rests flat at ground level, minimizing load angle.



AVAILABLE MODELS

TWO-YEAR STANDARD WARRANTY

Model Number	Load Area	Taper	Travel	Applications	Gate Weight
--------------	-----------	-------	--------	--------------	-------------

1100 lb. Capacity	Framed Aluminum Platforms					
	V2-56-1140 FA34	47 x 34	9	40	B	420
	V2-56-1140 FA49¹	47 x 49	9	40	A	500

- FA49 Models must have the 9" retention ramp/taper engaged when storing the platform on lower roof van models in order to avoid the ramp from making contact with the van frame. See Application Chart below.

APPLICATIONS *

Manufacturer	Model Year	Body Style	Bracket Code	Roof Height		
				Low	Medium	High
Ford	2015 - 2018	TRANSIT®	AF	B	A, B	A, B
Ford	2015 - 2018	TRANSIT® <i>Extended Body</i>	AG	n/a	n/a	A, B
Ram	2015 - 2018	Ram Promaster	AE	A, B	n/a	A, B
Ram	2015 - 2018	Ram Promaster <i>Extended Body</i>	AH	A, B	n/a	A, B
Sprinter®	2007 - 2018	144" WB 2500	AA	A, B	n/a	A, B
		170" WB Non-Extended 2500				
		170" WB Non-Extended 3500				
Sprinter®	2007 - 2018	170" WB Extended 3500	AA	n/a	n/a	A, B
Sprinter®	2007 - 2018	144" WB 3500	AB	A, B	n/a	A, B
Chevrolet / GMC	2015 - 2018	EXPRESS®	AD	B	n/a	n/a
Nissan	2015 - 2018	NV	AC	B	n/a	A, B

*Some applications have specific requirements. Visit www.tommygate.com for more information.

V2 SERIES INSTALLATION DIMENSIONS *

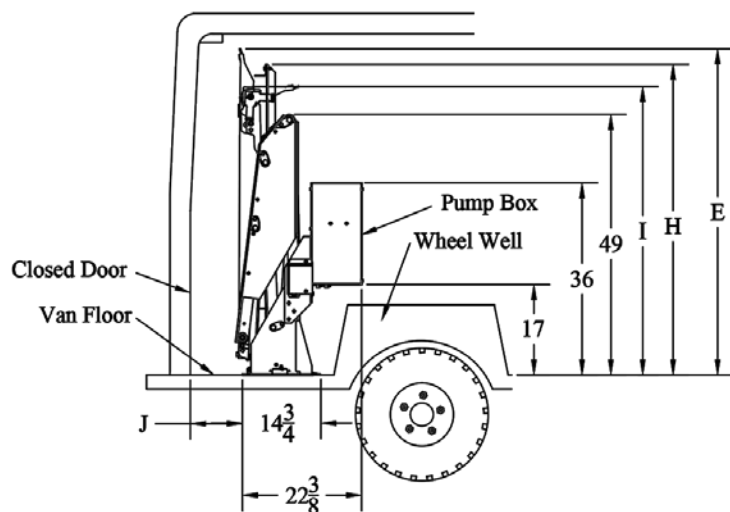

SIDE VIEW

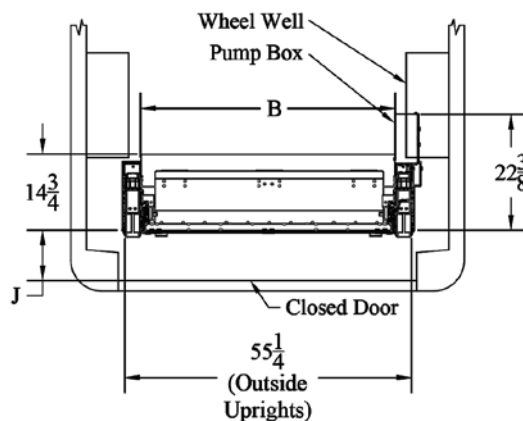

TOP VIEW

*Dimensions E, H, I, & J are all application specific. View the full dimension chart at www.tommygate.com



THE CANTILEVER SERIES

The Tommy Gate Cantilever Series is a modern hydraulic lift that is specifically designed to operate seamlessly with commercial vans.

The culmination of years of engineering, Cantilever Series models are highly versatile and include numerous desirable features. A bolt-on underside mount is compatible with most modern vans and eliminates the need for any welding. The platform is constructed from corrosion-resistant aluminum and folds laterally, allowing for access to the rear of the vehicle without operating the lift. Platforms support a large loadable area and come standard with dual cart stops.

The Cantilever Series features internal bridges, dual cart stops, remote pendant control, and maintenance-free components.



Easy to use and highly efficient, Cantilever Series models are aesthetically pleasing as well as logistically practical.

LEFT: the larger platform (EF71) features 60 inches of loading depth and is recommended for higher-roof vans only.

RIGHT: the smaller platform (EF52) features 40 inches of loading depth and is ideal for low-roof vans.



AVAILABLE MODELS¹

TWO-YEAR STANDARD WARRANTY

Model Number	Load Area	Depth	Travel	Gate Wt.
MB SPRINTER® 2007-2018 2500 All Styles / 3500 170" WB & 170" WB Ext. ²				
CVL-AA-1330 EF71	53 x 60	71	30	610
CVL-AA-1330 EF52	53 x 40	52	30	570
MB SPRINTER® 2007-2018 3500 144" WB ²				
CVL-AB-1330 EF71	53 x 60	71	30	610
CVL-AB-1330 EF52	53 x 40	52	30	570
Nissan NV® 2011-2018				
CVL-AC-1330 EF71	53 x 60	71	30	610
CVL-AC-1330 EF52	53 x 40	52	30	570
Chevrolet / GMC EXPRESS®/SAVANA® 2011-2018				
CVL-AD-1330 EF52	53 x 40	52	30	570
Ram Promaster® 2014-2018 1500/2500/3500, 118", 136", & 159"WB				
CVL-AE-1330 EF71	53 x 60	71	30	610
CVL-AE-1330 EF52	53 x 40	52	30	570
Ram Promaster® 2014-2018 3500, 159"WB Extended Body (ONLY)				
CVL-AH-1330 EF71	53 x 60	71	30	610
CVL-AH-1330 EF52	53 x 40	52	30	570
Ford Transit® 2015-2018 150/250/350, 130", & 148"WB ³				
CVL-AF-1330 EF71	53 x 60	71	30	610
CVL-AF-1330 EF52	53 x 40	52	30	570
Ford Transit® 2015-2018 350, 148"WB Extended Body (ONLY) ³				
CVL-AG-1330 EF71	53 x 60	71	30	610
CVL-AG-1330 EF52	53 x 40	52	30	570

1300 lb. Lifting Capacity

1. Installation may affect specific vehicle features such as rear sensors and back-up cameras. Installation also requires the spare tire to be relocated and is not compatible with any form of towing hitch.
2. Mercedes-Benz requires the use of an auxiliary battery for all liftgates installed on SPRINTER® vans.
3. Ford Transit® "medium-height" models are compatible with EF71 platform. Some Ford Transit® installations may require a separate connection point kit to be ordered from Ford. See Install Instructions or contact customer service.

CANTILEVER SERIES DIMENSIONS

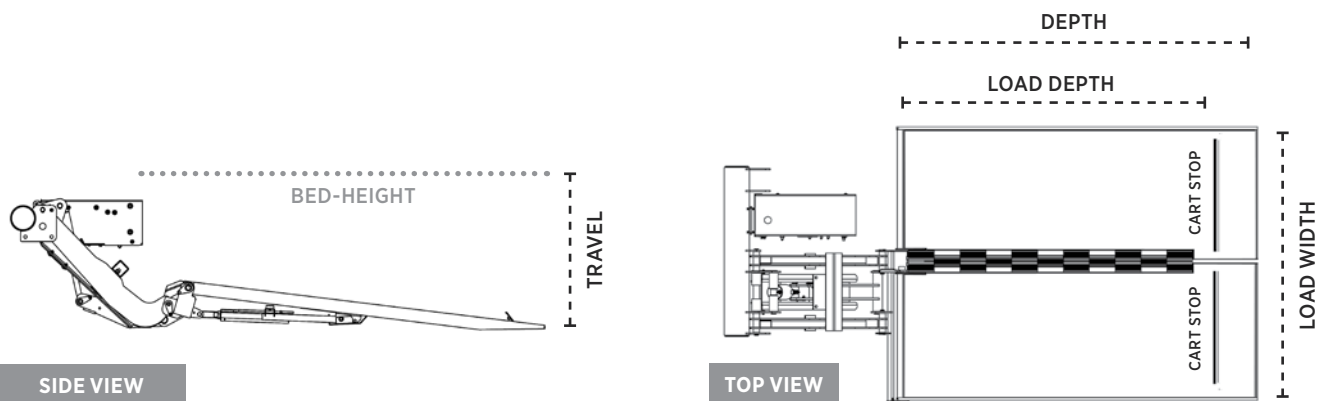

CARGO VAN

650 SERIES



650

650 LBS CAPACITY

THE LIGHT-DUTY INTERNAL VAN LIFT

Low-capacity, compact, and internally-mounted, the 650 Series is the ideal liftgate for lightweight van applications. 650 Series models fold up and store out of the way of ordinary tasks or flat against the inside of the rear door.

Fold-away interior mount offers two secure storage positions and easy access to the rear of the van.



SPECS

AVAILABLE MODELS

ONE-YEAR STANDARD WARRANTY

	Model Number	Load Area	Taper	Travel	Applications ¹	Gate Weight
650 lb. Capacity	Smooth Steel Platform 650	30 x 39	4	31.5	A	345

STANDARD FEATURES

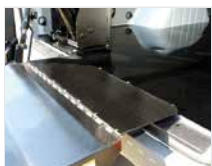

Steel Bridge



Remote Pendant Control

650 SERIES DIMENSIONS

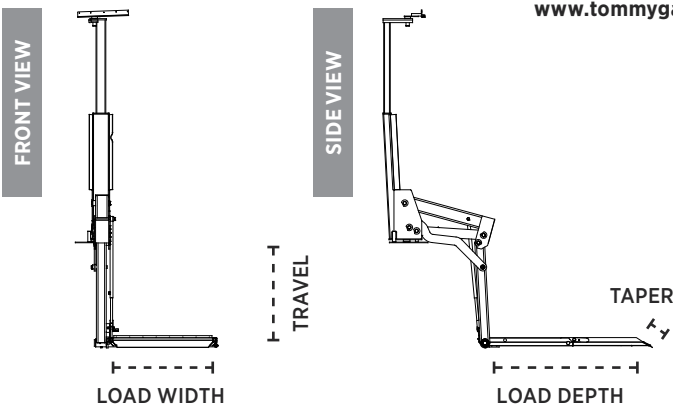

1. See applications on opposite page.
2. For detailed dimensions, visit www.tommygate.com

FULL-SIZE PICKUP LIFTGATES

Code	Manufacturer	Model Year	Body Style	Bracket, Painted	Bracket, Galvanized
A	Chevrolet / GMC	2007-2018	1500	T-170	G-170
B	Chevrolet / GMC	2007-2018	2500	T-170	G-170
B	Chevrolet / GMC	2007-2018	3500	T-170	G-170
A	Chevrolet / GMC	2007	1500 Classic	T-160	G-160
B	Chevrolet / GMC	2007	2500 Classic	T-160	G-160
B	Chevrolet / GMC	2007	3500 Classic	T-160	G-160
A	Chevrolet / GMC	2002-2006	1500	T-160	G-160
B	Chevrolet / GMC	2002-2006	2500	T-160	G-160
B	Chevrolet / GMC	2002-2006	3500	T-160	G-160
A	Dodge / Ram	2002-2018	1500	T-330	G-330
B	Dodge / Ram	2003-2018	2500	T-330	G-330
B	Dodge / Ram	2003-2018	3500 (does not include 2013-2016 DRW)	T-330	G-330
B	Dodge / Ram	2013-2016	3500 (Dual Rear Wheel models only)	T-340	G-340
A	Ford	2002-2014	F-150 ²	T-250	G-250
A	Ford	2015-2018	F-150	T-270	G-270
B	Ford	2002-2016	F-250	T-260	G-260
B	Ford	2002-2016	F-350	T-260	G-260
B	Ford	2017-2018	F-250 / F-350 / F-450	T-285	G-285
A	Nissan	2004-2015	TITAN® ²	T-420	G-420
A	Toyota	2007-2018	TUNDRA®	T-500	G-500

CARGO VAN - 650 SERIES LIFTGATES

Code	Manufacturer	Model Year	Body Style	Bracket
A	Chevrolet / GMC	2002-2005	ASTRO® / SAFARI®	2400
A	Chevrolet / GMC	2002-2018	EXPRESS® / SAVANA®	2410
A	Chevrolet / GMC	2015-2018	CITY EXPRESS®	13319
A	Dodge/Ram	2014-2018	Ram Promaster (standard roof)	13080
A	Dodge/Ram	2014-2018	Ram Promaster (high roof)	13498
A	Dodge/Ram	2015-2018	Promaster City	14502
A	Ford	2002-2014	E-Series	2408
A	Ford	2010-2013	Transit Connect®	10179
A	Ford	2014-2018 ¹	Transit Connect® ³	13694
A	Ford	2015-2018	Transit (standard roof)	13821
A	Ford	2015-2018	Transit (medium roof)	14012
A	Ford	2015-2018	Transit (high roof)	13914
A	SPRINTER®	2002-2006	Standard Roof	2397
A	SPRINTER®	2002-2006	High Roof	2398
A	SPRINTER®	2007-2018	Standard Roof	2632
A	SPRINTER®	2007-2018	High Roof	2633
A	NISSAN	2013-2018	NV200	13319

COMPACT PICKUP LIFTGATES

Tommy Gate Original Series liftgates fit many compact pickup trucks, not shown above. Visit www.tommygate.com to learn more about model “MINI” liftgates.

1. Last 16 model years shown. For additional applications, visit www.tommygate.com
2. Requires special liftgate. Specify when ordering.
3. 650 can not store against inside wheel well on this application.





TOMMY GATE: YESTERDAY AND TODAY

Woodbine Manufacturing Company was founded in 1965, in Woodbine, Iowa by Delbert “Bus” Brown. Working alone, Bus designed and constructed the original Tommy Lift, which he named after his son.

Early stories often recount Bus loading his pickup trailer with up to five liftgates at a time and driving off into the neighboring counties (where he would sell and install them himself), only to return once that trailer was empty.

This was Woodbine Manufacturing Company in its earliest days: a grassroots liftgate manufacturer that was created to ease the work of the local farmers.

Today, the Woodbine factory stands at over 200,000 square feet on the same piece of ground where every Tommy Gate liftgate has been manufactured and assembled for over 50 years. It is a state-of-the-art manufacturing plant that embraces a combination of modern technology fused with old-fashioned, hands-on welding and tooling.

Very much alive and well in the twenty-first century, Tommy Gate liftgates are sold by over 1000 distributors in every corner of the world.

Woodbine Manufacturing Company is one-hundred percent family-owned and operated, and has been since its inception. The company takes great pride in the work ethic, history, and traditions of its employees and strives to continue providing jobs and opportunities to the community it calls home.

It is a testament to the spirit of American manufacturing that Tommy Gate began with a single man, in a small, brick machine shop in rural Iowa.

IMPORTANT NOTES

- Trademarks are property of their respective owners.
- Installation may affect specific vehicle features such as rear sensors, back-up cameras, and trailer hitches.
- All measurements in inches and pounds, unless otherwise specified.
- “Gate Weight” equals the approximate installed liftgate weight.
- “Load Area” is the liftgate platform’s flat, loadable area and is given as width x depth.
- Detailed liftgate dimensions are available at www.tommygate.com.

LEGAL

SPECIFICATION CHANGES Woodbine Manufacturing Company, Inc. reserves the right to make changes in manufacturing to comply with current or new engineering specification changes where applicable.

INSTALLATION COMPLIANCE & PROCEDURES Before installing any liftgate, please observe the Vehicle Loading Limitations. These loading limitations are outlined in the Vehicle Owner’s Manual and the Safety Compliance Certification Label located on the driver’s door pillar.

Liftgate installers are to treat vehicles as incomplete and are therefore responsible for vehicle compliance with all local, state, and federal regulations, including but not limited to all lighting Regulations (see FMVSS 108) and all rearview visibility requirements (see FMVSS 111). Installers must also follow the procedures and specifications as detailed in Tommy Gate installation instructions, including ensuring the proper placement of all warning decals.

In view of the responsibility of altered-stage vehicle manufacturers to comply with FMVSS 111, Tommy Gate offers its “Camera and Sensor Bar” as a possible solution. However, it is the sole responsibility of the upfitter/final stage manufacturer to determine if the Tommy Gate Camera and Sensor Bar meets FMVSS 111 and/or any other applicable vehicle certification - and it is not the responsibility of Tommy Gate/Woodbine. Any information made available by Tommy Gate regarding its Camera and Sensor Bar is not intended to be, and shall not be, relied upon as a final determination of compliance with FMVSS 111 and/or any other vehicle certification. Each distributor must, on its own, make each such required determination for each vehicle it offers to a customer.

WARNING Tommy Gate liftgates are industrial products FOR MATERIAL HANDLING ONLY and are not to be used as a personnel or wheelchair lift. For safe handling and operating instructions, visit www.tommygate.com

TOMMY GATE LIFTGATE STANDARD WARRANTY Tommy Gate G2 Series, Tuckunder Series, High-Cycle Railgates Series, V2 Series, and Cantilever Series liftgates have a two (2) year limited warranty from the date of user purchase against faulty material and workmanship. Tommy Gate Original Series, 650 Series, and standard Railgate Series liftgates have a one (1) year limited warranty from date of purchase. Pump and motor units have a two (2) year limited warranty. Normal usage requirements apply. All affected parts must be returned to the factory prepaid, with full credit issued for those found to be defective. Warranty replacement parts will be shipped from the factory prepaid. THERE ARE NO WARRANTIES, EXPRESS OR IMPLIED, INCLUDING THE WARRANTY OF MERCHANTABILITY OR A WARRANTY OF FITNESS FOR A PARTICULAR PURPOSE, EXTENDING BEYOND THAT SET FOR THE ABOVE.

WARRANTY LIMITATIONS, LIMITATIONS ON WOODBINE’S LIABILITY AND INDEMNIFICATION The modification of any Tommy Gate product in any manner not approved by Woodbine Manufacturing Company, Inc. immediately voids all warranties. Woodbine Manufacturing Company, Inc. shall not be held responsible for any damage resulting from the use of a modified Tommy Gate product, or one that was not properly maintained. The maximum liability of Woodbine Manufacturing Company, Inc. resulting from anything it did or did not do with respect to a Tommy Gate product shall be the price paid for that Tommy Gate product. Woodbine Manufacturing Company, Inc. will not be responsible for any loss of profits, goodwill, business opportunity or consequential damages. Recipients accepting shipments of any Tommy Gate product agree to indemnify, defend, protect, and hold Woodbine Manufacturing Company, Inc. harmless from and against any and all losses, damages claims or expenses of whatever form or nature, including attorneys’ fees and other costs of defense that Woodbine Manufacturing Company, Inc. may incur in connection with any acts or omissions related to the use or misuse of a Tommy Gate product and/or the unauthorized modification of a Tommy Gate Product.

TOMMY GATE®



WOODBINE MANUFACTURING COMPANY, INC.

83 Bus Brown Drive
Woodbine, Iowa 51579
www.tommygate.com

TOLL FREE (800) LIFTGATE
MAIN (712) 847-8000
FAX (712) 647-2417



42

36



LAND OF LINCOLN
M 159787
ILLINOIS



FOREST PARK











RON TIRAPELLI FORD

Family owned since 1984 | 815-725-3033 | rontirapelliford.com



ELLI





**A RESOLUTION AUTHORIZING THE EXECUTION OF A LEGAL SERVICES
ENGAGEMENT AGREEMENT WITH THE SONNENSCHN GROUPE, LLC TO
REPRESENT THE VILLAGE OF FOREST PARK WITH RESPECT TO
THE PAYMENT CARD INTERCHANGE FEE AND
MERCHANT DISCOUNT ANTITRUST LITIGATION MATTER**

WHEREAS, the Sonnenschein Groupe, LLC (“Sonnenschein”) has submitted a proposed engagement agreement to the Village of Forest Park (the “Village”) to represent the Village with respect to payment card interchange fee and merchant discount antitrust litigation, MDL 1720.

NOW, THEREFORE, BE IT RESOLVED by the Mayor and Council of the Village of Forest Park, Cook County, Illinois, as follows:

Section 1. The facts and statements contained in the preambles to this Resolution are found to be true and correct and are hereby adopted as part of this Resolution.

Section 2. It is advisable, necessary and in the public interest that the Village enter into the proposed engagement agreement with Sonnenschein, a copy of which is attached hereto marked as Exhibit “A” and made a part hereof (the “Engagement Agreement”), on a contingent fee basis, to represent the Village with respect to payment card interchange fee and merchant discount antitrust litigation, MDL 1720.

Section 3. The corporate authorities of the Village hereby accept the Engagement Agreement, and the Mayor is hereby authorized and directed to execute, on behalf of the Village, the Engagement Agreement, on a contingent fee basis, and any related documents.

Section 4. This Resolution shall be in full force and effect upon its passage, as provided by law.

ADOPTED by the Council of the Village of Forest Park, Cook County, Illinois this 12th day of August, 2024.

AYES: _____
NAYS: _____
ABSENT: _____

APPROVED by me this 12th day of August, 2024.

Rory E. Hoskins, Mayor

ATTESTED and filed in my office,
And published in pamphlet form
This _____ day of August, 2024.

Vanessa Belmonte, Village Clerk

EXHIBIT "A"

ENGAGEMENT AGREEMENT WITH THE SONNENSCHNEIN GROUPE, LLC

**PAYMENT CARD INTERCHANGE FEE AND
MERCHANT ANTITRUST LITIGATION SETTLEMENT¹**

Name: Village of Forest Park

Email Address: lolmsted@forestpark.net

Phone Number: 708-615-6208

1. What is the merchant's full legal name and address?
Village of Forest Park, 517 DesPlaines Avenue, Forest Park, IL 60130
2. What is the merchant's Tax Identification Number ("TIN")?
36-6005875
3. What is the merchant's approximate average yearly volume for combined Visa/MasterCard sales?
Prior to 2020 the approximate average was \$1,707,300.
For the Village's most recent two fiscal years (FY2023 and FY2024), this average is now \$2,364,790
4. Did you receive a notice about the Visa/MasterCard settlement? If yes, please provide a copy.
There is not a record of notice on file

THE SONNENSCHN GROUPE, LLC



DATE August 12, 2024

VIA EMAIL:

Name
Address

Re: *In re Payment Card Interchange Fee and Merchant Discount Antitrust Litigation,*

MDL 1720 Dear Mayor Rory Hoskins:

This Agreement will memorialize the engagement of The Sonnenschein Groupe, LLC (the "Company") to process any claim Village of Forest Park ("Client") may have as a member of the Rule 23(b)(3) Settlement Class pursuant to any settlement or court award in the above-referenced action, which is currently pending in the United States District Court for the Eastern District of New York.

Client represents that it has received Notice of this settlement or that Client is a member of the Rule 23(b)(3) Settlement Class consisting of: All persons, businesses, and other entities that have accepted any Visa-Branded Cards and/or Mastercard-Branded Cards in the United States at any time from January 1, 2004 to January 25, 2019.

Client further represents that it is not a "Dismissed Plaintiff," a merchant that previously settled and dismissed their own lawsuit, as listed on Appendix B to the Class Settlement Agreement, which is available [here](#). Client consents to the Company's verification of its claim. In the event that Client does not have a claim, the retention of the Company is null and void. Client agrees to keep the terms of this engagement confidential.

Scope of Engagement

The Company expects to render the following services for the Client: (1) conferences with Client and other relevant representatives designated; (2) preparation and submission of all claim forms and any documentation required to substantiate Client's claim; and (3) communicating, as necessary, with the Claims Administrator as to Client's claim and any calculation of Client's claim. Client agrees to promptly provide the Company with all documentation needed to substantiate Client's claim pursuant to the court-approved claim form.

The Company will not provide any legal advice and/or opinions. Although the Company may employ individuals that are licensed attorneys, Client understands that this is an agreement for ***non-legal services only*** related to the preparation and submission of Client's claim. The Company does not provide legal services, no attorney-client relationship is being formed, and the attorney-client privilege does not apply.

The Client shall utilize the Company as its Exclusive Claims Processor for this Antitrust Litigation (MDL 1720) and understands that the Company has the right to use a third-party to administer claim processing. Said third-party may include, but is not limited to, the SRC1 Group, for claim filing and processing.

The Company shall consult with and obtain Client's approval regarding any major decisions arising in connection with the above-referenced work or with respect to any of the services rendered by the Company pursuant to this Agreement.

Fees for Services Rendered

In consideration of the services rendered, and to be rendered, pursuant to this Agreement, Client has agreed to pay as fees to the Company twenty-five percent (25%) of any recovery Client obtains from the Settlement Fund. Said recovered funds received as the result of Client's claim will be deposited into a joint escrow trust account operated by the Company and third-party, SRC1 Group, for distribution. All reasonable costs and out-of-pocket expenses necessary to prepare and submit Client's claim, and to provide other services to be rendered pursuant to this Agreement as outlined above, will be advanced by the Company or Its Third-Party Affiliate, 100% of which will be reimbursed to the Company or said Affiliate solely out of any recovery after application of the twenty-five percent contingency fee.

The Company's engagement will conclude when the Claims Administrator makes payment. The Company assumes no responsibility for any associated allocation, distribution, tax or any post-payment issue(s).

Dispute Resolution

Although we do not expect any disputes to arise between the Client and the Company, if a dispute does in fact arise, all parties agree that the exclusive venue for any action arising under or in any way related to this Agreement shall be DuPage County, Illinois. The parties expressly waive any objection or defense that such venue is an inconvenient or otherwise improper forum for any dispute arising under or in any way related to this Agreement. The parties also waive any and all objections to personal jurisdiction as they may relate to the enforcement of the terms of this Agreement in DuPage County, Illinois.

Law Governing this Agreement

This Agreement shall be interpreted and enforced pursuant to the laws of the State of Illinois, both substantive and procedural, regardless of choice of law principles.

Entire Understanding Between Parties

This Agreement represents the entire Agreement between the parties with respect to the engagement of the Company for the Client in this matter. The parties acknowledge that they have not relied upon any representations made by another party or other person as an inducement to enter into this Agreement. Client acknowledges that the Company has made no guarantee as to the outcome of this matter or the amount recoverable in connection with Client's claim. Further, the parties acknowledge that no representations have been made, other than those expressly set forth in this Agreement. No amendment, waiver or modification of any other terms and conditions set forth in this Agreement shall be effective unless in writing, signed by both parties.

If this Agreement accurately reflects the terms of our representation of Client in this matter, please sign and date in the space provided below and e-mail an executed copy of the Agreement to the Company. It is not necessary for class members to sign up for a third-party service to participate in any monetary relief, as no-cost assistance is available from the Class Administrator and Class Counsel during the claims-filing period. For more information, visit Payment Card Settlement I Official Court-Authorized Website - Home. This Agreement may be signed in one or more counterparts, all of which shall be deemed original.

We look forward to working with you in this matter and thank you again for your confidence and trust.

Sincerely,
The Sonnenschein Groupe, LLC

AGREED AND ACCEPTED:

By: _____
CLIENT

DATE

August 12, 2024

Sonnenschein Groupe
Two TransAm Plaza Drive Suite 300
Oakbrook Terrace, Illinois 60181

Per the Village of Forest Park Municipal Code, Chapter 4, the duties of the Mayor include but are not limited to authorized signer as stated:

1-4-3-1: COMMISSIONER OF PUBLIC AFFAIRS:

B: Powers And Duties:

- 3. He shall, on behalf of the village, sign all contracts the execution of which shall have been authorized by the village council.

NAME: Mayor Rory E. Hoskins

SIGNATURE: _____

TITLE: Mayor

RESOLUTION NO. R-_____ -24

**A RESOLUTION APPROVING PAY REQUEST #1 FOR THE 2024 GREEN ALLEY
IMPROVEMENTS PROJECT FROM J. NARDULLI CONCRETE, INC.
(800 & 900 Block of Circle-Marengo Alley)**

WHEREAS, the Village of Forest Park, Cook County, Illinois ("Village"), awarded the contract for the 2024 Green Alley Improvements Project to J. Nardulli Concrete, Inc. ("Contractor"); and

WHEREAS, Contractor has submitted its Pay Request #1 for completion of the work to date under the Project, a copy of which is attached hereto and made a part hereof; and

WHEREAS, the Pay Request #1 has been reviewed by the Village Engineer, who has determined that Contractor is entitled to compensation for its performance under the Project to date, pursuant to the Pay Request #1; and

WHEREAS, the Village will be obligated to make a payment on Pay Request #1 to Contractor in the amount of Three Hundred Forty-One Thousand Six Hundred Six and 35/100 Dollars (\$341,606.35); and

WHEREAS, it is necessary that the Mayor and Council of the Village approve Pay Request #1 to Contractor under the contract for the Project.

NOW, THEREFORE, BE IT RESOLVED, by the Mayor and Council of the Village of Forest Park, Cook County, Illinois, as follows:

Section 1. The Council of the Village hereby approves Pay Request #1 to Contractor in the amount of Three Hundred Forty-One Thousand Six Hundred Six and 35/100 Dollars (\$341,606.35) under the contract for the Project with Contractor.

Section 2. The Village Clerk is directed to attest to the Mayor's signature on any and all documents, as necessary.

Section 3. This Resolution shall be in full force and effect upon its passage in the manner provided by law.

RESOLVED by the Council of the Village of Forest Park, Cook County, Illinois this 12th day of August, 2024.

AYES: _____

NAYS: _____

ABSENT: _____

APPROVED by me this 12th day of August, 2024.

Rory E. Hoskins, Mayor

ATTESTED and filed in my office,
and published in pamphlet form
this _____ day of August, 2024.

Vanessa Belmonte, Village Clerk

2024 GREEN ALLEY IMPROVEMENTS PROJECT
PAY REQUEST #1



CHRISTOPHER B. BURKE ENGINEERING, LTD.
 9575 W Higgins Road, Suite 600 Rosemont, Illinois 60018-4920 Tel (847) 823-0500 Fax (847) 823-0520

July 12, 2024

Village of Forest Park
 Department of Public Works
 7343 W. 15th Street
 Forest Park, IL 60130

Attention: Salvatore Stella
 Director of Public Works

Subject: 2024 Green Alley Improvements – 800 & 900 block of Circle-Marengo Alley
 Pay Request #1
 (CBBEL Project No. R000023.BG113)

Dear Mr. Stella:

Christopher B. Burke Engineering, Ltd. (CBBEL) has reviewed Pay Request #1 submitted by J. Nardulli Concrete, Inc. in the amount of **\$341,606.35** for the work completed so far. The payment will be:

1.	Contract Amount	\$	735,388.25
2.	Work Completed to Date	\$	379,562.61
3.	Less Previous Payments	\$	0.00
4.	Less Retainage (10%)	\$	<u>37,956.26</u>
5.	Amount Due	\$	341,606.35

We recommend payment in the amount of **\$341,606.35** to J. Nardulli Concrete, Inc.

Please find enclosed the invoice, partial waivers of lien and certified payrolls. If you have any questions or concerns, please contact me at (224) 275-0030.

Sincerely,

Brad S. Bahn
 Construction Engineer

J NARDULLI CONCRETE, INC.

PCC Pavement • Curb & Gutter • Sidewalks & Driveways

INVOICE

DATE	CUSTOMER #	NUMBER
7/12/2024		20240712

BILL TO
Village Of Forest Park
517 Desplaines Ave Forest Park IL 60130

RE:
Village of Forest Park
2024 Green Alley Project PE#1

Item No.	Description	Unit	Quantity	Unit Price	Amount
1	TREE TRUNK PROTECTION	EACH	0	\$ 400.00	\$ -
2	TREEN ROOT PRUNING	EACH	0	\$ 800.00	\$ -
3	EARTH EXCAVATION	CU YD	1200	\$ 47.25	\$ 56,700.00
4	REMOVAL & DISPOSAL OF UNSUITABLE MATERIAL	CU YD	0	\$ 47.25	\$ -
5	POUROUS GRANULAR EMBANKMENT	CU YD	0	\$ 41.50	\$ -
6	INLET FILTERS	EACH	2	\$ 150.00	\$ 300.00
7	PCC PAVEMENT 8 INCH	SQ YD	735.78	\$ 97.25	\$ 71,554.61
8	PCC SIDEWALK 5 INCH	SQ FT	0	\$ 9.00	\$ -
9	SIDEWALK REMOVAL	SQ FT	0	\$ 2.00	\$ -
10	PAVEMENT REMOVAL(SPECIAL)	SQ YD	1600	\$ 15.00	\$ 24,000.00
11	CLASS D PATCHES TYPE IV 8"	SQ YD	0	\$ 83.50	\$ -
12	STORM SEWER REMOVAL 8	FOOT	0	\$ 5.00	\$ -
13	STORM SEWER INSTALLATION 8	FOOT	0	\$ 30.00	\$ -
14	PIPE UNDERDRAINS TYPE 2, 4"	FOOT	0	\$ 20.00	\$ -
15	CATCH BASINS TY A , 4 DIA TY 1 FRAME, OPEN LID	EACH	3	\$ 7,500.00	\$ 22,500.00
16	INLETS , TY A , TY 1 FRAME OPEM LID	EACH	2	\$ 3,200.00	\$ 6,400.00
17	TRAFFIC CONTROL & PROTECTION	L SUM	0.5	\$ 25,000.00	\$ 12,500.00
18	SIGN PANEL TYPE 1	SQ FT	0	\$ 22.00	\$ -
19	TELESCOPING STEEL SIGN SUPPORT	FOOT	0	\$ 21.00	\$ -
20	METAL POST TYPE A	FOOT	0	\$ 15.00	\$ -
21	WASHOUT BASIN	L SUM	1	\$ 1,500.00	\$ 1,500.00
22	PRECONSTRUCTION VIDEO TAPING	L SUM	1	\$ 800.00	\$ 800.00
23	AGGREGATE FOR TEMPORARY ACCESS	TON	0	\$ 25.00	\$ -
24	CONSTRUCTION LAYOUT	L SUM	1	\$ 3,500.00	\$ 3,500.00
25	TRENCH BACKFILL SPECIAL (WASHED CA-7)	CU YD	650	\$ 55.00	\$ 35,750.00
26	PCC DRIVEWAY REMOVAL & REPLACEMENT 8"	SQ YD	300	\$ 97.00	\$ 29,100.00
27	HMA DRIVEWAY REMOVAL & REPLACEMENT	SQ YD	50	\$ 67.50	\$ 3,375.00
28	COMBINATION CURB & GUTTER REMOVAL & REPLACEMENT	FOOT	100	\$ 50.00	\$ 5,000.00
29	DETECTABLE WARNINGS	EACH	0	\$ 350.00	\$ -
30	STORM SEWERS 12" SPECIAL	FOOT	1016	\$ 85.00	\$ 86,360.00
31	CORED CONNECTION TO STRUCTURE/SEWER	EACH	1	\$ 3,000.00	\$ 3,000.00
32	STRUCTURE TO BE ADJUSTED	EACH	1	\$ 1,200.00	\$ 1,200.00
33	EDGE SLOPE ADJUSTMENT	FOOT	97	\$ 9.00	\$ 873.00
34	PERMEABLE CONCRETE PAVERS	SQ FT	0	27.25	0
35	TIDFLEX CHECKMATE INLINE CHECK VALVE 12"	EACH	1	\$ 3,500.00	3500
36	HALF TRAP	EACH	1	\$ 250.00	250
37	ITEMS ORDERED BY ENGINEER	DOLLAR	5000	\$ 1.00	5000
38	TENSAR TRIAX 130S GEOGRID	SQ YD	1600	\$ 4.00	6400

TOTAL UP TO DATE	\$ 379,562.61
Less 10% Retained	\$ 37,956.26
Subtotal	\$ 341,606.35
Less Previous Payment	\$ -
Total Pay Est 1 DUE	\$ 341,606.35

J. NARDULLI CONCRETE, INC. • 3517 S. 60th Ct. • Cicero, IL 60804 • Phone: (708) 652-3000 • Fax: (708) 652-3006

STATE OF ILLINOIS
COUNTY OF COOK

WAIVER OF LIEN TO DATE

To Whom It May Concern:

WHEREAS the undersigned has been employed by VILLAGE OF FOREST PARK to furnish labor and material for **CONCRETE CONSTRUCTION** work for the project known as 2024 GREEN ALLEY PROJECT of which VILLAGE OF FOREST PARK is the owner.

The undersigned, for and in consideration of THREE HUNDRED FORTY ONE THOUSAND SIX HUNDRED SIX 35/100 (\$341,606.35) Dollars, and other good and valuable considerations, the receipt whereof is hereby acknowledged, do (es) hereby waive and release any and all lien or claim of, or right to, lien, under the statutes of the State of Illinois, relating to mechanics' liens, ADDITIONALLY, the undersigned hereby waives and releases any and all of the undersigned's rights and claims under the Illinois Public Construction Bond Act to the same extent the undersigned waives and releases any and all lien or claim of, or right to lien under the statutes of Illinois relating to mechanics liens, with respect to and on said above-described premises, and the improvements thereon, and on the material, fixtures, apparatus or machinery furnished, and on the moneys, funds or other considerations due or to become due from the owner, on account of all labor, service, material, fixtures, apparatus or machinery, or which may be furnished at any time hereafter, by the undersigned for the above-described premises, INCLUDING EXTRAS*

DATE July 12, 2024

Company Name: J. NARDULLI CONCRETE, INC.
Address: 3517 S. 60th CT., CICERO, ILLINOIS 60804

SIGNATURE AND TITLE *Jose A Gaucin* PRESIDENT

*EXTRAS INCLUDE BUT ARE NOT LIMITED TO CHANGE ORDERS, BOTH ORAL AND WRITTEN, TO THE CONTRACT.

STATE OF ILLINOIS
COUNTY OF COOK
CONTRACTOR'S AFFIDAVIT

To Whom It May Concern:

THE UNDERSIGNED, JOSE A. GAUCIN BEING DULY SWORN, DEPOSES AND SAYS THAT HE OR SHE IS **PRESIDENT OF J. NARDULLI CONCRETE, INC.** WHO IS THE CONTRACTOR FURNISHING LABOR AND EQUIPMENT FOR **CONCRETE CONSTRUCTION** WORK ON THE PROJECT KNOWN AS 2024 GREEN ALLEY PROJECT OWNED BY VILLAGE OF FOREST PARK.

That the total amount of the contract including extras* \$ 735,388.25, on which he or she has received payment of \$ 0.00 prior to this payment. That all waivers are true, correct and genuine and delivered unconditionally and that there is no claim either legal or equitable to defeat the validity of said waivers, That the following are the names and addresses of all parties who have furnished material or labor, or both, for said work and all parties having contracts or sub contracts for specific portions of said work or for material entering into the construction thereof and the amount due or to become due to each, and that the items mentioned include all labor and material required to complete said work according to plans and specifications:

NAMES	WHAT FOR	CONTRACT PRICE INCL. EXTRAS*	AMOUNT PAID	THIS PAYMENT	BALANCE DUE
J. NARDULLI CONCRETE, INC.	LBR.PR.F.OH.EQP.	\$365,638.25	\$0	\$219,561.85	\$ 146,076.40
ELMHURST CHICAGO STONE	READYMIX	\$73,575.00	\$0	\$0	\$ 73,575.00
UNO CONSTRUCTION INC	UNDERGROUND	\$191,925.00	\$0	\$122,044.50	\$ 69,880.50
CR SCHMIDT	PAVERS	\$82,775.00	\$0	\$0	\$ 82,775.00
HEIDELBERG MATERIALS	AGGREGATES	\$21,475.00	\$0	\$0	\$21,475.00
TOTAL LABOR & MATERIAL INCLUDING EXTRAS* TO COMPLETE		\$735,388.25	\$0	\$341,606.35	\$ 393,781.90

That there are no other contracts for said work outstanding, and that there is nothing due or to become due to any person for material, labor or other work of any kind done or to be done upon or in connection with said work other than above stated.

DATE 07/12/2024 Signature: *Jose A Gaucin*

SUBSCRIBED AND SWORN TO BEFORE ME THIS 07/12/2024 *Marco Arellano*
NOTARY PUBLIC

*EXTRAS INCLUDE BUT ARE NOT LIMITED TO CHANGE ORDERS, BOTH ORAL AND WRITTEN, TO THE CONTRACT.

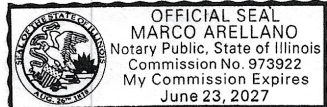

**Waiver of Lien to Date
(Partial)**

State of Illinois }
County DuPage } ss.

ESCROW # _____

To Whom It May Concern:

WHEREAS the undersigned has been employed by J. Nardulli Concrete
to furnish Undeground Sewer Work
for the premises known as 2024 Green Alley Improvements
of which Village of Forest Park is the owner.

The undersigned, for and in consideration of One Hundred Twenty Two Thousand Forty Four and 50/100
(\$ 122,044.50) Dollars, and other good and valuable consideration, the receipt whereof is hereby acknowledged,
do(es) hereby waive and release any and all lien or claim of, or right to lien, under the statutes of the State of Illinois, relating
to mechanics' liens, with respect to and on said above-described premises, and the improvements thereon, and on the material,
fixtures, apparatus or machinery furnished, and on the monies, funds or other considerations due or to become due from the
owner, on account of labor services, material, fixtures, apparatus or machinery, furnished to this date by the undersigned for
the above-described premises.

Date 07/11/24 Company Name Uno Construction Co. Inc.

Signature and Title _____ Address 6037 Brookbank Rd. Downers Grove, IL 60516
Albert Garcia President

CONTRACTOR'S AFFIDAVIT

State of Illinois }
County DuPage } ss.

To Whom It May Concern:

The undersigned, (Name) Alberto Garcia being
duly sworn, deposes and says that he or she is (Position/Title) President
of (Company Name) Uno Construction Co. Inc.
who is the contractor furnishing Underground Sewer Work
work on the building located at 2024 Green Alley Improvements

owned by Village of Forest Park that the total amount of the contract including extras
is \$ 191,925.00 on which he or she has received payment of
(CONTRACT AMOUNT)

\$ 0.00 prior to this payment. That all waivers are
(PREVIOUS PAYMENT)

true, correct and genuine and delivered unconditionally and that there is no claim either legal or equitable to defeat the
validity of said waivers. That the following are the names of all parties who have furnished material or labor, or both, for said
work and all parties having contracts or sub contracts for specific portions of said work or for material entering into the
construction thereof and the amount due or to become due to each, and that the items mentioned include all labor and material
required to complete said work according to plans and specification:

SUPPLIER INFORMATION & MATERIAL WAIVER

NAME/ADDRESSES	WHAT FOR	CONTRACT PRICE	PREVIOUS PAYMENT	THIS PAYMENT	BALANCE TO BECOME DUE
<u>Uno Construction Co. Inc.</u>	<u>Underground</u>	<u>191,925.00</u>	<u>0.00</u>	<u>122,044.50</u>	<u>69,880.50</u>
<u>6037 Brookbank Rd.</u>					
<u>Downers Grove, IL 60516</u>					
TOTAL LABOR AND MATERIAL TO COMPLETE		\$191,925.00	\$0.00	\$122,044.50	\$69,880.50

That there are no other contracts for said work outstanding, and that there is nothing due or to become due to any person for material, labor or other work of any kind done or to be done upon or in connection with said work other than above stated.

Date 7-11-24 Signature _____

Subscribed and sworn to before me this 11th day of July, 2024

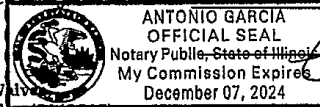

Notary Public

Construction, Partial Lien Waiver
Stewart Title - Illinois Division (07/2020)

Certified Payroll Report

Contractor J. NARDULLI CONCRETE, INC.
 3517 SOUTH 60TH CT.
 CICERO, IL 60804
 Tax ID 38-4095306

Project Village of Forest Park 2024 Green Alley Improvements

Project/Contract #
 Payroll Number 1
 For Week Ending 7/6/24

Employee Name	ID	Work Classification	Pay Type	Hours Worked by Day							Timesheet Hours	Paid Hours	Pay Rate	Job Gross Pay	Fringe Rate	Check Number	Total Gross Pay	Social Security	Medi-care	Federal Tax	State Tax	Other	Total Deduct	Net Pay
				Sun	Mon	Tue	Wed	Thu	Fri	Sat														
	9835	Wages	RT					8.00		8.00	8.00	50.15	401.20	0.00	15200	1,755.26	108.82	25.46	125.00	78.96	65.82	404.06	1,351.20	
	9438	Wages	RT					8.00		8.00	50.15	401.20	0.00	15201	1,642.42	101.83	23.81	131.00	76.02	61.59	394.25	1,248.17		
	1136	Wages	RT	8.00	8.00	8.00	8.00	32.00		32.00	57.80	2,196.40	2.00	15218	2,196.40	136.18	31.85	197.00	103.44	372.99	841.46	1,426.94		
		OT		1.00	1.00	1.00	1.00	4.00		4.00	86.70													
	4067	Wages	RT	8.00	8.00	8.00		24.00		24.00	50.15	1,203.60	0.00	15202	1,203.60	74.63	17.45	68.00	59.58	45.14	264.80	938.80		
	3054	Wages	RT				8.00	8.00		16.00	50.15	802.40	0.00	15198	2,006.00	124.38	29.08	145.00	99.30	75.23	472.99	1,533.01		
	2974	Wages	RT					8.00		8.00	50.15	401.20	0.00	15207	401.20	24.87	5.82	1.00	17.22	15.05	63.96	337.24		
	4424	Wages	RT					8.00		8.00	52.00	416.00	0.00	15208	1,742.00	108.01	25.26	245.00	83.59	65.33	527.19	1,214.81		
	8796	Wages	RT					8.00		8.00	52.00	416.00	0.00	15193	1,768.00	109.62	25.64	166.00	87.52	498.59	987.37	880.63		
	3889	Wages	RT	8.00	8.00	8.00	8.00	32.00		32.00	50.15	1,642.42	0.00	15209	1,642.42	101.83	23.81	121.00	81.30	61.59	389.53	1,252.89		
		OT				0.50		0.50		0.50	75.24													
	1071	Wages	RT					8.00		8.00	50.15	401.20	0.00	15210	1,642.42	101.83	23.82	141.00	76.75	61.59	404.99	1,237.43		
	2630	Wages	RT					8.00		8.00	52.40	458.50	0.00	15213	1,873.30	116.14	27.17	158.00	87.45	70.25	459.01	1,414.29		
		OT						0.50		0.50	78.60													
	5546	Wages	RT					8.00		8.00	50.15	401.20	0.00	15215	1,680.03	104.16	24.37	145.00	80.52	63.00	417.05	1,262.98		
	7564	Wages	RT					8.00		8.00	50.15	438.82	0.00	15217	1,755.27	108.82	25.46	124.00	76.32	65.82	400.42	1,354.85		
		OT						0.50		0.50	75.24													

Employee

	Ttl Hours	Avg Rate	Gross Pay	Fringe Amt	Accrued Sick Hrs	Accrued Vac Hrs							
Classification	34.00	51.63	1,755.26	0.00	0.00	0.00							
Wages	8.00	50.15	401.20	0.00	0.00	0.00	0.00	0.00	0.00	0.00	0.00	0.00	50.15
Classification	32.50	50.54	1,642.42	0.00	0.00	0.00							
Wages	8.00	50.15	401.20	0.00	0.00	0.00	0.00	0.00	0.00	0.00	0.00	0.00	50.15
Classification	36.00	61.01	2,196.40	72.00	0.00	0.00							
Wages	36.00	57.80	2,196.40	72.00	0.00	0.00	0.00	0.00	72.00	2.00	0.00	0.00	59.80
Classification	24.00	50.15	1,203.60	0.00	0.00	0.00							
Wages	24.00	50.15	1,203.60	0.00	0.00	0.00	0.00	0.00	0.00	0.00	0.00	0.00	50.15
Classification	40.00	50.15	2,006.00	0.00	0.00	0.00							
Wages	16.00	50.15	802.40	0.00	0.00	0.00	0.00	0.00	0.00	0.00	0.00	0.00	50.15
Classification	8.00	50.15	401.20	0.00	0.00	0.00							
Wages	8.00	50.15	401.20	0.00	0.00	0.00	0.00	0.00	0.00	0.00	0.00	0.00	50.15
Classification	33.00	52.79	1,742.00	0.00	0.00	0.00							
Wages	8.00	52.00	416.00	0.00	0.00	0.00	0.00	0.00	0.00	0.00	0.00	0.00	52.00
Classification	33.00	53.58	1,768.00	0.00	0.00	0.00							
Wages	8.00	52.00	416.00	0.00	0.00	0.00	0.00	0.00	0.00	0.00	0.00	0.00	52.00
Classification	32.50	50.54	1,642.42	0.00	0.00	0.00							
Wages	8.00	50.15	401.20	0.00	0.00	0.00	0.00	0.00	0.00	0.00	0.00	0.00	50.15
Classification	32.50	50.54	1,642.42	0.00	0.00	0.00							
Wages	8.00	50.15	401.20	0.00	0.00	0.00	0.00	0.00	0.00	0.00	0.00	0.00	50.15
Classification	34.50	54.30	1,873.30	0.00	0.00	0.00							

Classification	Hours	Rate	Gross Pay	Fringe Amt	Accrued Sick Hrs	Accrued Vac Hrs	Accrued Sick	Accrued Vac	Ttl Fringe	Fringe Rate	Total Rate
Wages	8.50	52.40	458.50	0.00	0.00	0.00	0.00	0.00	0.00	0.00	52.40
Employee											
Ttl Hours Avg Rate Gross Pay Fringe Amt Accrued Sick Hrs Accrued Vac Hrs											
	33.00	50.91	1,680.03	0.00	0.00	0.00					
Classification	Hours	Rate	Gross Pay	Fringe Amt	Accrued Sick Hrs	Accrued Vac Hrs	Accrued Sick	Accrued Vac	Ttl Fringe	Fringe Rate	Total Rate
Wages	8.00	50.15	401.20	0.00	0.00	0.00	0.00	0.00	0.00	0.00	50.15
Ttl Hours Avg Rate Gross Pay Fringe Amt Accrued Sick Hrs Accrued Vac Hrs											
	34.00	51.63	1,755.27	0.00	0.00	0.00					
Classification	Hours	Rate	Gross Pay	Fringe Amt	Accrued Sick Hrs	Accrued Vac Hrs	Accrued Sick	Accrued Vac	Ttl Fringe	Fringe Rate	Total Rate
Wages	8.50	50.15	438.92	0.00	0.00	0.00	0.00	0.00	0.00	0.00	50.15

Certified Payroll Report

Contractor	UND CONSTRUCTION CO., INC. 6037 BROOKBANK RD DOWNERS GROVE, IL 06516-1849	Project	Forest ParkGreen Alley	Project/Contract #	1
Tax ID	38-3495154	Payroll Number		For Week Ending	6/22/2024

Employee Name	SSN	Work Classification	Pay Type	Hours Worked by Day							Timesheet Hours	Paid Hours	Pay Rate	Job Gross Pay	Fringe Rate	Check Number	Total Gross Pay	Social Security	Medicare	Federal Tax	State Tax	Other	Total	
				Sun 16	Mon 17	Tue 18	Wed 19	Thu 20	Fri 21	Sat 22													Deduct	Net Pay
		Wages	RT	8.00	8.00	8.00	8.00	8.00			40.00	50.15	2,006.00	0.00	12070	2,006.00	124.37	29.09	145.00	86.09	75.23	459.78	1,546.22	
		Wages - (Loc150)	RT	8.00	8.00	8.00	8.00	8.00			40.00	62.00	2,480.00	0.00	12071	4,403.00	272.98	63.85	655.00	217.95	1,251.75	2,461.53	1,941.47	
		Wages	RT	8.00	8.00	8.00	8.00	8.00			40.00	50.15	2,006.00	0.00	12075	2,006.00	124.37	29.09	154.00	99.30	75.23	481.99	1,524.01	
		Wages	RT					8.00			8.00	50.15	401.20	0.00	12076	2,006.00	124.37	29.09	321.00	91.37	75.23	641.06	1,364.94	
		Wages	RT				8.00	8.00			16.00	50.15	802.40	0.00	12077	2,006.00	124.37	29.09	126.00	94.01	75.23	448.70	1,557.30	

Certified Payroll Report

Contractor UNO CONSTRUCTION CO., INC.
 8337 BROOKBANK RD
 DOWNERS GROVE, IL 06516-1849
 Tax ID 36-3495154

Project Forest Park:Green Alley

Project/Contract #
 Payroll Number 2
 For Week Ending 6/29/2024

Employee Name	SSN	Work Classification	Pay Type	Hours Worked by Day							Timesheet Hours	Paid Hours	Pay Rate	Job Gross Pay	Fringe Rate	Check Number	Total Gross Pay	Social Security	Medicare	Federal Tax	State Tax	Other	Total Deduct	Net Pay
				Sun 23	Mon 24	Tue 25	Wed 26	Thu 27	Fri 28	Sat 29														
		Vages	RT	8.00	8.00	8.00	8.00	8.00			40.00	50.15	2,006.00	0.00	12078	2,006.00	124.37	29.08	145.00	86.09	75.23	459.77	1,546.23	
		Vages - (Loc150)	RT	8.00	8.00	8.00	8.00	8.00			40.00	66.20	2,648.00	0.00	12079	5,209.40	322.99	75.53	848.00	257.87	1,251.75	2,756.14	2,453.26	
		Vages	RT	8.00		8.00	8.00				24.00	50.15	1,203.60	0.00	12080	2,006.00	124.37	29.09	321.00	99.30	75.23	648.99	1,357.01	
		Vages	RT	8.00	8.00	8.00	8.00	8.00			40.00	50.15	2,006.00	0.00	12084	2,006.00	124.38	29.09	154.00	99.30	75.23	482.00	1,524.00	
		Vages	RT	8.00		8.00	8.00				24.00	50.15	1,203.60	0.00	12085	2,006.00	124.37	29.08	321.00	91.37	75.23	641.05	1,364.95	
		Vages	RT	8.00		8.00	8.00				24.00	50.15	1,203.60	0.00	12086	2,006.00	124.38	29.09	126.00	94.01	75.23	448.71	1,557.29	

RESOLUTION NO. R-_____ -24

**A RESOLUTION AUTHORIZING ACCEPTANCE AND EXECUTION OF AN
ILLINOIS DEPARTMENT OF TRANSPORTATION SUSTAINED TRAFFIC
ENFORCEMENT PROGRAM (STEP) FOR HIGH VISIBILITY
ENFORCEMENT (HVE) GRANT FOR FY 2025**

WHEREAS, the Village of Forest Park (“Village”) has made application to the Illinois Department of Transportation (“IDOT”) for a grant to be funded through the Sustained Traffic Enforcement Program (“STEP”) for High Visibility Enforcement (HVE) for targeted enforcement designed to reduce fatalities and serious injuries at some of the deadliest times of the year for vehicle travel (“Grant”); and

WHEREAS, the Village has been awarded and is required to accept the terms of the STEP and HVE Grant with IDOT, in the amount of \$46,464.00.

NOW, THEREFORE, BE IT RESOLVED by the Mayor and Council of the Village of Forest Park, Cook County, Illinois, as follows:

Section 1. The application for the STEP and HVE Grant, in the amount of \$46,464.00, be approved and the Chief of Police is authorized to execute, on behalf of the Village, the STEP and HVE Grant with IDOT, a copy of which is attached hereto as Exhibit “A”.

Section 2. The Chief of Police or his designee is hereby authorized and directed to execute any and all other documents and to perform all other requirements in connection with the request for the STEP and HVE Grant.

Section 3. The Village agrees to accept the \$46,464.00 STEP and HVE Grant from IDOT, and further agrees to use the funds received pursuant to said STEP and HVE Grant.

ADOPTED by the Council of the Village of Forest Park, Cook County, Illinois this 12th
day of August, 2024.

AYES: _____

NAYS: _____

ABSENT: _____

APPROVED by me this 12th day of August, 2024.

Rory E. Hoskins, Mayor

ATTESTED and filed in my office,
And published in pamphlet form
This _____ day of August, 2024.

Vanessa Belmonte, Village Clerk

EXHIBIT "A"

FY 2025 IDOT STEP AND HVE GRANT

**Village of Forest Park
Council Agenda Item Summary**

Council Meeting Date:	August 12, 2024	Presented By:	Chief Ken Gross
Agenda Item Title:	Illinois Dept. of Transportation	Budgeted Item:	Yes: Not Applicable No:
Budget Account Number:	Grant	Amount Budgeted:	\$46,464.00
Council Executive Summary			
<p>The Forest Park Police Department has been awarded a Highway Safety Program Grant for FFY25. The grant will allow us to conduct special enforcements for impaired driving mobilizations and/or occupant protection mobilizations during the following holidays and/or events: Thanksgiving, Christmas, New Years, Super Bowl, St. Patrick's Day, Memorial Day, Independence Day, Labor Day and Distracted Driving.</p> <p>Total grant funding is \$46,464.00</p>			
Recommended Action			
It is the recommendation of the Police Department that the Mayor and Village Council approve the IDOT FFY2025 funding.			
Approved:	Denied:	Deferred:	
Other Comments:			



Village of Forest Park

Prepared by Village of Forest Park
for Illinois Department of Transportation State and Community Highway Safety/National Priority Safety Program; 25-0343-
11 Sustained Traffic Enforcement Program (STEP)

Submitted by Dora Murphy

Submitted on 01/15/2024 8:00 AM Central Standard Time



Opportunity Details

Opportunity Information

CSFA Number
494-10-0343

CSFA Popular Name
NHTSA Section 402, Section 405, and 1906 funds and State of Illinois funds

Title
State and Community Highway Safety/National Priority Safety Program; 25-0343-11 Sustained Traffic Enforcement Program (STEP)

Description

I. INTRODUCTION:

The Sustained Traffic Enforcement Program (STEP) focuses on High Visibility Enforcement (HVE) at specific times on specific dates throughout the year. The enforcement efforts are designed to reduce fatalities and serious injuries at some of the deadliest times of the year for vehicle travel. There are six required campaigns for this program. Applicants also have the opportunity to participate in optional campaigns and/or additional traffic safety enforcement.

II. PROJECT GOAL:

Increase high visibility enforcement of traffic safety laws in Illinois.

III. REMINDERS FOR THIS YEAR:

- Mandatory Campaign Funds become more flexible – funding for these campaigns will operate similarly to the additional enforcement. See mandatory campaigns section for elaboration.
- SPEED Optional Campaign – July 8- August 1, 2025
- Additional Traffic Safety Enforcement funds can be requested up to one hundred (100) percent of total mandatory and optional enforcement amount.
- The claim for reimbursement is due within 45 days after the end of the enforcement campaign or the end of month when Additional Enforcement is worked.
- Create meaningful public participation and engagement to ensure diverse views are heard and considered.
- It is recommended that grantee completes the budget calculation sheet first in order to calculate the total amount being requested.

IV. GRANT PROPOSAL GUIDANCE:

This section will cover the requirements of Mandatory, Optional campaigns, and Additional Enforcement.

Campaign Specifications:

A. Mandatory Enforcement Campaigns – these campaigns are a requirement of the grant and agencies must participate. The applicant agency can apply for funds to conduct Impaired Driving and/or Occupant Protection enforcement for each campaign.

In the application, the applicant will designate how much funding they need for each campaign, but this will only be used to justify their participation and overall dollar amount.

During the grant year, the agency will spend funds on the campaigns as needed. These funds will operate as a lump sum that can be used throughout the year. Agencies are not required to seek approval to move funds from one campaign to another.



AGENCIES ARE REQUIRED TO PARTICIPATE IN ALL 6 CAMPAIGNS AND MUST BUDGET ACCORDINGLY THROUGHOUT THE YEAR TO ENSURE COMPLIANCE WITH THIS REQUIREMENT.

Agencies must participate in the following campaigns with the predetermined message and enforcement emphasis:

- Thanksgiving (Shared Occupant Protection/Impaired Driving Message)
- Christmas/New Year's (Impaired Driving)
- St. Patrick's Day (Impaired Driving)
- Memorial Day (Occupant Protection)
- Independence Day (Impaired Driving)
- Labor Day (Impaired Driving)

Mandatory Enforcement Campaign Requirements:

The applicant can apply for funds to conduct Impaired Driving and/or Occupant Protection enforcement for each campaign but at least one must be conducted. There are separate requirements and desired outputs for each enforcement type. Each campaign will also have a primary message and enforcement emphasis (e.g. "Click It or Ticket" or "Drive Sober Or Get Pulled Over"). Agencies are encouraged to conduct enforcement campaigns for both Impaired Driving and Occupant Protection. Other traffic safety citations should be issued where appropriate, during mandatory campaigns. Examples of other citations for violations directly relating to contributory causes of crashes would be speeding, electronic device use, failure to yield, disobeying traffic control signal/device, etc., in addition to impaired driving arrests and occupant restraint (seat belt/child restraint) citations.

Explanation of Operation:

EXAMPLE - Your agency was awarded \$1,000 for each of the six campaigns below for a total of \$6,000 in mandatory campaigns. How you spend those funds is up to your agency. As seen below you asked for \$1,000 for each campaign but it was spent as it was needed and no approvals to move the funds is required.

- Thanksgiving Occupant Protection \$2,500
- Christmas/New Year's (Impaired Driving) \$500
- St. Patrick's Day (Impaired Driving) \$250
- Memorial Day (Occupant Protection) \$250
- Independence Day (Impaired Driving) \$1,500
- Labor Day Occupant Protection \$1,000

MUST STILL DEFINE THE ENFORCEMENT TYPE ON THE CITATION REPORTING FORM (BSPE 205 or equivalent).

Occupant Protection Enforcement:

- A minimum of thirty (30) percent of total mandatory campaign hours for the grant year shall be worked between the hours of 6:00 p.m. and 6:00 a.m.
- Nighttime hours can be scheduled when most appropriate by the grant agency. (Example; If an agency's total mandatory and optional campaign hours add up to 100 hours, a minimum of 30 hours must be worked between 6:00 p.m. and 6:00 a.m.). Thus, the agency has the flexibility to schedule nighttime hours when most appropriate during the grant year.
- Thirty (30) percent of all citations while working Occupant Protection enforcement should be for occupant restraint violations.
- See the Desired Outputs section for citation/traffic stop expectations.

Impaired Driving Enforcement:

- Patrol hours must occur between 6:00 p.m. and 6:00 a.m.

Impaired driving patrol hours may be extended outside of 6:00 p.m. and 6:00 a.m. with pre-approval from an IDOT Safety Grant Administrator (GA).

Daytime patrol hours can be conducted BY ARIDE/DRE-TRAINED OFFICERS ONLY between the hours of 6:00 a.m. and 6:00 p.m.

- All officers conducting grant-funded, alcohol-related enforcement must be trained in the Standardized Field Sobriety

Test (SFST). Approved training in this area consists of the 24-hour National Highway Traffic Safety Administration (NHTSA), DWI Detection and SFST Course or other NHTSA/ILETSB-approved refresher course. To satisfy this requirement, officers must complete an ILETSB-accredited academy, a 24-hour SFST course or an SFST refresher course every four (4) years from the date of their last completed certified training. These courses must be taught by certified SFST instructors. Note: A law enforcement agency may provide in-house training for its own officers conducted by officers from the same agency, provided the trainer is a certified ILETSB SFST instructor. Officers may also attend training at an agency other than their own if the training is conducted by a certified SFST instructor. In these situations, a class roster showing all officers who completed the training must be sent to the ILETSB. Upon request, law enforcement agencies must be able to produce verification of compliance with this requirement.

- See the Desired Outputs section for citation/traffic stop expectations.

B. Optional Enforcement Campaigns – An agency may participate in any number of optional campaigns but there is no requirement to do so.

Agencies may participate in the following campaigns with the predetermined message emphasis:

- Halloween (Impaired Driving)
- Super Bowl (Impaired Driving)
- Distracted Driving (Distracted Driving)
- Speed Awareness (Speeding)
- Child Passenger Safety (Occupant Protection)

Optional Enforcement Campaign Requirements:

Like the mandatory campaigns, the applicant agency can apply for funds to conduct Impaired Driving and/or Occupant Protection enforcement for the Halloween and Super Bowl campaigns. Distracted Driving, Speed and Child Passenger Safety only have one campaign focus, but all campaigns will have a primary message and enforcement emphasis (as seen above). Although the focus of the campaign may be occupant protection, impaired driving, child passenger safety, speed, or distracted driving, officers/deputies are encouraged to issue other citations for violations directly relating to contributory causes of crashes. For example, speeding, electronic device use, failure to yield, disobeying traffic control signal/device, etc., in addition to impaired driving arrests and occupant restraint (seat belt/child restraint) citations.

Occupant Protection Enforcement

- See Mandatory Occupant Protection Enforcement Requirements

Impaired Driving Enforcement:

- See Mandatory Impaired Driving Enforcement Requirements

Distracted Driving Enforcement:

- Only conducted in the month of April.
- No time of day or day of week requirements.
- See the Desired Outputs section for citation/traffic stop expectations.

Speed Enforcement:

- Only conducted during the specified dates of July 8 - August 1st.
- See the Desired Outputs section for citation/traffic stop expectations.

C. Additional Enforcement - Agencies can apply for funding to conduct additional enforcement along with the mandatory and optional campaigns. The focus, time, and date are completely up to the department based on their traffic enforcement needs but they cannot be used during the mandatory campaign dates. Agencies shall conduct enforcement focusing on contributory causes of crashes, i.e., speeding, impaired driving, electronic device use, failure to yield, disobeying traffic control signal/device, as well as occupant restraint violations.

Agencies can apply for funds as one lump sum under this section without defining a specific enforcement type. These additional enforcement funds will be used when the agency decides it is most necessary, as long as it is outside of the



mandatory campaign dates. Funds can be used as needed throughout the grant year.

Additional Enforcement Requirements:

- Additional Traffic Safety Enforcement efforts can be scheduled anytime, day or night outside the mandatory campaign dates.

Agencies shall conduct enforcement focusing on contributory causes of crashes, i.e., speeding, impaired driving, electronic device use, failure to yield, disobeying traffic control signal/device, as well as occupant restraint violations.

- Additional Traffic Safety Enforcement funds cannot exceed one hundred (100) percent of the requested mandatory and optional enforcement funds.

- Agencies shall submit only one citation/arrest data reporting form and one reimbursement claim for all additional enforcement for the entire month when that enforcement was worked. The BSPE citation reporting form shall be submitted within two weeks from the end of the month when work was completed. The reimbursement claim (BSPE 500) shall be submitted within 45 days from the end of the month when work was completed. This is in addition to the reporting forms for any optional campaign enforcement done in that time frame.

- See the Desired Outputs section for citation/traffic stop expectations.

- Note: Agencies are allowed to conduct additional enforcement within optional campaigns timeframes if the agency is not conducting enforcement during that optional campaign. The only exception is when the optional enforcement is scheduled for the entire month during the Distracted Driving and Speed campaigns.

Desired Outputs by Enforcement Campaign Type:

Mandatory and Optional Campaigns:

Occupant Protection (includes Child Passenger Safety):

1. Average a minimum of one (1) traffic enforcement contact for every 60 minutes of patrol.
2. Thirty (30) percent should be for occupant restraint violations.
 - a. Front and back seat, child or adult occupants.

Impaired Driving:

1. A minimum of one impaired driving arrest for every fifteen (15) hours of patrol.
2. Average a minimum of one (1) traffic enforcement contact for every sixty (60) minutes of patrol.

Distracted Driving (optional campaign only):

1. Average a minimum of one (1) traffic enforcement contact for every 60 minutes of patrol.
2. Fifty (50) percent should be for electronic device use violations.

Speed (optional campaign only):

1. Average a minimum of one (1) traffic enforcement contact for every 60 minutes of patrol.
2. Fifty (50) percent should be for speed violations.

Additional Enforcement:

1. Average a minimum of one (1) traffic enforcement contact for every 60 minutes of patrol.
2. Average a minimum of two (2) traffic stops per hour.

Campaign Requirements:

For each mandatory, optional, and additional campaign completed, the agency shall:

- Conduct pre- and post-enforcement activities. Examples: social media; news releases; TV interviews; media events; community education; and court (prosecutors and judges) personnel; etc.
- Patrols must be continual and spread out over the enforcement campaign period during times of high crash incidence.



- Obtain and collect data from campaign. Report this information on the BSPE 205 or equivalent form determined by the grantor.
- Officers are encouraged to issue multiple citations to drivers and/or passengers who have committed multiple violations.
- The applicant agency may be asked to participate in promotional events and regional meetings at the request of BSPE.
- Create meaningful public participation and engagement to ensure diverse views are heard and considered.

ALLOWABLE COSTS

Allowable Budget Line Requests

Personnel Salary and Wages.

Indirect Costs Calculated by applying the current negotiated indirect cost rate (ICR) percentage to the approved or projected base.

VI. POLICIES AND GUIDANCE FOR FFY 2025:

COMPENSATION TIME REIMBURSEMENT:

Officers may earn comp-time if the agency is compensated at the current agreed rate and it will be the same rate, no matter if it is pay or comp-time. Like any other grant reimbursement, the time worked must be billed within the grant period, at the rate established and at the time the officer worked the grant. If officer/deputy is receiving compensation time, please denote with (COMP) after their name. Your agency will still be billing our office for the hours worked and we will still be reimbursing them. The only change is that your department will give your officers comp time instead of pay.

Awarding Agency Name

Department Of Transportation

Agency Contact Name

Aaron Link

Agency Contact Phone

2177853084

Agency Contact Email

Aaron.Link@illinois.gov

Fund Activity Categories

Transportation

Category Explanation

A state may use these grant funds only for highway safety purposes. Encourage States to address national priorities for reducing highway deaths and injuries through occupant protection programs, state traffic safety information system improvements, impaired driving countermeasures, passage of effective laws to reduce distracted driving, implementation of motorcyclist safety programs, racial profiling data, and the implementation of graduated driving licensing laws.

Departments

Highway Safety Grants - Bureau of Safety Programs and Engineering -

Subjects

Federal Fiscal Year 2025

Opportunity Manager

Aaron Link

Opportunity Posted Date

1/1/2024



Announcement Type

Initial Announcement

Funding Opportunity Number

25-0343-11

Assistance Listings Number

20.600, 20.616, 20.611

Public Link

<https://il.amplifund.com/Public/Opportunities/Details/52467a59-8c3c-4e3f-9d91-a51c1f866518>

Is Published

Yes

Funding Information

Total Program Funding

\$13,000,000.00

Funding Sources

Federal Or Federal Pass Through, State

Funding Source Description

State Funds and FAST Act/Infrastructure Investment and Jobs Act federal funding Sections 402 and all 405 sections depending on the specific grant objectives.

Bipartisan Infrastructure Law (BIL P.L. 177-58)

Allowable Budget Items: Personnel and Indirect Costs.

Funding Restrictions

See funding source description

Award Information

Award Period

10/01/2024 - 09/30/2025

Award Type

Competitive

Capital Grant

No

Expected Number of Awards

250.00

Indirect Costs Allowed

Yes

Indirect Cost Description

All applicants must provide documentation that there is an acceptable accounting system in place that is capable of identifying project related costs separate from general operating costs.

(2CFR Part 200, Appendix VII.D.b); (2 CFR 200.47)

Please see "question submission information" section for the IDOT University Indirect Cost Policy Memo as referenced in the "citation governing indirect cost restriction section".



Restrictions on Indirect Costs

Yes

Citation Governing Indirect Cost Restriction

Allowed. "The following State University F and A Rate and Base will apply to all State issued awards that contain either Federal pass-through funding or State funding: RATE: 20% Rate for awards or programs administered On-Campus* 10% Rate for awards or programs administered Off-Campus* BASE: Base approved in the State Universities' current Federally Negotiated Indirect Cost Rate Agreement (NICRA) *Criteria for utilization of the On/Off Campus rate is located within the general terms and conditions of Federal NICRA for each State University. If not clearly defined, State awarding agencies and officers will make final determination based upon the purposes of the grant scope." (See attached University Indirect Cost Rates Memorandum, January 2020). 2CFR 200

Submission Information

Submission Window

01/02/2024 12:00 AM - 02/16/2024 4:00 PM

Submission Timeline Type

One Time

Submission Timeline Additional Information

A Highway Safety Grant application is not considered complete until all required documents are received.

No submissions will be accepted after the deadline.

Allow Multiple Applications

Yes

Application Review Start Date / Pre-Qualification Deadline

03/01/2024 12:00 AM

Question Submission Information

Question Submission Open Date

01/01/2024 12:00 AM

Question Submission Close Date

02/16/2024 4:00 PM

Question Submission Email Address

DOT.TSgrants@illinois.gov

Question Submission Additional Information

GATA Compliance:
Aaron Link
DOT.TSgrants@illinois.gov

Attachments

- IDOT University Indirect Cost Rate Policy Memo

Eligibility Information

Eligibility Type

Public

Eligible Applicants

- County Governments



- City or township governments
- Special District Governments
- Public and State controlled institutions of higher education
- Native American tribal governments (Federally recognized)
- Native American tribal organizations (not Federally recognized)
- Private institutions of higher education
- Others
- Government Organizations

Additional Eligibility Information

This grant program is only available to non-state agency law enforcement agencies.

Additional Information

Additional Information URL

<https://idot.illinois.gov/transportation-system/transportation-safety/safety-grants/apply.html>

Additional Information URL Description

Information posted in this Notice of Funding Opportunity is also posted on our website for ease of use.

Award Administration Information

State Award Notices

Awards will be issued prior to the grant start date.

Administrative and National Policy Requirements

This NOFO is restricted by policies set forth in the FAST Act (Infrastructure Investment and Jobs Act and 2 CFR 200.) and the Bipartisan Infrastructure Law (BIL P.L. 117-58)

Reporting

The Periodic Financial Report is required at a minimum of four (4) times per year but may be required more frequently. Each Grantee's final reporting frequency shall be in the grant agreement.

Citation reporting information is due within 15 days of the end of the enforcement campaign. At this time, it is unclear if this information will be submitted to the grantor VIA AmpliFund or the past practice VIA email. The grantor will make this determination at a later time.

In addition, the Grantee's assigned Safety Grant Administrator may have monitoring meetings throughout the grant year.

State Awarding Agency Contacts

Aaron Link
Illinois Department of Transportation
Bureau of Safety Programs and Engineering
2300 South Dirksen Parkway
Springfield, Illinois 62764
217-785-3084
Aaron.Link@Illinois.gov



Project Information

Application Information

Application Name

Village of Forest Park

Award Requested

\$46,464.00

Cash Match Requirement

\$0.00

Cash Match Contributions

\$0.00

In-Kind Match Requirement

\$0.00

In-Kind Match Contributions

\$0.00

Other Funding Requirement

\$0.00

Other Funding Contributions

\$0.00

Total Award Budget

\$46,464.00

Primary Contact Information

Name

Dora Murphy

Email Address

dmurphy@forestpark.net

Address

517 Desplaines Avenue
Forest Park, Illinois 60130

Phone Number

708-615-6223



Project Description

2025 BSPE Local Enforcement Agency Calculation Guidance

Read and follow these instructions

This form is used to provide information and guidance to help develop your proposal parts 2, 3, and 4 and the budget.

Failure to follow these instructions will negatively impact your application and potential award.

Applicants should submit budgets based upon the total estimated costs for the project including all funding sources. Pay attention to applicable program-specific instructions in the NOFO.

VERIFY CALCULATIONS

Within the proposal documents the applicant will need to input the amount of hours and calculate total dollar amounts in a variety of places. It is imperative that the amounts are checked and verified. If amounts are incorrect, the application will be sent back to correct and may impact the funding of the application.

If an effort to help with these calculations we have created a excel sheet that will do most of the calculations for the applicant and it can be used to verify the correct numbers were placed in the proposal and budget document within AmpliFund.

You must download the form and use it. It will be required to be uploaded in a later form.

Click on the green highlighted text below to download the file for use.

Excel Check Sheet

Enforcement Strategy Worksheet

[Enforcement Strategy Worksheet.xlsx](#)

Verify Calculations with Excel Check Sheet

Acknowledgement

I have reviewed the information provided on this page

Next Steps

When you're finished answering the questions on this page, click [Mark as Complete](#). An application cannot be submitted until all pages are marked as complete. Not finished with this page yet? Click [Save](#) or [Save & Continue](#) to fill out the missing information at a later time.



2025 BSPE Local Enforcement Agency Budget Guidance

How to Complete the Actual Budget Form

Budget Form Guidance (Click on the plus sign to input personnel and indirect costs.)

The next document the applicant will be filling out is the Budget Form. This is the official budget form that will be included with the grant agreement if awarded.

Sustained Traffic Enforcement Program only allows for Personnel and Indirect Costs.

Below explains what information will be inputted into the budget form. We have explained each area and given example answers for all required areas.

Personnel

Name - Hireback Officers

Position - Hireback Officers

Salary Amount - Overtime rate of pay used in the excel spreadsheet

Basis - Hourly

% of time - 1 = 100%

Length of time - Number of total hours - see the excel spreadsheet

Narrative - Put in average hourly overtime rate and number of total hours.

Indirect Costs

Name - Hireback Officers

Base - Dollar amount of Hireback Officer costs - see excel sheet or what was put in personnel.

Rate* - Percent rate your agency is approved for - please note that it must be put in decimal format - 1 = 100%

Failure to follow these instructions will negatively impact your application and potential award.

VERIFY CALCULATIONS

Make sure all of the information from the proposal documents, the excel sheet, and the budget match.

It is imperative that the amounts are checked and verified. If amounts are incorrect, the application will be sent back to correct and may impact the funding of the application.

As an additional check the applicant will need to upload the completed excel sheet previously downloaded



and filled out. This will only be used to help the grantor verify calculations.

In the area below you will click on the gray box and upload your file.

Also note that the "Award Requested" amount on the Project Information Form must match the budget total. If they do not, you will not be able to submit. You can go back at any time and update the "Award Requested" amount.

Excel Check Sheet Upload

Upload your completed Excel Check Sheet.

Enforcement Strategy Worksheet.xlsx

Understanding of Required Information

Acknowledgement

I have reviewed the information provided on this page

Next Steps

When you're finished answering the questions on this page, click [Mark as Complete](#). An application cannot be submitted until all pages are marked as complete. Not finished with this page yet? Click [Save](#) or [Save & Continue](#) to fill out the missing information at a later time.



2025 Local Agency Uniform Grant Application

Fill in the following information and be sure to check with your finance office to ensure you are supplying the correct information.

Applicant Information

Legal Name (Name used for UEI registration and grantee pre-qualification)

Forest Park, Village of

Common Name (DBA)

Forest Park Police Department

Employer/Taxpayer Identification Number (EIN, TIN)

36-6005875

SAM Cage Code

4KZD4

Unique Entity Identifier

JGWJBEJKDTF6

Payment Address

Does your agency have a different payment address than the principal office registered in the GATA portal?

YES

NO

Applicant's Organizational Unit

Department Name

Forest Park Police

Division Name

Applicant's Name and Contact Information for Person to be Contacted for Program Matters involving this Application

First Name

Christopher

Last Name

Chin

Suffix

Title

Deputy Chief of Police

Organizational Affiliation

Employee

Telephone Number

708-615-6221

Email Address



cchin@forestpark.net

Applicant's Authorizing Representative information - this person will be signing the grant agreement if awarded.

First Name

Rachell

Last Name

Entler

Title

Village Administrator

Telephone Number

708-615-6202

Email Address

rentler@forestpark.net

Areas Affected

Please list the areas affected by the Project (cities, counties, state-wide)

Forest Park & Cook County

Add Attachments (e.g., maps) (optional)

Legislative and Congressional Districts of Applicant

Legislative and Congressional Districts of Program/Project

Attach an additional list, if necessary

Applicant's Project

Description Title of Applicant's Project

STEP

Proposed Project Term Start Date

10/1/2024

Proposed Project Term End Date

9/30/2025

Applicant Certification

By signing this application, I certify (1) to the statements contained in the list of certifications* and (2) that the statements herein are true, complete and accurate to the best of my knowledge. I also provide the required assurances* and agree to comply with any resulting terms if I accept an award. I am aware that any false, fictitious, or fraudulent statements or claims may subject me to criminal, civil or administrative penalties. (U.S. Code, Title 18, Section 1001)

(*)The list of certification and assurances, or an internet site where you may obtain this list is contained in the Notice of Funding Opportunity. If a NOFO was not required for the award, the state agency will specify required assurances and certifications as an addendum to the application.

Applicant Certification



I agree

Next Steps

When you're finished answering the questions on this page, click [Mark as Complete](#). An application cannot be submitted until all pages are marked as complete.

Not finished with this page yet? Click [Save](#) or [Save & Continue](#) to fill out the missing information at a later time.



Affidavit of Disclosure of Conflicts of Interest

This Affidavit of Disclosure of Conflicts of Interest is to be completed by the highest-ranking position overseeing the grant. If more than one Affidavit of Disclosure of Conflicts of Interest needs to be submitted per Grantee requirements, email DOT.TSgrants@Illinois.gov for submission directions.

Name of Employee Completing the Affidavit of Disclosure of Conflicts of Interest
Letitia Olmsted

Position of Employee Completing the Affidavit of Disclosure of Conflicts of Interest
Finance Director

Grantee's disclosure of the information contained in this Form is required by the Uniform Administrative Requirements, Cost Principles, and Audit Requirements for Federal Awards published in Title 2, Part 200 of the Code of Federal Regulations, 2 CFR 200.112, and 44 Ill. Admin Code 7000.40(b)(3). As an Employee or Officer of Grantee, I will remain bias-free before, during and after the award process of the Grant Agreement. Pursuant to the above referenced Uniform Guidance and Administrative Rules, I have identified below any relationship I have, or have had, of a family, political, financial, or social nature with any of Grantor's employees related to this Grant Agreement, and wait for direction from the Grants Unit Manager and the Department's Ethics Officer before proceeding to participate with Grantor in the award process. After submittal of this Disclosure to the Department's Bureau of Business Services, the Bureau of Business Services will provide this form to the Ethics Officer if a conflict is noted.

I have, or have had, a relationship described above or other conflict of interest with the following employees of Grantor for this Grant Agreement.

- YES
- NO

Submittal Verification

By checking this box and typing my name below, I verify this document has been reviewed and approved by the owner and myself.

Approver Name
Letitia Olmsted

Date
1/9/2024

Next Steps

When you're finished answering the questions on this page, click [Mark as Complete](#). An application cannot be submitted until all pages are marked as complete.
Not finished with this page yet? Click [Save](#) or [Save & Continue](#) to fill out the missing information at a later time.



2025 BSPE Local Agency Enforcement Proposal (Part 1)

Application Guidance

This form will be used for the Bureau of Safety Programs and Engineering to aid in the evaluation of this application. It will also be used to evaluate the progress of your grant, if you are selected. Please be aware you will be responsible for completing all objectives and program implementation activities. Be specific with data, locations, dates, and activities. SAVE YOUR PROGRESS REGULARLY TO ENSURE INFORMATION IS NOT LOST.

1) Problem Identification

a) Based on your agency's coverage area and crash data, what are your agency's highway safety issues and explain your need for hireback enforcement.

Harlem/Roosevelt; Harlem/Madison; Roosevelt/Desplaines; Roosevelt/Circle; Madison/Circle

2) Illinois Strategic Highway Safety Plan

Did your agency use the Strategic Highway Safety Plan to develop this application?

- YES
 NO

2022 Strategic Highway Safety Plan

Strategic Highway Safety Plan 2022.pdf

3) Enforcement Focus

What are the enforcement focuses of this grant application? (Check all that apply)

- Distracted Driving
 Impaired Driving
 Seat Belt Compliance
 Child Passenger Safety
 Speed
 Move Over Law
 Pedestrian
 Pedalcycle
 Other

Other

4) Illinois Traffic Stop Study

Does your agency comply with the Illinois Traffic Stop Study?

- YES
 NO

5) Location of Planned Enforcement

In what county is your agency located?

Cook

County Population Map

County Population Model.pdf

6) Population

What is the population of your agency's jurisdiction?

15700



7) Personnel

Estimated Number of Officers to participate in this enforcement program.

38

Estimated overtime rate of pay to participate in this enforcement program.

89.00

Does your agency have the necessary staff to conduct and support IDOT's enforcement campaigns?

YES

NO

8) Personnel Training

How many officers are ARIDE Trained?

12

How many officers are DRE Trained?

4

How many officers are Phlebotomy Trained?

0

How many officers are Breath Alcohol Technicians?

8

How many officers are Child Passenger Safety Technicians?

0

9) Additional Activities

What activities will your agency be conducting outside of enforcement to further highway safety? (examples: press releases, social media following, outreach events, etc.) If you have more than five, please list the most impactful.

	Description of Activity	Quantity of Activity	Quantity of People Reached
Activity 1	Social Media	8	15,700
Activity 2	Village web-site	8	15,700
Activity 3			
Activity 4			
Activity 5			

10) Equitable enforcement practices

How does your agency provide outreach and engagement opportunities to the underserved and diverse populations in your community?

We hold department wide training twice a year in addition to monthly training through Lexipol, Covered trainings are: Deescalation

strategies for street safe encounters; cultural competency; ethical and cultural awareness; use of force; sexual

harassment and we also utilize the on-line training thru ILETSB.

Next Steps



When you're finished answering the questions on this page, click [Mark as Complete](#). An application cannot be submitted until all pages are marked as complete.

Not finished with this page yet? Click [Save](#) or [Save & Continue](#) to fill out the missing information at a later time.



2025 Local Agency Enforcement Programmatic Risk Assessment (PRA)

No Longer Required by Applicant

The content from the Programmatic Risk Assessment (PRA) has been added into the Internal Control Questionnaire (ICQ) that should have already been completed by your agency. Therefore, the previously completed PRA is no longer necessary. The ICQ and an Illinois Department of Transportation internal risk assessment will identify risk for your agency. If awarded and if risk is identified, it will be found in the specific conditions in the grant agreement.

Next Steps

When you're finished answering the questions on this page, click [Mark as Complete](#). An application cannot be submitted until all pages are marked as complete.

Not finished with this page yet? Click [Save](#) or [Save & Continue](#) to fill out the missing information at a later time.



Budget

Proposed Budget Summary

Expense Budget

	Grant Funded	Non-Grant Funded	Total Budgeted
1. Personnel (Salaries and Wages) (2 CFR 200.430)			
Hireback Officers	\$46,464.00	\$0.00	\$46,464.00
Subtotal	\$46,464.00	\$0.00	\$46,464.00
Total Proposed Cost	\$46,464.00	\$0.00	\$46,464.00

Revenue Budget

	Grant Funded	Non-Grant Funded	Total Budgeted
Grant Funding			
Award Requested	\$46,464.00		\$46,464.00
Subtotal	\$46,464.00		\$46,464.00
Non-Grant Funding			
Cash Match		\$0.00	\$0.00
In-Kind Match		\$0.00	\$0.00
Other Funding and Contributions		\$0.00	\$0.00
Subtotal		\$0.00	\$0.00
Total Proposed Revenue	\$46,464.00	\$0.00	\$46,464.00

Proposed Budget Detail

See attached spreadsheet.

Proposed Budget Narrative

1. Personnel (Salaries and Wages) (2 CFR 200.430)

List each position by title and name of employee, if available. Show the annual salary rate and the percentage of time to be devoted to the project and length of time working on the project. Compensation paid for employees engaged in grant activities must be consistent with that paid for similar work within the applicant organization. Personnel cannot exceed 100% of their time on all active projects.

Hireback Officers

Overtime Rate of \$88.00 X 528 hours

RESOLUTION NO. R-_____ -24

**A RESOLUTION AUTHORIZING AND ACCEPTING A GRANT AGREEMENT
BY AND BETWEEN THE ILLINOIS DEPARTMENT OF REVENUE
AND THE VILLAGE OF FOREST PARK FOR THE
FY 2025 TOBACCO ENFORCEMENT PROGRAM GRANT**

WHEREAS, the Village of Forest Park has made application to the Illinois Department of Human Services (“IDHS”) for a Tobacco Enforcement Program Grant (“Grant”); and

WHEREAS, the Village has been granted and is required to accept the terms of the Grant with IDHS in the amount of \$3,407.00.

NOW, THEREFORE, BE IT RESOLVED by the Mayor and Council of the Village of Forest Park, Cook County, Illinois, that the request for the Grant, in the amount of \$3,407.00, be accepted and approved.

BE IT FURTHER RESOLVED that the Chief of Police is authorized to execute, on behalf of the Village of Forest Park, the acceptance of the Grant with IDHS, a copy of which is attached hereto as Exhibit “A” and made a part hereof.

BE IT FURTHER RESOLVED that the Chief of Police or his designee is hereby authorized and directed to execute any and all other documents and to perform all other requirements in connection with the request for the Grant.

BE IT FURTHER RESOLVED that the Village of Forest Park agrees to accept the \$3,407.00 Grant from IDHS, and further agrees to use the funds received pursuant to said Grant.

[REMAINDER OF PAGE INTENTIONALLY LEFT BLANK]

ADOPTED by the Council of the Village of Forest Park, Cook County, Illinois this 12th
day of August, 2024.

AYES: _____

NAYS: _____

ABSENT: _____

APPROVED by me this 12th day of August, 2024.

Rory E. Hoskins, Mayor

ATTESTED and filed in my office,
And published in pamphlet form
This _____ day of August, 2024.

Vanessa Belmonte, Village Clerk

EXHIBIT A

FY 2025 Tobacco Enforcement Program Grant

**Village of Forest Park
Council Agenda Item Summary**

Council Meeting Date:	August 12, 2024	Presented By:	Chief Ken Gross
Agenda Item Title:	Tobacco Grant FY25	Budgeted Item:	Yes: Not Applicable No:
Budget Account Number:	Grant	Amount Budgeted:	\$3,407.00
Council Executive Summary			
<p>The Forest Park Police Department has been awarded a Tobacco Grant Program from the Illinois Department of Human Services to conduct stings on each tobacco retailer in Forest Park. The Forest Park Police Department will conduct (1) one retailer kit distribution detail and a total of three (3) compliance checks details between November 30, 2024 and May 31, 2025.</p> <p>Total grant funding is \$3,407.00</p>			
Recommended Action			
It is the recommendation of the Police Department that the Mayor and Village Council approve the Illinois Department of Human Services / Tobacco Grant funding.			
Approved:	Denied:	Deferred:	
Other Comments:			



**State of Illinois
UNIFORM GRANT BUDGET TEMPLATE**

Agreement Number: N/A

State Agency Illinois Department of Human Services

FY. 2025

Grantee Village of Forest Park

Notice of Funding Opportunity (NOFO) Number: N/A

Data Universal Number System (DUNS) Number 076891365

FEIN 366005875

Catalog of State Financial Assistance (CSFA) Number 444-26-1565

CSFA Short Description. TOBACCO ENFORCEMENT PROGRAM

Catalog of Federal Domestic Assistance (CFDA) Number N/A

CFDA Short Description. N/A

Section A: State of Illinois Funds

REVENUES	Total
State of Illinois Requested:	\$3,407.00
Budget Expenditure Categories	
1. Personnel (200.430)	N/A
2. Fringe Benefits (200.431)	N/A
3. Travel (200.475)	N/A
4. Equipment (200.439 and 200.436(a))	N/A
5. Supplies (200.1 and 200.453)	N/A
6. Contractual Services/Subawards (200.318 and 200.1)	N/A
7. Consultant (200.459)	N/A
8. Construction	N/A
9. Occupancy - Rent and Utilities (200.465 and 200.436(a))	N/A
10. Research and Development (R & D) (200.1)	N/A
11. Telecommunications	N/A
12. Training and Education (200.473)	N/A
13. Direct Administrative Costs (200.413)	N/A
14. Other or Miscellaneous Costs	N/A
15. Grant Exclusive Line Item(s)	\$3,407.00
16. Total Direct Costs (add lines 1-15) (200.413)	\$3,407.00
17. Indirect Cost (200.414)	N/A
Rate %: N/A	
Base: N/A	
18. Total Costs State Grant Funds Lines 16 and 17 MUST EQUAL REVENUE TOTALS ABOVE	\$3,407.00



**State of Illinois
UNIFORM GRANT BUDGET TEMPLATE**

Agreement Numbers. N/A

State Agency Illinois Department of Human Services

FY. 2025

Grantee Village of Forest Park

Notice of Funding Opportunity (NOFO) Number. N/A

Data Universal Number System (DUNS) Number 076891365

FEIN 366005875

Catalog of State Financial Assistance (CSFA) Number 444-26-1565

CSFA Short Description. TOBACCO ENFORCEMENT PROGRAM

Catalog of Federal Domestic Assistance (CFDA) Number N/A

CFDA Short Description. N/A

SECTION A - (Continued) - Indirect Cost Rate Information

If your organization is requesting reimbursement for indirect costs on line 17 of the Budget Summary, please select one of the following options.

1. Our Organization receives direct Federal funding and currently has a Negotiated Indirect Cost Rate Agreement (NICRA) with our Federal Cognizant Agency. A copy of this agreement will be provided to the State of Illinois' Indirect Cost Unit for review and documentation before reimbursement is allowed. This NICRA will be accepted by all State of Illinois Agencies up to any statutory, rule-based or programmatic restrictions or limitations.

NOTE: (If this option is selected, please provide basic Negotiated Indirect Cost Rate Agreement information in area designated below)

Your organization may not have a Federally Negotiated Cost Rate Agreement. Therefore, in order for your organization to be reimbursed for the Indirect Costs from the State of Illinois your organization must either:

- A. Negotiate an Indirect Cost Rate with the State of Illinois' Indirect Cost Unit with guidance from your State Cognizant Agency on an annual basis;**
 - B. (Local Government Unit only) Submit a copy of your Federal Rate Maintained Internally (State FRMI) with the State of Illinois' Indirect Cost Unit with guidance from your State Cognizant Agency on an annual basis;**
 - C. Elect to use the de minimis rate of 10% modified for total direct costs (MTDC) which may be used indefinitely on State of Illinois awards; or**
 - D. Use a Restricted Rate designated by programmatic or statutory policy (see Notice of Funding Opportunity for Restricted Rate Programs).**
- 2a) Our Organizations currently has a Negotiated Indirect Cost Rate Agreement (NICRA) with the State of Illinois that will be accepted by all State of Illinois agencies up to any statutory, rule-based or programmatic restrictions or limitations. Our Organization is required to submit a new Indirect Cost Rate Proposal to the Indirect Cost Unit within six (6) months after the close of each fiscal year (2 CFR 200 Appendix IV (C)(2)(c)).

NOTE: (If this option is selected, please provide basic Indirect Cost Rate Agreement information in area designated below)

- 2b) Our unit of Local Government currently has a Federal Rate Maintained Internally (FRMI) with the State of Illinois that will be accepted by all State of Illinois agencies up to any statutory, rule-based or programmatic restrictions or limitations. Our unit of Local Government is required to submit a new State FRMI to the Indirect Cost Unit within six (6) months after the close of each fiscal year (2 CFR 200 Appendix VII (D)(1)(d)).

NOTE: (If this option is selected, please provide basic Indirect Cost Rate Agreement information in area designated below)

- 2c) Our Organization currently does not have a Negotiated Indirect Cost Rate Agreement (NICRA) with the State of Illinois. Our organization will submit our initial Indirect Cost Rate Proposal (ICRP) immediately after our Organization is advised that the State award will be made and, in no event, later than three (3) months after the effective date of the State award (2 CFR 200 Appendix IV (C)(2)(b)). The initial ICRP will be sent to the State of Illinois' Indirect Cost unit.

NOTE: (Check with your State of Illinois Agency for information regarding reimbursement of indirect costs while your proposal is being negotiated)

- 2d) Our unit of Local Government receives less than \$35 million in direct federal funding and currently does not have a Federal Rate Maintained Internally (FRMI) with the State of Illinois. Our unit of Local Government will complete the State FRMI submission immediately after our organization is advised that the State award will be made and, in no event, later than three (3) months after the effective date of the State award. The initial State FRMI will be sent to the State of Illinois' Indirect Cost unit.

NOTE: (Check with your State of Illinois Agency for information regarding reimbursement of indirect costs while your proposal is being negotiated)



State of Illinois
UNIFORM GRANT BUDGET TEMPLATE

Agreement Numbers. N/A

State Agency Illinois Department of Human Services

FY. 2025

Grantee Village of Forest Park

Notice of Funding Opportunity (NOFO) Number. N/A

Data Universal Number System (DUNS) Number 076891365

FEIN 366005875

Catalog of State Financial Assistance (CSFA) Number 444-26-1565

CSFA Short Description. TOBACCO ENFORCEMENT PROGRAM

Catalog of Federal Domestic Assistance (CFDA) Number N/A

CFDA Short Description. N/A

- 3) Our Organization elects to charge the de minimis rate of 10% modified total direct cost (MTDC) which may be used indefinitely on State of Illinois awards (2 CFR 200.414(f) & (200.1)).

NOTE: (Your Organization must be eligible, (see 2 CFR 200.414 (f), 2 CFR 200.VII (D)(1)(b), and 2 CFR 200.414(c)(1)) and submit documentation on the calculation of MTDC (2 CFR 200.1) within your Budget Narrative under Indirect Costs)

- 4) For Restricted Rate Programs, our Organization is using a restricted indirect cost rate that:
 - Is included as a "Special Indirect Cost Rate" in our NICRA (2 CFR 200 Appendix IV (B)(5)); Or
 - Complies with other statutory policies (please specify in the Narrative section of the Indirect Cost Category Page).
The Restricted Indirect Cost Rate is: N/A %
- 5) No reimbursement of Indirect Cost is being requested. (Please consult your program office regarding possible match requirements)

Basic Negotiated Indirect Cost Rate Agreement information if Option (1) or (2a) is selected

Period Covered by NICRA: From: N/A To: N/A (mm/dd/yyyy)

Approving Federal/State agency (please specify): N/A

The Indirect Cost Rate is N/A %

The Distribution Base is:

N/A



**State of Illinois
UNIFORM GRANT BUDGET TEMPLATE**

Agreement Number: N/A

State Agency Illinois Department of Human Services

FY. 2025

Grantee Village of Forest Park

Notice of Funding Opportunity (NOFO) Number: N/A

Data Universal Number System (DUNS) Number 076891365

FEIN 366005875

Catalog of State Financial Assistance (CSFA) Number 444-26-1565

CSFA Short Description. TOBACCO ENFORCEMENT PROGRAM

Catalog of Federal Domestic Assistance (CFDA) Number N/A

CFDA Short Description. N/A

Section B: Non-State of Illinois Funds

REVENUES	Total
Grantee Match Requirement %: <u>N/A</u>	
b) Cash	N/A
c) Non-Cash	N/A
d) other Funding and Contributions	N/A
Total Non-State Funds (lined b through d)	N/A
Budget Expenditure Categories	
1. Personnel (200.430)	N/A
2. Fringe Benefits (200.431)	N/A
3. Travel (200.475)	N/A
4. Equipment (200.439 and 200.436(a))	N/A
5. Supplies (200.1 and 200.453)	N/A
6. Contractual Services/Subawards (200.318 and 200.1)	N/A
7. Consultants (200.459)	N/A
8. Construction	N/A
9. Occupancy -Rent and Utilities (200.465 and 200.436(a))	N/A
10. Research and Development (R & D)(200.1)	N/A
11. Telecommunications	N/A
12. Training and Education (200.473)	N/A
13. Direct Administrative Costs (200.413)	N/A
14. Other or Miscellaneous Costs	N/A
15. Grant Exclusive Line Item(s)	N/A
16. Total Direct Costs (add lines 1-15)(200.413)	N/A
17. Indirect Cost (200.414)	N/A
Rate %: <u>N/A</u>	
Base: <u>N/A</u>	
18. Total Costs Non-State Grant Funds Lines 16 and 17 MUST EQUAL REVENUE TOTALS ABOVE	N/A



State of Illinois
UNIFORM GRANT BUDGET TEMPLATE

Agreement Number: N/A

State Agency Illinois Department of Human Services

FY. 2025

Grantee Village of Forest Park

Notice of Funding Opportunity (NOFO) Number: N/A

Data Universal Number System (DUNS) Number 076891365

FEIN 366005875

Catalog of State Financial Assistance (CSFA) Number 444-26-1565

CSFA Short Description. TOBACCO ENFORCEMENT PROGRAM

Catalog of Federal Domestic Assistance (CFDA) Number N/A

CFDA Short Description. N/A

By Signing this report, I certify to the best of my knowledge and belief that the report is true, complete and accurate and that any false, fictitious or fraudulent information or the omission of any material fact could result in the immediate termination of my grant award(s).

Note: The State Awarding Agency may change required signers based on the grantee's organizational structure. The required signers must have the authority to enter onto contractual agreements on the behalf of the organization.

Grantee Approval:

Budget version: 1.0.0 - Signed off as Executive Director and Submitted to program review by DORA MURPHY Admin Assist on 08/01/2024 01:45:24 PM



**State of Illinois
UNIFORM GRANT BUDGET TEMPLATE**

Agreement Numbers. N/A

State Agency Illinois Department of Human Services

FY. 2025

Grantee Village of Forest Park

Notice of Funding Opportunity (NOFO) Number. N/A

Data Universal Number System (DUNS) Number 076891365

FEIN 366005875

Catalog of State Financial Assistance (CSFA) Number 444-26-1565

CSFA Short Description. TOBACCO ENFORCEMENT PROGRAM

Catalog of Federal Domestic Assistance (CFDA) Number N/A

CFDA Short Description. N/A

FFATA Data Collection Form (if needed by agency)

Under FFATA, all sub-recipients who receive \$30,000 or more must provide the following information for federal reporting. Please fill out the following form accurately and completely.

4-digit extension if applicable:		
Sub-recipient DUNS:	076891365	Sub-recipient Parent Company DUNS:
Sub-recipient Name: <u>Village of Forest Park</u>		
Sub-recipient DBA Name: <u>Village of Forest Park</u>		
Sub-recipient Address: <u>517 Des Plaines Ave</u>		
City: <u>Forest Park</u>	State: <u>IL</u>	Zip-Code: <u>60130-1801</u> Congressional District: <u>07</u>
Sub-recipient Principal Place of Performance: <u>N/A</u>		
Sub-recipient Principal Place of Performance Street Address: <u>N/A</u>		
City: <u>N/A</u>	State: <u>N/A</u>	Zip-Code: <u>N/A</u> Congressional District:
Contract Number (if known): <u>N/A</u>		
Award Amount: <u>N/A</u>	Project Period: From: <u>N/A</u>	Project Period: To: <u>N/A</u>
State of Illinois Awarding Agency and Project Detail Description:		
<u>Retail Kit Distribution for 19 retailers and three compliance checks per retailer</u>		
Under certain circumstances, sub-recipient must provide names and total compensation of its top 5 highly compensated officials. Please answer the following questions and follow the instructions.		
Q1. In your business or organization's previous fiscal year, did your business or organization (including parent organization, all branches and affiliates worldwide) receive (1) 80% or more of your annual gross revenues in U.S. federal contracts, subcontracts, loans, grants, subgrants and/or cooperative agreements and (2) \$25,000,000 or more in annual gross revenue from U.S federal contracts, subcontracts, loans, grants, subgrants and/or cooperative agreements?		
Yes	<input type="checkbox"/>	If Yes, must answer Q2 below.
No	<input checked="" type="checkbox"/>	If No, you are not required to provide data.
Q2. Does the public have access to information about the compensation of the senior executives in your business or organization (including parent organization, all branches and all affiliates worldwide) through periodic reports filed under section 13(a) or 15(d) of the Security Exchange Act of 1934 (5 U.S.C. 78m(a), 78o(d)) or section 6104 of the Internal Revenue code of 1986 (i.e., on IRS Form 990)?		
Yes	<input type="checkbox"/>	
No	<input type="checkbox"/>	If No, you must provide the data. Please fill out the rest of this form.
Please provide names and total compensation of the top five officials:		
<u>N/A</u>		



**State of Illinois
UNIFORM GRANT BUDGET TEMPLATE**

Agreement Number: N/A

State Agency Illinois Department of Human Services

FY. 2025

Grantee Village of Forest Park

Notice of Funding Opportunity (NOFO) Number. N/A

Data Universal Number System (DUNS) Number 076891365

FEIN 366005875

Catalog of State Financial Assistance (CSFA) Number 444-26-1565

CSFA Short Description. TOBACCO ENFORCEMENT PROGRAM

Catalog of Federal Domestic Assistance (CFDA) Number N/A

CFDA Short Description. N/A

1). Personnel (2 CFR 200.430)

List each position by title and name of employee, if available. Show the annual salary rate and the percentage of time to be devoted to the project and length of time working on the project. Compensation paid for employees engaged in grant activities must be consistent with that paid for similar work within the applicant organization. Include a description of the responsibilities and duties of each position in relationship to fulfilling the project goals and objectives in the narrative space provided below. Also, provide a justification and description of each position (including vacant positions). Relate each position specifically to program objectives. Personnel cannot exceed 100% of their time on all active projects.

Name	Position	Salary Or Wage	Basis (Yr./Mo./Hr.)	% of Time	Length of Time	Personnel Cost
State: Item data NOT entered for this category						
					State Total	N/A
Non-State: Item data NOT entered for this category						
					Non-State Total	N/A
					Total Personnel	N/A

Personnel Narrative (State):

N/A

Personnel Narrative (Non-State): (i.e. "Match" or "Other Funding")

N/A



**State of Illinois
UNIFORM GRANT BUDGET TEMPLATE**

Agreement Number: N/A

State Agency Illinois Department of Human Services

FY. 2025

Grantee Village of Forest Park

Notice of Funding Opportunity (NOFO) Number: N/A

Data Universal Number System (DUNS) Number 076891365

FEIN 366005875

Catalog of State Financial Assistance (CSFA) Number 444-26-1565

CSFA Short Description. TOBACCO ENFORCEMENT PROGRAM

Catalog of Federal Domestic Assistance (CFDA) Number N/A

CFDA Short Description. N/A

2). Fringe Benefits (2 CFR 200.431)

Fringe benefits should be based on actual known costs or an established formula. Fringe benefits are for the personnel listed in category (1) direct salaries and wages, and only for the percentage of time devoted to the project. Provide the fringe benefit rate used and a clear description of how the computation of fringe benefits was done. Provide both the annual (for multiyear awards) and total. If a fringe benefit rate is not used, show how the fringe benefits were computed for each position. The budget justification should be reflected in the budget description. Elements that comprise fringe benefits should be indicated.

Name	Position(s)	Base	Rate (%)	Fringe Benefit Cost
State: Item data NOT entered for this category				
				State Total
				N/A
Non-State: Item data NOT entered for this category				
				Non-State Total
				N/A
				Total Fringe Benefits
				N/A

Fringe Benefits Narrative (State):

N/A

Fringe Benefits Narrative (Non-State): (i.e. "Match" or "Other Funding")

N/A



**State of Illinois
UNIFORM GRANT BUDGET TEMPLATE**

Agreement Number: N/A

State Agency Illinois Department of Human Services

FY. 2025

Grantee Village of Forest Park

Notice of Funding Opportunity (NOFO) Number: N/A

Data Universal Number System (DUNS) Number 076891365

FEIN 366005875

Catalog of State Financial Assistance (CSFA) Number 444-26-1565

CSFA Short Description. TOBACCO ENFORCEMENT PROGRAM

Catalog of Federal Domestic Assistance (CFDA) Number N/A

CFDA Short Description. N/A

3). Travel (2 CFR 200.475)

Travel should include: origin and destination, estimated costs and type of transportation, number of travelers, related lodging and per diem costs, brief description of the travel involved, its purpose, and explanation of how the proposed travel is necessary for successful completion of the project. In training projects, travel and meals for trainees should be listed separately. Show the number of trainees and unit cost involved. Identify the location of travel, if known, or if unknown, indicate "location to be determined." Indicate source of Travel Policies applied, Applicant or State of Illinois Travel Regulations. NOTE: Dollars requested in the travel category should be for staff travel only. Travel for consultants should be shown in the consultant category along with the consultant's fee. Travel for training participants, advisory committees, review panels and etc., should be itemized the same way as indicated above and placed in the "Miscellaneous" category

Name	Position	Cost Rate	Basis	Quantity	Number of Trips	Travel Cost
State: Item data NOT entered for this category						
					State Total	N/A
Non-State: Item data NOT entered for this category						
					Non-State Total	N/A
					Total Travel	N/A

Travel Narrative (State):

N/A

Travel Narrative (Non-State): (i.e. "Match" or "Other Funding")

N/A



**State of Illinois
UNIFORM GRANT BUDGET TEMPLATE**

Agreement Number: N/A

State Agency Illinois Department of Human Services

FY. 2025

Grantee Village of Forest Park

Notice of Funding Opportunity (NOFO) Number: N/A

Data Universal Number System (DUNS) Number 076891365

FEIN 366005875

Catalog of State Financial Assistance (CSFA) Number 444-26-1565

CSFA Short Description. TOBACCO ENFORCEMENT PROGRAM

Catalog of Federal Domestic Assistance (CFDA) Number N/A

CFDA Short Description. N/A

4. Equipment (200.439 and 200.436(a))

Provide justification for the use of each item and relate them to specific program objectives. Provide both the annual (for multiyear awards) and total for equipment. Equipment is defined as an article of tangible personal property that has a useful life of more than one year and a per-unit acquisition cost which equals or exceeds the lesser of the capitalization level established by the non-Federal entity for financial statement purposes, or \$5,000. An applicant organization may classify equipment at a lower dollar value but cannot classify it higher than \$5,000. (Note: The organization's own capitalization policy for classification of equipment must be used if the organization's capitalization threshold is less than \$5,000). Applicants should analyze the cost benefits of purchasing versus leasing equipment, especially high cost items and those subject to rapid technical advances. Rented or leased equipment costs should be listed in the "Contractual" category. Explain how the equipment is necessary for the success of the project. Attach a narrative describing the procurement method to be used.

Item	Quantity	Cost Per Item	Equipment Cost
State: Item data NOT entered for this category			
			State Total
			N/A
Non-State: Item data NOT entered for this category			
			Non-State Total
			N/A
			Total Equipment
			N/A

Equipment Narrative (State):

N/A

Equipment Narrative (Non-State): (i.e. "Match" or "Other Funding")

N/A



**State of Illinois
UNIFORM GRANT BUDGET TEMPLATE**

Agreement Number: N/A

State Agency Illinois Department of Human Services

FY. 2025

Grantee Village of Forest Park

Notice of Funding Opportunity (NOFO) Number: N/A

Data Universal Number System (DUNS) Number 076891365

FEIN 366005875

Catalog of State Financial Assistance (CSFA) Number 444-26-1565

CSFA Short Description: TOBACCO ENFORCEMENT PROGRAM

Catalog of Federal Domestic Assistance (CFDA) Number N/A

CFDA Short Description: N/A

5). Supplies (200.1 and 200.453)

List items by type (office supplies, postage, training materials, copying paper, and other expendable items such as books, hand held tape recorders) and show the basis for computation. Generally, supplies include any materials that are expendable or consumed during the course of the project.

Item	Quantity/Duration	Cost Per Item	Supplies Cost
State: Item data NOT entered for this category			
			State Total
			N/A
Non-State: Item data NOT entered for this category			
			Non-State Total
			N/A
			Total Supplies
			N/A

Supplies Narrative (State):

N/A

Supplies Narrative (Non-State): (i.e. "Match" or "Other Funding")

N/A



**State of Illinois
UNIFORM GRANT BUDGET TEMPLATE**

Agreement Number: N/A

State Agency Illinois Department of Human Services
Grantee Village of Forest Park

FY. 2025

Notice of Funding Opportunity (NOFO) Number: N/A

Data Universal Number System (DUNS) Number 076891365

FEIN 366005875

Catalog of State Financial Assistance (CSFA) Number 444-26-1565

CSFA Short Description. TOBACCO ENFORCEMENT PROGRAM

Catalog of Federal Domestic Assistance (CFDA) Number N/A

CFDA Short Description. N/A

6). Contractual Services (2 CFR 200.318) & Subawards (200.1)

Provide a description of the product or service to be procured by contract and an estimate of the cost. Applicants are encouraged to promote free and open competition in awarding contracts. A separate justification must be provided for sole contracts in excess of the Simplified Acquisition Threshold (SAT) (See 2 CFR 200.1).

NOTE: this budget category may include subawards. Provide separate budgets for each subaward or contract, regardless of the dollar value and indicate the basis for the cost estimates in the narrative. Describe products or services to be obtained and indicate the applicability or necessity of each to the project.

Please also note the differences between subaward, contract, and contractor (vendor):

- 1) Subaward (200.1) means an award provided by a pass-through entity to a subrecipient for the subrecipient to carry out part of a Federal/State award, including a portion of the scope of work or objectives. It does not include payments to a contractor or payments to an individual that is a beneficiary of a Federal/State program.
- 2) Contract (200.1) means a legal instrument by which a non-Federal entity purchases property or services needed to carry out the project or program under a Federal award. The term as used in this part does not include a legal instrument, even if the non-Federal entity considers it a contract, when the substance of the transaction meets the definition of a Federal award or subaward.
- 3) "Vendor" or "Contractor" is generally a dealer, distributor or other seller that provides supplies, expendable materials, or data processing services in support of the project activities.

Item	Contractual Services Cost
State: Item data NOT entered for this category	
State Total	N/A
Non-State: Item data NOT entered for this category	
Non-State Total	N/A
Total Contractual Services	N/A

Contractual Services & Subawards Narrative (State):

N/A

Contractual Services & Subawards Narrative (Non-State): (i.e. "Match" or "Other Funding")

N/A



**State of Illinois
UNIFORM GRANT BUDGET TEMPLATE**

Agreement Number: N/A

State Agency Illinois Department of Human Services

FY. 2025

Grantee Village of Forest Park

Notice of Funding Opportunity (NOFO) Number: N/A

Data Universal Number System (DUNS) Number 076891365

FEIN 366005875

Catalog of State Financial Assistance (CSFA) Number 444-26-1565

CSFA Short Description: TOBACCO ENFORCEMENT PROGRAM

Catalog of Federal Domestic Assistance (CFDA) Number N/A

CFDA Short Description: N/A

7). Consultant Services and Expenses (2 CFR 200.459)

Consultant Services (Fees): For each consultant enter the name, if known, service to be provided, hourly or daily fee (8-hour day), and estimated time on the project.

Consultant Services (Fees)	Services Provided	Fee	Basis	Quantity	Consultant Services (Fee) Cost	
State: Item data NOT entered for this category						
					State Total	N/A
Non-State: Item data NOT entered for this category						
					Non-State Total	N/A
					Total Consultant Services (Fees)	N/A

Consultant Services and Expenses Narrative (State):

N/A

Consultant Services and Expenses Narrative (Non-State): (i.e. "Match" or "Other Funding")

N/A



**State of Illinois
UNIFORM GRANT BUDGET TEMPLATE**

Agreement Number: N/A

State Agency Illinois Department of Human Services

FY. 2025

Grantee Village of Forest Park

Notice of Funding Opportunity (NOFO) Number: N/A

Data Universal Number System (DUNS) Number 076891365

FEIN 366005875

Catalog of State Financial Assistance (CSFA) Number 444-26-1565

CSFA Short Description: TOBACCO ENFORCEMENT PROGRAM

Catalog of Federal Domestic Assistance (CFDA) Number N/A

CFDA Short Description: N/A

7). Consultant Services and Expenses (2 CFR 200.459)

Consultant Expenses: List all expenses to be paid from the grant to the individual consultant in addition to their fees (i.e., travel, meals, lodging, etc.) Consultant-- Indicate whether applicant's formal, written Procurement Policy or the Federal Acquisitions Policy is used.

Consultant Expenses - Items	Location	Cost Rate	Basis	Quantity	Number of Trips	Consultant Expenses Cost
State: Item data NOT entered for this category						
						State Total
						N/A
Non-State: Item data NOT entered for this category						
						Non-State Total
						N/A
						Total Consultant Expenses
						N/A

Consultant Service and Expenses Narrative (State):

N/A

Consultant Service and Expenses Narrative (Non-State): (i.e. "Match" or "Other Funding")

N/A



**State of Illinois
UNIFORM GRANT BUDGET TEMPLATE**

Agreement Number: N/A

State Agency Illinois Department of Human Services

FY. 2025

Grantee Village of Forest Park

Notice of Funding Opportunity (NOFO) Number: N/A

Data Universal Number System (DUNS) Number 076891365

FEIN 366005875

Catalog of State Financial Assistance (CSFA) Number 444-26-1565

CSFA Short Description: TOBACCO ENFORCEMENT PROGRAM

Catalog of Federal Domestic Assistance (CFDA) Number N/A

CFDA Short Description: N/A

8). Construction

Provide a description of the construction project and an estimate of the costs. As a rule, construction costs are not allowable unless with prior written approval. In some cases, minor repairs or renovations may be allowable. Consult with the program office before budgeting funds in this category. Estimated construction costs must be supported by documentation including drawings and estimates, formal bids, etc. As with all other costs, follow the specific requirements of the program, the terms and conditions of the award, and applicable regulations.

Purpose	Description of Work	Construction Cost
State: Item data NOT entered for this category		
	State Total	N/A
Non-State: Item data NOT entered for this category		
	Non-State Total	N/A
	Total Construction	N/A

Construction Narrative (State):

N/A

Construction Narrative (Non-State): (i.e. "Match" or "Other Funding")

N/A



**State of Illinois
UNIFORM GRANT BUDGET TEMPLATE**

Agreement Number: N/A

State Agency Illinois Department of Human Services

FY. 2025

Grantee Village of Forest Park

Notice of Funding Opportunity (NOFO) Number: N/A

Data Universal Number System (DUNS) Number 076891365

FEIN 366005875

Catalog of State Financial Assistance (CSFA) Number 444-26-1565

CSFA Short Description: TOBACCO ENFORCEMENT PROGRAM

Catalog of Federal Domestic Assistance (CFDA) Number N/A

CFDA Short Description: N/A

9) Occupancy - Rent and Utilities (200.465 and 200.436(a))

List items and description by major type and the basis of the computation. Explain how direct charges for rental/depreciation and utility expenses are allocated for distribution as an expense to the program/service. For example, provide the square footage and the cost per square foot rent/depreciation, and utility, and provide a monthly rental/depreciation and utility cost and how many months to rent.
NOTE: This budgetary line item is to be used for direct program rent/depreciation and utilities, all other indirect or administrative occupancy costs should be listed in the indirect expense section of the Budget worksheet and narrative. Maintenance and repair costs may be included here if directly allocated to program.

Description	Quantity	Basis	Cost	Length of Time	Occupancy Cost
State: Item data NOT entered for this category					
					State Total
Non-State: Item data NOT entered for this category					
					Non-State Total
					Total Occupancy - Rent and Utilities

Occupancy Narrative (State):

N/A

Occupancy Narrative (Non-State): (i.e. "Match" or "Other Funding")

N/A



**State of Illinois
UNIFORM GRANT BUDGET TEMPLATE**

Agreement Number: N/A

State Agency Illinois Department of Human Services

FY. 2025

Grantee Village of Forest Park

Notice of Funding Opportunity (NOFO) Number: N/A

Data Universal Number System (DUNS) Number 076891365

FEIN 366005875

Catalog of State Financial Assistance (CSFA) Number 444-26-1565

CSFA Short Description: TOBACCO ENFORCEMENT PROGRAM

Catalog of Federal Domestic Assistance (CFDA) Number N/A

CFDA Short Description: N/A

10) Research and Development (R & D) (2 CFR 200.1)

Definition: All research activities, both basic and applied, and all development activities that are performed by non-Federal entities directed toward the production of useful materials, devices, systems, or methods, including design and development of prototypes and processes. Provide a description of the research and development project and an estimate of the costs. Consult with the program office before budgeting funds in this category.

Purpose	Description of Work	Research and Development Cost
State: Item data NOT entered for this category		
	State Total	N/A
Non-State: Item data NOT entered for this category		
	Non-State Total	N/A
	Total Research and Development	N/A

Research and Development Narrative (State):

N/A

Research and Development Narrative (Non-State): (i.e. "Match" or "Other Funding")

N/A



**State of Illinois
UNIFORM GRANT BUDGET TEMPLATE**

Agreement Number: N/A

State Agency Illinois Department of Human Services

FY. 2025

Grantee Village of Forest Park

Notice of Funding Opportunity (NOFO) Number: N/A

Data Universal Number System (DUNS) Number 076891365

FEIN 366005875

Catalog of State Financial Assistance (CSFA) Number 444-26-1565

CSFA Short Description: TOBACCO ENFORCEMENT PROGRAM

Catalog of Federal Domestic Assistance (CFDA) Number N/A

CFDA Short Description: N/A

11. Telecommunications

List items and descriptions by major type and the basis of the computation. Explain how telecommunication expenses are allocated for distribution as an expense to the program/service. NOTE: This budgetary line item is to be used for direct program telecommunications. All other indirect or administrative telecommunication costs should be listed in the indirect expense section of the Budget worksheet and narrative.

Description	Quantity	Basis	Cost	Length of Time	Telecommunications Cost
State: Item data NOT entered for this category					
State Total					N/A
Non-State: Item data NOT entered for this category					
Non-State Total					N/A
Total Telecommunications					N/A

Telecommunications Narrative (State):

N/A

Telecommunications Narrative (Non-State): (i.e. "Match" or "Other Funding")

N/A



**State of Illinois
UNIFORM GRANT BUDGET TEMPLATE**

Agreement Number: N/A

State Agency Illinois Department of Human Services

FY. 2025

Grantee Village of Forest Park

Notice of Funding Opportunity (NOFO) Number: N/A

Data Universal Number System (DUNS) Number 076891365

FEIN 366005875

Catalog of State Financial Assistance (CSFA) Number 444-26-1565

CSFA Short Description: TOBACCO ENFORCEMENT PROGRAM

Catalog of Federal Domestic Assistance (CFDA) Number N/A

CFDA Short Description: N/A

12) Training and Education (2 CFR 200.473)

Describe the training and education cost associated with employee development. Include rental space for training (if required), training materials, speaker fees, substitute teacher fees, and any other applicable expenses related to the training. When training materials (pamphlets, notebooks, videos, and other various handouts) are ordered for specific training activities, these items should be itemized below.

Description	Quantity	Basis	Cost	Length of Time	Training and Education Cost
State: Item data NOT entered for this category					
State Total					N/A
Non-State: Item data NOT entered for this category					
Non-State Total					N/A
Total Training and Education					N/A

Training and Education Narrative (State):

N/A

Training and Education Narrative (Non-State): (i.e. "Match" or "Other Funding")

N/A



**State of Illinois
UNIFORM GRANT BUDGET TEMPLATE**

Agreement Number: N/A

State Agency Illinois Department of Human Services

FY. 2025

Grantee Village of Forest Park

Notice of Funding Opportunity (NOFO) Number: N/A

Data Universal Number System (DUNS) Number 076891365

FEIN 366005875

Catalog of State Financial Assistance (CSFA) Number 444-26-1565

CSFA Short Description. TOBACCO ENFORCEMENT PROGRAM

Catalog of Federal Domestic Assistance (CFDA) Number N/A

CFDA Short Description. N/A

13). Direct Administrative Costs (2 CFR 200.413)

The salaries of administrative and clerical staff should normally be treated as indirect (F&A) costs. Direct charging of these costs may be appropriate only if all of the following conditions are met: (1) Administrative or clerical services are integral to a project or activity; (2) Individuals involved can be specifically identified with the project or activity; (3) Such costs are explicitly included in the budget or have the prior written approval of the State awarding agency; and (4) The costs are not also recovered as indirect costs.

Name	Position	Salary Or Wage	Basis (Yr./Mo./Hr.)	% of Time	Length of Time	Direct Administrative Cost
State: Item data NOT entered for this category						
						State Total
						N/A
Non-State: Item data NOT entered for this category						
						Non-State Total
						N/A
						Total Direct Administrative Costs
						N/A

Direct Administrative Costs Narrative (State):

N/A

Direct Administrative Costs Narrative (Non-State): (i.e. "Match" or "Other Funding")

N/A



**State of Illinois
UNIFORM GRANT BUDGET TEMPLATE**

Agreement Number: N/A

State Agency Illinois Department of Human Services

FY. 2025

Grantee Village of Forest Park

Notice of Funding Opportunity (NOFO) Number: N/A

Data Universal Number System (DUNS) Number 076891365

FEIN 366005875

Catalog of State Financial Assistance (CSFA) Number 444-26-1565

CSFA Short Description: TOBACCO ENFORCEMENT PROGRAM

Catalog of Federal Domestic Assistance (CFDA) Number N/A

CFDA Short Description: N/A

14) Other or Miscellaneous Costs

This category contains items not included in the previous categories. List items by type of material or nature of expense, break down costs by quantity and cost per unit if applicable, state the necessity of other costs for successful completion of the project and exclude unallowable costs (eg. Printing, Memberships & subscriptions, recruiting costs, etc.)

Description	Quantity	Basis	Cost	Length of Time	Other or Miscellaneous Cost
State: Item data NOT entered for this category					
State Total					N/A
Non-State: Item data NOT entered for this category					
Non-State Total					N/A
Total Other or Miscellaneous Costs					N/A

Other or Miscellaneous Costs Narrative (State):

N/A

Other or Miscellaneous Costs Narrative (Non-State): (i.e. "Match" or "Other Funding")

N/A



**State of Illinois
UNIFORM GRANT BUDGET TEMPLATE**

Agreement Number: N/A

State Agency Illinois Department of Human Services

FY. 2025

Grantee Village of Forest Park

Notice of Funding Opportunity (NOFO) Number: N/A

Data Universal Number System (DUNS) Number 076891365

FEIN 366005875

Catalog of State Financial Assistance (CSFA) Number 444-26-1565

CSFA Short Description: TOBACCO ENFORCEMENT PROGRAM

Catalog of Federal Domestic Assistance (CFDA) Number N/A

CFDA Short Description: N/A

15). Grant Exclusive Line Item(s)

Grant Exclusive Line Item Description: Retailer Kit Distribution and Compliance Checks

Costs directly related to the service or activity of the program that is an integral line item for budgetary purposes. To use this budgetary line item, an applicant must have Program approval. (Please cite reference per statute for unique costs directly related to the service or activity of the program).

Description	Quantity	Basis	Cost	Length of Time	Grant Exclusive Line Item Cost
Retailer Kit Distribution	19.000	yearly	\$1,045.000	1.000	\$1,045.000
Compliance Checks	57.000	yearly	\$2,052.000	1.000	\$2,052.000
Record Maintenance Fee	19.000	yearly	\$310.000	1.000	\$310.000
State Total					\$3,407.00
Non-State: Item data NOT entered for this category					
Non-State Total					
Total Grant Exclusive Line Item(s)					\$3,407.00

Grant Exclusive Line Item Narrative (State):

Retailer Kit Distribution for 19 retailers and 3 compliance checks

Grant Exclusive Line Item Narrative (Non-State): (i.e. "Match" or "Other Funding")



**State of Illinois
UNIFORM GRANT BUDGET TEMPLATE**

Agreement Number: N/A

State Agency Illinois Department of Human Services

FY. 2025

Grantee Village of Forest Park

Notice of Funding Opportunity (NOFO) Number. N/A

Data Universal Number System (DUNS) Number 076891365

FEIN 366005875

Catalog of State Financial Assistance (CSFA) Number 444-26-1565

CSFA Short Description. TOBACCO ENFORCEMENT PROGRAM

Catalog of Federal Domestic Assistance (CFDA) Number N/A

CFDA Short Description. N/A

16). Indirect Cost (2 CFR 200.414)

Provide the most recent indirect cost rate agreement information with the itemized budget. The applicable indirect cost rate(s) negotiated by the organization with the cognizant negotiating agency must be used in computing indirect costs (F&A) for a program budget. The amount for indirect costs should be calculated by applying the current negotiated indirect cost rate(s) to the approved base(s). After the amount of indirect costs is determined for the program, a breakdown of the indirect costs should be provided in the budget worksheet and narrative below.

Description	Base	Rate (%)	Indirect Cost
State: Option 6 - No reimbursement of Indirect Cost is being requested. (See Indirect Cost Rate Information.)			
State Total			N/A
Non-State: Option 6 - No reimbursement of Indirect Cost is being requested. (See Indirect Cost Rate Information.)			
Non-State Total			N/A
Total Indirect Cost			N/A

Indirect Cost Narrative (State):

N/A

Indirect Cost Narrative (Non-State):

N/A



**State of Illinois
UNIFORM GRANT BUDGET TEMPLATE**

Agreement Number: N/A

State Agency Illinois Department of Human Services

FY. 2025

Grantee Village of Forest Park

Notice of Funding Opportunity (NOFO) Number: N/A

Data Universal Number System (DUNS) Number 076891365

FEIN 366005875

Catalog of State Financial Assistance (CSFA) Number 444-26-1565

CSFA Short Description. TOBACCO ENFORCEMENT PROGRAM

Catalog of Federal Domestic Assistance (CFDA) Number N/A

CFDA Short Description. N/A

Budget Narrative Summary

When you have completed the budget Category pages, the totals for each category should appear in the corresponding rows below. Additionally, the amount of State requested funds and non-State funds that will support the project are also listed. Verify the amounts and the Total Project Costs.

Budget Category	State	Non-State	Total
1. Personnel	N/A	N/A	N/A
2. Fringe Benefits	N/A	N/A	N/A
3. Travel	N/A	N/A	N/A
4. Equipment	N/A	N/A	N/A
5. Supplies	N/A	N/A	N/A
6. Contractual Services	N/A	N/A	N/A
7. Consultant (Professional Services)	N/A	N/A	N/A
8. Construction	N/A	N/A	N/A
9. Occupancy (Rent and Utilities)	N/A	N/A	N/A
10. Research and Development (R & D)	N/A	N/A	N/A
11. Telecommunications	N/A	N/A	N/A
12. Training and Education	N/A	N/A	N/A
13. Direct Administrative Costs	N/A	N/A	N/A
14. Other or Miscellaneous Costs	N/A	N/A	N/A
15. GRANT EXCLUSIVE LINE ITEM(S)	\$3,407.00	N/A	\$3,407.00
16. Total Direct Costs (add lines 1-15) (200.413)	\$3,407.00	N/A	\$3,407.00
17. Indirect Cost	N/A	N/A	N/A
State Request	\$3,407.00		
Non-State Amount		N/A	
TOTAL PROJECT COSTS			\$3,407.00



**State of Illinois
UNIFORM GRANT BUDGET TEMPLATE**

Agreement Number: N/A

State Agency Illinois Department of Human Services

FY. 2025

Grantee Village of Forest Park

Notice of Funding Opportunity (NOFO) Number: N/A

Data Universal Number System (DUNS) Number 076891365

FEIN 366005875

Catalog of State Financial Assistance (CSFA) Number 444-26-1565

CSFA Short Description. TOBACCO ENFORCEMENT PROGRAM

Catalog of Federal Domestic Assistance (CFDA) Number N/A

CFDA Short Description. N/A

For STATE Use Only:

Initial Budget Request Amount: \$3,407.00

Prior Written Approval for Expense Line Item: N/A

Statutory Limits or Restrictions: N/A

Checklist: N/A

Final Budget Amount Approved: \$0.00

Program Approval:

--Awaiting Signatures--

Fiscal & Administrative Approval:

--Awaiting Signatures--

Budget Revision Approved:

Program Approval:

Fiscal & Administrative Approval:

200.308 Revision of budget and program plans

(e) The Federal/State awarding agency may, at its option, restrict the transfer of funds among direct cost categories or programs, functions and activities for Federal/State awards in which the Federal/State share of the project exceeds the Simplified Acquisition Threshold and the cumulative amount of such transfers exceeds or is expected to exceed 10 percent or \$1,000 per detail line item, whichever is greater of the total budget as last approved by the Federal/State awarding agency. The Federal/State awarding agency cannot permit a transfer that would cause any Federal/State appropriation to be used for purposes other than those consistent with the appropriation.

**A RESOLUTION RE-APPROVING THE SPECIFICATIONS
AND RE-AUTHORIZING THE ADVERTISING OF BIDS
FOR THE VILLAGE OF FOREST PARK
2024 LEAD SERVICE REPLACEMENT PROJECT**

WHEREAS, the Village of Forest Park ("Village") has undertaken to develop updated plans and specifications for the 2024 Lead Service Replacement Project (the "Project") in the Village; and

WHEREAS, the Village desires to re-approve certain, guidelines, plans, specifications and advertisement for bids for the Project.

BE IT RESOLVED, by the Mayor and Village Council of the Village of Forest Park, Cook County, Illinois, as follows:

Section 1. Finding of the Corporate Authorities

In the opinion of a majority of the corporate authorities of the Village, it is advisable, necessary and in the public interest that the Village re-approve the specifications for, advertise for bids and solicit bids for the Project.

Section 2. Advertisement for Bids

The Village Clerk and Village Engineer, Christopher B. Burke Engineering, Ltd., are hereby authorized and directed to cause an advertisement and to solicit bids, pursuant to the public bid process and in substantially the form of the Local Public Agency Formal Contract Proposal for the Project, attached hereto as Exhibit "A" and made a part hereof.

Section 3. Effective Date

This Resolution shall be in full force and effect from and after its passage and approval in the manner provided by law.

ADOPTED by the Council of the Village of Forest Park, Cook County, Illinois this 12th
day of August, 2024.

AYES: _____

NAYS: _____

ABSENT: _____

APPROVED by me this 12th day of August, 2024.

Rory E. Hoskins, Mayor

ATTESTED and filed in my office,
and published in pamphlet form
this _____ day of August, 2024.

Vanessa Belmonte, Village Clerk

EXHIBIT "A"

**Updated 2024 Lead Service Replacement Project
Local Public Agency Formal Contract Proposal**

**Local Public Agency
Formal Contract Proposal**

COVER SHEET

Proposal Submitted By:

Contractor's Name

Contractor's Address

City

State

Zip Code

STATE OF ILLINOIS

Local Public Agency

County

Section Number

Route(s) (Street/Road Name)

Type of Funds

Proposal Only Proposal and Plans Proposal only, plans are separate

Submitted/Approved

For Local Public Agency:

Note: All proposal documents, including Proposal Guaranty Checks or Proposal Bid Bonds, should be stapled together to prevent loss when bids are processed.

Local Public Agency	County	Section Number	Route(s) (Street/Road Name)
Village of Forest Park	Cook		Forest Park Lead Service Repl

NOTICE TO BIDDERS

Sealed proposals for the project described below will be received at the office of Village of Forest Park
 Name of Office
517 Des Plaines Ave, Forest Park, IL 60130 until 10:00 AM on 08/27/24
 Address Time Date

Sealed proposals will be opened and read publicly at the office of Village of Forest Park
 Name of Office
517 Des Plaines Ave, Forest Park, IL 60130 at 10:00 AM on 08/27/24
 Address Time Date

DESCRIPTION OF WORK

Location	Project Length
Various Streets (See Location Map)	N/A

Proposed Improvement
 Lead water service replacements from the B-Box into the interior of the various buildings and all necessary restoration to complete the work.

1. Plans and proposal forms will be available in the office of
<http://cbbel.com/bidding-info/> or at www.questcdn.com
 Under Login using QuestCDN #XXXXXXX for a non-refundable charge of \$50.00. A login will be required.

2. Prequalification
 If checked, the 2 apparent as read low bidders must file within 24 hours after the letting an "Affidavit of Availability" (Form BC 57) in triplicate, showing all uncompleted contracts awarded to them and all low bids pending award for Federal, State, County, Municipal and private work. One original shall be filed with the Awarding Authority and two originals with the IDOT District Office.
3. The Awarding Authority reserves the right to waive technicalities and to reject any or all proposals as provided in BLRS Special Provision for Bidding Requirements and Conditions for Contract Proposals.
4. The following BLR Forms shall be returned by the bidder to the Awarding Authority:
 - a. Local Public Agency Formal Contract Proposal (BLR 12200)
 - b. Schedule of Prices (BLR 12201)
 - c. Proposal Bid Bond (BLR 12230) (if applicable)
 - d. Apprenticeship or Training Program Certification (BLR 12325) (do not use for project with Federal funds.)
 - e. Affidavit of Illinois Business Office (BLR 12326) (do not use for project with Federal funds)
5. The quantities appearing in the bid schedule are approximate and are prepared for the comparison of bids. Payment to the Contractor will be made only for the actual quantities of work performed and accepted or materials furnished according to the contract. The scheduled quantities of work to be done and materials to be furnished may be increased, decreased or omitted as hereinafter provided.
6. Submission of a bid shall be conclusive assurance and warranty the bidder has examined the plans and understands all requirements for the performance of work. The bidder will be responsible for all errors in the proposal resulting from failure or neglect to conduct an in depth examination. The Awarding Authority will, in no case, be responsible for any costs, expenses, losses or changes in anticipated profits resulting from such failure or neglect of the bidder.
7. The bidder shall take no advantage of any error or omission in the proposal and advertised contract.
8. If a special envelope is supplied by the Awarding Authority, each proposal should be submitted in that envelope furnished by the Awarding Agency and the blank spaces on the envelope shall be filled in correctly to clearly indicate its contents. When an envelope other than the special one furnished by the Awarding Authority is used, it shall be marked to clearly indicate its contents. When sent by mail, the sealed proposal shall be addressed to the Awarding Authority at the address and in care of the official in whose office the bids are to be received. All proposals shall be filed prior to the time and at the place specified in the Notice to Bidders. Proposals received after the time specified will be returned to the bidder unopened.
9. Permission will be given to a bidder to withdraw a proposal if the bidder makes the request in writing or in person before the time for opening proposals.

Local Public Agency	County	Section Number	Route(s) (Street/Road Name)
Village of Forest Park	Cook		Forest Park Lead Service Repla

PROPOSAL

1. Proposal of _____ Contractor's Name _____

Contractor's Address _____

2. The plans for the proposed work are those prepared by _____ and approved by the Department of Transportation on _____.

3. The specifications referred to herein are those prepared by the Department of Transportation and designated as "Standard Specifications for Road and Bridge Construction" and the " Supplemental Specifications and Recurring Special Provisions" thereto, adopted and in effect on the date of invitation for bids.

4. The undersigned agrees to accept, as part of the contract, the applicable Special Provisions indicated on the "Check Sheet for Recurring Special Provisions" contained in this proposal.

5. The undersigned agrees to complete the work within _____ working days or by 05/01/25 unless additional time is granted in accordance with the specifications.

6. The successful bidder at the time of execution of the contract will be required to deposit a contract bond for the full amount of the award. When a contract bond is not required, the proposal guaranty check will be held in lieu thereof. If this proposal is accepted and the undersigned fails to execute a contract and contract bond as required, it is hereby agreed that the Bid Bond of check shall be forfeited to the Awarding Authority.

7. Each pay item should have a unit price and a total price. If no total price is shown or if there is a discrepancy between the products of the unit price multiplied by the quantity, the unit price shall govern. If a unit price is omitted, the total price will be divided by the quantity in order to establish a unit price. A bid may be declared unacceptable if neither a unit price nor a total price is shown.

8. The undersigned submits herewith the schedule of prices on BLR 12201 covering the work to be performed under this contract.

9. The undersigned further agrees that if awarded the contract for the sections contained in the combinations on BLR 12201, the work shall be in accordance with the requirements of each individual proposal for the multiple bid specified in the Schedule for Multiple Bids below.

10. A proposal guaranty in the proper amount, as specified in BLRS Special Provision for Bidding Requirements and Conditions for Contract Proposals, will be required. Bid Bonds will be allowed as a proposal guaranty. Accompanying this proposal is either a bid bond, if allowed, on Department form BLR 12230 or a proposal guaranty check, complying with the specifications, made payable to: Village Treasurer of Forest Park.

The amount of the check is _____ (_____).

Attach Cashier's Check or Certified Check Here

In the event that one proposal guaranty check is intended to cover two or more bid proposals, the amount must be equal to the sum of the proposal guaranties which would be required for each individual bid proposal. If the proposal guaranty check is placed in another bid proposal, state below where it may be found.

The proposal guaranty check will be found in the bid proposal for: Section Number _____.

Local Public Agency	County	Section Number	Route(s) (Street/Road Name)
Village of Forest Park	Cook		Forest Park Lead Service Repla

CONTRACTOR CERTIFICATIONS

The certifications hereinafter made by the bidder are each a material representation of fact upon which reliance is placed should the Department enter into the contract with the bidder.

- Debt Delinquency.** The bidder or contractor or subcontractor, respectively, certifies that it is not delinquent in the payment of any tax administered by the Department of Revenue unless the individual or other entity is contesting, in accordance with the procedure established by the appropriate Revenue Act, its liability for the tax or the amount of the tax. Making a false statement voids the contract and allows the Department to recover all amounts paid to the individual or entity under the contract in a civil action.
- Bid-Rigging or Bid Rotating.** The bidder or contractor or subcontractor, respectively, certifies that it is not barred from contracting with the Department by reason of a violation of either 720 ILCS 5/33E-3 or 720 ILCS 5/33E-4.

A violation of section 33E-3 would be represented by a conviction of the crime of bid-rigging which, in addition to Class 3 felony sentencing, provides that any person convicted of this offense, or any similar offense of any state or the United States which contains the same elements as this offense shall be barred for 5 years from the date of conviction from contracting with any unit of State or local government. No corporation shall be barred from contracting with any unit of State or local government as a result of a conviction under this Section of any employee or agent of such corporation if the employee so convicted is no longer employed by the corporation: (1) it has been finally adjudicated not guilty or (2) if it demonstrates to the governmental entity with which it seeks to contract that entity finds that the commission of the offense was neither authorized, requested, commanded, nor performed by a director, officer or a high managerial agent on behalf of the corporation.

A violation of Section 33E-4 would be represented by a conviction of the crime of bid-rotating which, in addition to Class 2 felony sentencing, provides that any person convicted of this offense or any similar offense of any state or the United States which contains the same elements as this offense shall be permanently barred from contracting with any unit of State of Local government. No corporation shall be barred from contracting with any unit of State or Local government as a result of a conviction under this Section of any employee or agent of such corporation if the employee so convicted is no longer employed by the corporation and: (1) it has been finally adjudicated not guilty or (2) if it demonstrates to the governmental entity with which it seeks to contract and that entity finds that the commission of the offense was neither authorized, requested, commanded, nor performed by a director, officer or a high managerial agent on behalf of the corporation.

- Bribery.** The bidder or contractor or subcontractor, respectively, certifies that, it has not been convicted of bribery or attempting to bribe an officer or employee of the State of Illinois or any unit of local government, nor has the firm made an admission of guilt of such conduct which is a matter or record, nor has an official, agent, or employee of the firm committed bribery or attempted bribery on behalf of the firm and pursuant to the direction or authorization of a responsible official of the firm.
- Interim Suspension or Suspension.** The bidder or contractor or subcontractor, respectively, certifies that it is not currently under a suspension as defined in Subpart I of Title 44 Subtitle A Chapter III Part 6 of the Illinois Administrative code. Furthermore, if suspended prior to completion of this work, the contract or contracts executed for the completion of this work may be canceled.

Schedule of Prices

Contractor's Name			
Contractor's Address		City	State Zip Code
Local Public Agency		County	Section Number
Village of Forest Park		Cook	
Route(s) (Street/Road Name)			
Various			

Schedule for Multiple Bids		
Combination Letter	Section Included in Combinations	Total
Base Bid		

Schedule for BASE BID						
(For complete information covering these items, see plans and specifications.)						
No.	Item Code	Items	Unit	Quantity	Unit Price	Total
1	20101100	TREE TRUNK PROTECTION	EACH	55		
2	20101200	TREE ROOT PRUNING	EACH	55		
3	25200200	SUPPLEMENTAL WATERING	UNIT	10		
4	67100100	MOBILIZATION	L SUM	1		
5	70102620	TRAFFIC CONTROL AND PROTECTION, STANDARD 701501	L SUM	1		
6	*X0320050	CONSTRUCTION LAYOUT (SPECIAL)	L SUM	1		
7	*N/A	ITEMS ORDERED BY ENGINEER	EACH	30,000	\$1	\$30,000.00
8	*N/A	VIDEO TAPING (INTERIOR AND EXTERIOR)	L SUM	1		
9	*N/A	WATER SERVICE INTERIOR RESTORATION	EACH	327		
10	*N/A	REPLACEMENT B-BOXES	EACH	10		
11	*N/A	WATER SERVICE LINE (PRIVATE) - LEAD SERVICE REPLACEMENT, 1"	EACH	318		
12	*N/A	WATER SERVICE LINE (PRIVATE) - LEAD SERVICE REPLACEMENT, 1.5"	EACH	9		
Bidder's Total Proposal (Base Bid):						

BIDDER'S TOTAL AMOUNT IN WORDS FOR BASE BID

1. Each pay item should have a unit price and a total price.
2. If no total price is shown or if there is a discrepancy between the product of the unit price multiplied by the quantity, the unit price shall govern.
3. If a unit price is omitted, the total price will be divided by the quantity in order to establish a unit price.
4. A bid may be declared unacceptable if neither a unit price or total price is shown.

Schedule of Prices

Contractor's Name			
Contractor's Address		City	State Zip Code
Local Public Agency		County	Section Number
Village of Forest Park		Cook	
Route(s) (Street/Road Name)			
Various			

Schedule for Multiple Bids		
Combination Letter	Section Included in Combinations	Total
Base Bid + Alternate 1		

Schedule for BASE BID + ALTERNATE 1
(For complete information covering these items, see plans and specifications.)

No.	Item Code	Items	Unit	Quantity	Unit Price	Total
1	20101100	TREE TRUNK PROTECTION	EACH	65		
2	20101200	TREE ROOT PRUNING	EACH	65		
3	25200200	SUPPLEMENTAL WATERING	UNIT	14		
4	67100100	MOBILIZATION	L SUM	1		
5	70102620	TRAFFIC CONTROL AND PROTECTION, STANDARD 701501	L SUM	1		
6	*X0320050	CONSTRUCTION LAYOUT (SPECIAL)	L SUM	1		
7	*N/A	ITEMS ORDERED BY ENGINEER	EACH	35,000	\$1	\$35,000.00
8	*N/A	VIDEO TAPING (INTERIOR AND EXTERIOR)	L SUM	1		
9	*N/A	WATER SERVICE INTERIOR RESTORATION	EACH	369		
10	*N/A	REPLACEMENT B-BOXES	EACH	10		
11	*N/A	WATER SERVICE LINE (PRIVATE) - LEAD SERVICE REPLACEMENT, 1"	EACH	357		
12	*N/A	WATER SERVICE LINE (PRIVATE) - LEAD SERVICE REPLACEMENT, 1.5"	EACH	12		
Bidder's Total Proposal (Base Bid + Alternate 1):						

BIDDER'S TOTAL AMOUNT IN WORDS FOR BASE BID + ALTERNATE 1

1. Each pay item should have a unit price and a total price.
2. If no total price is shown or if there is a discrepancy between the product of the unit price multiplied by the quantity, the unit price shall govern.
3. If a unit price is omitted, the total price will be divided by the quantity in order to establish a unit price.
4. A bid may be declared unacceptable if neither a unit price or total price is shown.

Local Public Agency	County	Section Number	Route(s) (Street/Road Name)
Village of Forest Park	Cook		Forest Park Lead Service Repla

SIGNATURES

(If an individual)

Bidder Signature & Date

Business Address

City State Zip Code

(If a partnership)

Firm Name

Signature & Date

Title

Business Address

City State Zip Code

Insert the Names and Addresses of all Partners

(If a corporation)

Corporate Name

Signature & Date

Title

Business Address

City State Zip Code

Insert Names of Officers

President

Attest:

Secretary

Secretary

Treasurer

**Illinois Environmental Protection Agency – Public Water Supply Loan Program (PWSLP)
Loan Applicant’s Certification of Plans/Specifications Compliance with PWSLP Rules
(Rev 04/2023)**

Loan Applicant: Village of Forest ParkL17# 6160

Project Description:

Private water service replacement from B-Box into residential houses and all necessary
restoration.

Section I – Loan Program Requirements

Provide page number(s) for location of the information below in the bidding documents/specifications.

Page #'s

1. 12 Advertisement for Bids includes notification to bidders that procurement is subject to regulations contained in the IEPA loan program rules, the Davis-Bacon Act (40 USC 276a through 276a-5), the Employment of IL Workers on Public Works Act, IL Works Jobs Program Act (Apprenticeship Initiative), DBE Policy per 40 CFR Part 33, as amended, and the “Build America, Buy America Act” requirements as contained in the federal Infrastructure Investment and Jobs Act, Pub. L. No. 117-58. [Loan Rules Section 662.620(b)].
2. 2 Sealed Bids are required.
3. 2 Public bid opening will be held.
4. 13 Method of bid evaluation. In accordance with Section 662.620(c)(3).
5. 13 Criteria for evaluating bidders in accordance with Section 662.620(c)(5).
6. 13 Bidders can modify/withdraw bids prior to opening.
7. 12+14 Award shall be made to the low, responsive, responsible bidder in accordance with Section 662.620(e)(3)(4).
8. 15 Non-collusion and certification statement in accordance with Section 662.620(c)(6). Language is attached. See attached page 9, I and II.
9. 3+13 Minimum 5% bid bond in accordance with Section 662.620(e)(2)(f).
10. 13 100% performance/payment bonds in accordance with Section 662.420(b)(1).
11. 72 Equal Opportunity Clauses and Information per federal Executive Order 11246.
12. 89 Disadvantaged Business Enterprise (DBE) provisions per 40 CFR Part 33.
13. 92 DBE specifications and forms. A DBE guidance package is available on the IEPA website.
14. 58 The Non-Discrimination Clause is contained within the contract 662.620 (f)(8). See Item 7, page 22 of the attached document.
15. 23 Davis-Bacon Wage Act language, wages and clauses are included in the bidding documents and specifications. Contractor(s) shall pay prevailing wages at rates not less than those prevailing under the Davis-Bacon Wage Act.
16. 84 Change orders: method for handling is in accordance with Section 662.420(b)(2).
17. 84 Audit; access to records provision in accordance with Section 662.620(f)(1)(A-G).
18. 86 Covenant against contingent fee provision in accordance with Section 662.620(f)(2).
19. 82 “Certification Regarding Debarment, Suspension and other Responsibility Matters USEPA Form 5700-49” or equivalent contract language in accordance with Section 662.620(f)(5).
20. 87 Contracts for Subcontractors will be in accordance with Section 662.620(g).
21. 87 Contractor Bankruptcy clause in accordance with Section 662.620(h).
22. 87 Remedies per Section 662.640(c).
23. 87 Access to work site allowed per Section 662.620(i).
24. N/A Substantial Completion (project is operational) specified: _____ calendar days
25. 118 Final Completion (if applicable) specified: December 1st, 2024 calendar days
26. 88 Certification regarding Compliance with Criminal Code of 2012. [Section 662.620(c)(6)(A)(iii)].

- 27. 64 Notice of Intent to Award form [Section 662.620(e)(2)(E)].
- 28. 65 Notice of Award Form.
- 29. 66 Notice to Proceed Form.
- 30. 67 Change Order Form.
- 31. 80 Certification of Nonsegregated Facilities Form [Section 662.620(f)(6)].
- 32. 81 Nondiscrimination in Employment Notice per federal Executive Order 11246.
- 33. 82 Certification Regarding Debarment, Suspension & other Responsibility Matters [Section 662.620(f)(5)].
- 34. N/A Experience Clause requirements, if utilized, are justified in submittal dated _____.
Section 662.620(c)(5).
- 35. 98 Certification that all iron, steel, manufactured products, & construction materials used in the project are produced in the United States per the federal ~~Build America, Buy America~~ Act [Pub. L. No. 117-58, §§ 70901-52]. AIS
- 36. 102 IL Works Jobs Program Act (Apprenticeship Initiative) Information [30 ILCS 559/20/20-1]
- 37. N/A Pre-negotiated prices if utilized. The loan rules require formal advertising and competitive bidding of construction contracts. Items must be procured in accordance with Section 662.620.

Section II – Approved Scope of Work

The PWSLP can only provide funding for the project scope approved in the Project Plan. ALL changes must be explained and justified in writing and receive Agency approval. Changes to the approved scope of work may require a Project Plan amendment.

YES **NO** Plans and specifications have been prepared consistent with the Project Plan approved by the Agency in a letter dated MARCH 31, 2023. If any changes have been made to the scope of the project after planning approval, please identify below (include attachments with a detailed narrative of any changes if necessary): _____
(Circle One)

Section III – Loan Eligibility

In general, extended warranties, spare parts, and allowances are not eligible to receive loan funding. If this project includes any Warranties, Spare Parts, Allowances or other possible ineligible items, provide an explanation and the page number in the bidding documents where the ineligible item is located.

1. **Warranties:** The Loan Program can only fund the normal industry standard warranty. Any extended, special, or additional warranties are not eligible in the loan program. If any warranty is more than the industry standard, please provide the cost for the warranty in excess of the industry standard.

Does this project include the purchase of any extended warranties? YES or NO (Circle One)
If YES, provide the page number and an explanation.

2. **Spare Parts:** Spare parts and extra materials are normally not loan eligible as they are viewed as maintenance related. To be eligible, spare parts must be justified as critical parts of major system components which are not immediately available and/or whose procurement involves an extended lead time.

Does this project include the purchase of any spare parts? YES or NO (Circle One)
If YES, provide the page number and an explanation.

3. **Allowances** (a fixed price to perform a specific scope of work) may be eligible at the time of the loan award provided justification for the allowance(s) is provided to the Agency along with a description of the scope of work and the basis for the establishment of the allowance amount. **Allowances are not allowed for equipment purchases which must be competitively bid.**

Does this project include any allowances? YES or NO (Circle One)
If YES, provide the page number for each allowance along with an explanation. PAGE 126

WE HAVE INCLUDED AN "ITEMS TO BE ORDERED BY THE ENGINEER" ALLOWANCE FOR ANY UNFORESEEN RESTORATION.

4. **Site Restoration:** The loan program can only fund site restoration to pre-construction conditions. For underground work, restoration is normally limited to the width of the trench. Costs for any site restoration beyond pre-construction conditions or for work outside the width of the trench should be identified.

Does this project include any restoration costs above and beyond pre-construction conditions?

YES or NO (Circle One)

If YES, provide the page number and an explanation.

5. **Does the project include other items that may be ineligible?** Examples include costs outside the project scope, costs considered normal operating expenses, and pre-negotiated prices (see item 38).

YES or NO (Circle One)

If YES, provide the page number and an explanation.

<p>METHODS UTILIZED TO ADDRESS INELIGIBLE ITEMS IN PWSLP PROJECTS</p> <ol style="list-style-type: none"> 1. Delete ineligible items from the project. 2. Provide a separate line item in the bid for ineligible items. 3. Proration of bid for the percentage of ineligible cost(s). 4. Agreement on costs between the Agency and borrower prior to bidding.

Section IV – Environmental Conditions

YES or NO (Circle One)

If YES, provide the page number(s). *WE HAVE INCLUDED IDNR PERMIT #3 ON PAGES 120-126*
If environmental review of this project resulted in recommendations or conditions to utilize mitigative measures or precautions during construction to protect historical or cultural resources; threatened or endangered species; wetlands; streams; floodplains; waterways; or other natural areas, provide the page number where this information is found. Recommendations are issued by the IL Dept. of Natural Resources, Army Corps of Engineers, US Fish & Wildlife Service, or other state, federal or local Agencies.

Section V – Labor Agreements

YES or NO (Circle One)

Are contractors bidding this project required to be or become party to a Project Labor Agreement or Multi-Project Labor Agreement? If YES, provide a page number where the agreement is located or attach a copy of the document. Agreements may not significantly restrict competition.

Section VI – Certification of Plans and Specifications

I do hereby certify that the Bidding documents and Plans and Specifications for the project entitled:

2024 LEAD SERVICE REPLACEMENT

have been prepared in accordance with the requirements of Ill. Adm. Code 662, Procedures for Issuing Loans from the Public Water Supply Loan Program for obtaining loan funds.

Consulting Engineer: *JAMES AMELSO* Phone Number: *(847) 823-0500*

Signature  Date *1/24/2024*

Loan Applicant's Authorized Representative: _____

Signature _____ Date _____

DOCUMENTATION REQUIRED IN PLANS AND SPECIFICATIONS
FOR PROJECTS TO BE CONSTRUCTED UNDER THE
PUBLIC WATER SUPPLY LOAN PROGRAM

The attached “**front-end document package**” may be utilized by the loan applicant to comply with regulations for loans issued under the Public Water Supply Loan Program. The loan applicant’s use of the front-end document package and the completion and certification of the review checklist denoting the specific location of the required items as part of the submittal of the plans/specifications and permit application will help expedite the overall review of your project’s contract documents.

Rev. May 2003
Rev. April 2006
Rev. April 2007
Rev. April 2009
Rev. June 2010
Rev. February 2013
Rev. February 2014
Rev. December 2014
Rev. February 2016
Rev. May 2016
Rev. March 2017
Rev. December 2017
Rev. September 2018 (AIS)
Rev. November 2019
Rev. November 2020 (IL Workers Act)
Rev. March 17, 2021 (Apprenticeship)
Rev. April 22, 2022 (Removes IL Workers Act Alert)
Rev. July 2022 (BABA)
Rev. September 2022 (Apprenticeship Quarterly Report)
Rev. April 2023 (Revised Apprenticeship Quarterly Report)

IL532-2564
WPC 688

TABLE OF CONTENTS

<i>Page Number</i>	
6	Advertisement for Bids
7	Information for Bidders
9	Bid Form or Proposal with Davis-Bacon Wage Act Requirements
19	Bid Bond
21	Agreement
24	Performance Bond
26	Payment Bond
28	Notice of Intent to Award
29	Notice of Award
30	Notice to Proceed
31	Change Order
32	Affirmative Action for Equal Employment Opportunity (E.O. 11246)
44	U.S.EPA Certification of Nonsegregated Facilities
45	Nondiscrimination in Employment Form
46	Certification Regarding Debarment, Suspension, & Other Responsibility Matters
48	IEPA requirements for Construction Contracts of Loan Recipients and Other Applicable Sections from “Procedures for Issuing Loans from the Public Water Supply Loan Program”.
52	Bidder Certification Regarding Compliance with Article 33E “Criminal Code of 2012”
53-55	Disadvantaged Business Enterprise Participation Specifications (DBE)
56	Suggested DBE Advertisement for Construction Contractors
57	Summary of DBE Requirements for Bidders
59-60	DBE Forms for Bidders
61	Build America, Buy America Act Certification Form
62-64	Information Regarding the use of Iron, Steel, Manufactured Products, and Construction Materials produced in the United States
65-71	Illinois Works Jobs Program Act – Apprenticeship Initiative Information

ADVERTISEMENT FOR BIDS

Village of Forest Park
Owner
517 Des Plaines Ave
Address
Forest Park, IL 60130

Separate sealed BIDS for the construction of (briefly describe nature, scope, and major elements of the work):

Various Partial Lead Service Replacements within the Village of Forest Park as shown on the map included in theses bid docs.

will be received by: the Village of Forest Park

at Forest Park Village Hall (517 Des Plaines Ave, Forest Park, IL)

until: August 27th, (Standard Time-Daylight Savings Time) at 10:00 a.m., 2024, and then at said office publicly opened and read aloud.

“Any contract or contracts awarded under this invitation for bids are expected to be funded in part by a loan from the Illinois Environmental Protection Agency (Illinois EPA). Neither the State of Illinois nor any of its departments, agencies, or employees is or will be a party to this invitation for bids or any resulting contract. The procurement will be subject to regulations contained in the Procedures for Issuing Loans from the Public Water Supply Loan Program (35IAC Part 662), the Davis-Bacon Act (40 USC 276a through 276a-5) as defined by the United States Department of Labor, the Employment of Illinois Workers on Public Works Act (30 ILCS 570), Illinois Works Jobs Program Act (30 ILCS 559/20-1), and the federal AIS requirements contained in the Infrastructure Investment and Jobs Act, Pub. L. No. 117-58.

This procurement is also subject to the loan recipient’s policy regarding the increased use of disadvantaged business enterprises. The loan recipient’s policy requires all bidders to undertake specified affirmative efforts at least sixteen (16) days prior to bid opening. The policy is contained in the specifications. Bidders are also required to comply with the President’s Executive Order No. 11246, as amended. The requirements for bidders and contractors under this order are explained in 41 CFR 60-4.”

The CONTRACT DOCUMENTS may be examined at the following locations: Christopher B. Burke Engineering, Ltd. 9575 W. Higgins Road, Rosemont, IL Suite 600

Copies of the CONTRACT DOCUMENTS may be obtained via Quest CDN.com # located at: upon payment of \$50 for each set.

Any BIDDER, upon returning the CONTRACT DOCUMENTS promptly and in good condition, will be refunded his or her payment, and any non-bidder upon so returning the CONTRACT DOCUMENTS will be refunded the amount of \$ 0.

DATE SIGNATURE

INFORMATION FOR BIDDERS

BIDS will be received by the Village of Forest Park

(herein called the "OWNER"), online via QuestCDN.com _____

until Tuesday, August 27, 2024, at 10:00 a.m. and then at said office publicly opened and read aloud.

Each BID must be submitted in a sealed envelope, addressed to the Village of Forest Park at _____. Each sealed envelope containing a BID must be plainly marked on the outside as BID for Forest Park Lead Service Replacement Project – Phase 1 and the envelope should bear on the outside the name of the BIDDER, his/her address, his/her license number if applicable and the name of the project for which the BID is submitted. If forwarded by mail, the sealed envelope containing the BID must be enclosed in another envelope addressed to the OWNER at 517 Des Plaines Ave, Forest Park, IL 60130.

All BIDS must be made on the required BID form. All blank spaces for BID prices must be filled in, in ink or typewritten, and the BID form must be fully completed and executed when submitted. Only one copy of the BID form is required.

Any BID may be modified or withdrawn prior to the above scheduled time for the opening of BIDS or authorized postponement thereof. Any BID received after the time and date specified shall not be considered. No BIDDER may withdraw a BID within ____ days after the actual date of the opening thereof. Should there be reasons why the contract cannot be awarded within the specified period, the time may be extended by mutual agreement between the OWNER and the BIDDER.

BIDDERS must satisfy themselves of the accuracy of the estimated quantities in the BID Schedule by examination of the site and a review of the drawings and specifications including ADDENDA. After BIDS have been submitted, the BIDDER shall not assert that there was a misunderstanding concerning the quantities of WORK or of the nature of the WORK to be done.

The OWNER shall provide to BIDDERS prior to BIDDING, all information that is pertinent to, and delineates and describes, the land owned and rights-of-way acquired or to be acquired.

The CONTRACT DOCUMENTS contain the provisions required for the construction of the PROJECT. Information obtained from an officer, agent, or employee of the OWNER or any other person shall not affect the risks or obligations assumed by the CONTRACTOR or relieve him or her from fulfilling any of the conditions of the contract.

A BID bond payable to the OWNER must accompany each BID for five percent of the total amount of the BID. As soon as the BID prices have been compared, the OWNER will return the BONDS of all except the three lowest responsible BIDDERS. When the Agreement is executed the bonds of the two remaining unsuccessful BIDDERS will be returned. The BID BOND of the successful BIDDER will be retained until the payment BOND and performance BOND have been executed and approved, after which it will be returned. A certified check may be used in lieu of a BID BOND.

A performance BOND and a payment BOND, each in the amount of 100 percent of the CONTRACT PRICE, with a corporate surety approved by the OWNER, will be required for the faithful performance of the contract.

Attorneys-in-fact who sign BID BONDS or payment BONDS and performance BONDS must file with each BOND a certified and effective dated copy of their power of attorney.

Any contract entered into by the loan recipient and any sub-agreement hereunder, shall provide that representatives of the Agency will have access to the work whenever it is in preparation or progress and that the contractor or subcontractor will provide proper facilities for such access and inspection. Such contract or sub-agreement must also provide that the Agency or any authorized representative shall have

access to any books, documents, papers, and records of the contractor or subcontractor, which are pertinent to the project for the purpose of making audit, examination, excerpts, and transcriptions thereof.

The party to whom the contract is awarded will be required to execute the Agreement and obtain the performance BOND and payment BOND within ten (10) calendar days from the date when NOTICE OF AWARD is delivered to the BIDDER. The necessary Agreement and BOND forms shall accompany the NOTICE OF AWARD. In case of failure of the BIDDER to execute the Agreement, the OWNER may at his or her or her option consider the BIDDER in default, in which case the BID BOND accompanying the proposal shall become the property of the OWNER.

The OWNER within ten (10) days of receipt of acceptable performance BOND, payment BOND and Agreement signed by the party to whom the Agreement was awarded shall sign the Agreement and return to such party an executed duplicate of the Agreement. Should the OWNER not execute the Agreement within such period, the BIDDER may by WRITTEN NOTICE withdraw his or her signed Agreement. Such notice of withdrawal shall be effective upon receipt of the notice by the OWNER.

The OWNER shall issue the NOTICE TO PROCEED within ten (10) days of the execution of the Agreement. Should there be reasons why the NOTICE TO PROCEED cannot be issued within such period, the time may be extended by mutual agreement between the OWNER and CONTRACTOR. If the NOTICE TO PROCEED has not been issued within the ten (10) day period or within the period mutually agreed upon, the CONTRACTOR might terminate the Agreement without further liability on the part of either party.

The OWNER may make such investigations as he or she deems necessary to determine the ability of the BIDDER to perform the WORK, and the BIDDER shall furnish to the OWNER all such information and data for this purpose as the OWNER may request. The OWNER reserves the right to reject any BID if the evidence submitted by, or investigation of, such BIDDER fails to satisfy the OWNER that such BIDDER is properly qualified to carry out the obligations of the Agreement and to complete the WORK contemplated therein.

A conditional or qualified BID will not be accepted.

Award will be made to the low, responsive, responsible BIDDER.

All applicable laws, ordinances, and the rules and regulations of all authorities having jurisdiction over construction of the PROJECT shall apply to the contract throughout including the Employment of Illinois Workers on Public Works Act (30 ILCS 570) and the Davis-Bacon Wage Act (40 USC 276a through 276a-5) as defined by the United States Department of Labor.

This project will be exempt from the federal Build America, Buy America Act (BABA) which is included in the Infrastructure Investment and Jobs Act, Pub. L. No. 117-58 and specifies that all iron, steel, manufactured products, and construction materials used in the project are produced in the United States.

BIDDER shall not discriminate based on race, color, national origin, or sex in the performance of this contract. The contractor shall carry out applicable requirements of 40 CFR Part 33 in the award and administration of contracts awarded under EPA financial assistance agreements. Failure by the contractor to carry out these requirements is a material breach of this contract which may result in the termination of this contract or other legally available remedies.

Each BIDDER is responsible for inspecting the site and for reading and being thoroughly familiar with the CONTRACT DOCUMENTS. The failure or omission of any BIDDER to do any of the foregoing shall in no way relieve any BIDDER from any obligation in respect to his BID.

Each BIDDER shall supply a list of all subcontractors that submitted proposals and if requested by the OWNER all major material suppliers.

Inspection trips for prospective BIDDERS will leave from the office of the

_____ at _____

The ENGINEER is _____ His/her address is _____

BID FORM OR PROPOSAL

Proposal of _____ (hereinafter called "BIDDER"), organized and existing under the laws of the State of Illinois doing business as _____* to the _____(hereinafter called "OWNER").

In compliance with your Advertisement for Bids, BIDDER hereby proposes to perform all WORK for the construction of _____

in strict accordance with the CONTRACT DOCUMENTS, within the time set forth therein, and at the prices stated below.

BIDDER hereby agrees to commence WORK under this contract on or before a date to be specified in the NOTICE TO PROCEED and to fully complete the PROJECT within _____ consecutive calendar days thereafter. BIDDER further agrees to pay as liquidated damages, the sum of \$_____ for each consecutive calendar day thereafter.

BIDDER certifies that all iron, steel, manufactured products, and construction materials used in the project for the construction, alteration, maintenance, or repair of a public water system are produced in the United States in compliance with the federal Build America, Buy America Act, Pub. L. No. 117-58 §§ 70901-52.

* **Insert “a corporation”, “a partnership”, or “an individual” as applicable.**

(I) By submission of the bid, each bidder certifies, and in the case of a joint bid each party to the joint bid certifies, as to his or her own organization, that in connection with the bid:

- (i) The prices in the bid have been arrived at independently, without consultation, communication, or agreement with any other bidder or with any competitor, for the purpose of restricting competition, as to any matter relating to the prices;
- (ii) Unless otherwise required by law, the prices quoted in the bid have not knowingly been directly or indirectly disclosed to any other bidder or to any competitor prior to opening; and
- (iii) No attempt has been made or will be made by the bidder to induce any other person or firm to submit or withhold a bid for the purpose of restricting competition.

(II) Each person signing the bid shall certify that:

- (i) He or she is the person in the bidder’s organization responsible for the decision as to the prices being bid and that he or she has not participated, and will not participate, in any action contrary to (I)(i) through (I)(iii) above; or
- (ii) He or she is not the person in the bidder’s organization responsible for the decision as to the prices being bid, but that he or she has been authorized to act as agent certifying that the persons determining the prices have not participated, and will not participate, in any action contrary to (I)(i) through (I)(iii) above, and as their bidder’s agent shall so certify. He or she shall also certify that he or she has not participated, and will not participate, in any action contrary to (I)(i) through (I)(iii) above.

BIDDER acknowledges receipt of the following ADDENDUM (Where applicable): _____

BIDDER certifies that wages paid in connection with the PROJECT shall be paid at prevailing rates not less than those prevailing under the Davis-Bacon Wage Act. Bidder further certifies that the provisions contained in the following clauses will be exercised in the performance of any contract resulting from this BID and are made a part of the CONTRACT DOCUMENTS thereto by their inclusion in the BID as follows:

(1) *Minimum wages.*

- (i) All laborers and mechanics employed or working upon the site of the work, will be paid unconditionally and not less often than once a week, and without subsequent deduction or rebate on any account (except such payroll deductions as are permitted by regulations issued by the Secretary of Labor under the Copeland Act (29 CFR part 3)), the full amount of wages and bona fide fringe benefits (or cash equivalents thereof) due at time of payment computed at rates not less than those contained in the wage determination of the Secretary of Labor which is attached hereto and made a part hereof, regardless of any contractual relationship which may be alleged to exist between the contractor and such laborers and mechanics. Contributions made or costs reasonably anticipated for bona fide fringe benefits under section 1(b)(2) of the Davis Bacon Act on behalf of laborers or mechanics are considered wages paid to such laborers or mechanics, subject to the provisions of paragraph (a)(1)(iv) of this section; also, regular contributions made or costs incurred for more than a weekly period (but not less often than quarterly) under plans, funds, or programs which cover the particular weekly period, are deemed to be constructively made or incurred during such weekly period. Such laborers and mechanics shall be paid the appropriate wage rate and fringe benefits on the wage determination for the classification of work actually performed, without regard to skill, except as provided in §5.5(a)(4). Laborers or mechanics performing work in more than one classification may be compensated at the rate specified for each classification for the time actually worked therein: Provided, that the employer's payroll records accurately set forth the time spent in each classification in which work is performed. The wage determination (including any additional classification and wage rates conformed under paragraph (a)(1)(ii) of this section) and the Davis Bacon poster (WH-1321) shall be posted at all times by the contractor and its subcontractors at the site of the work in a prominent and accessible place where it can be easily seen by the workers. Sub recipients may obtain wage determinations from the U.S. Department of Labor's web site, <http://beta.sam.gov/>
- (ii) (A) The sub-recipient, on behalf of USEPA, shall require that any class of laborers or mechanics, including helpers, which is not listed in the wage determination and which is to be employed under the contract shall be classified in conformance with the wage determination. The USEPA award official shall approve an additional classification and wage rate and fringe benefits therefore only when the following criteria have been met:
 - (1) The work to be performed by the classification requested is not performed by a classification in the wage determination; and
 - (2) The classification is utilized in the area by the construction industry; and
 - (3) The proposed wage rate, including any bona fide fringe benefits, bears a reasonable relationship to the wage rates contained in the wage determination.
- (B) If the contractor and the laborers and mechanics to be employed in the classification (if known), or their representatives, and the sub-recipient agree on the classification and wage rate (including the amount designated for fringe benefits where appropriate), a report of the action taken shall be sent by the sub-recipient to IEPA. IEPA shall forward the report to the Administrator of the Wage and Hour Division, U.S. Department of Labor, Washington,

DC 20210. The Administrator, or an authorized representative, will approve, modify, or disapprove every additional classification action within 30 days of receipt and so advise IEPA or will notify IEPA within the 30-day period that additional time is necessary.

(C) In the event the contractor, the laborers, or mechanics to be employed in the classification or their representatives, and the sub-recipient do not agree on the proposed classification and wage rate (including the amount designated for fringe benefits, where appropriate), IEPA shall refer the questions, including the views of all interested parties and the recommendation of the sub-recipient, to the Administrator for determination. The Administrator, or an authorized representative, will issue a determination within 30 days of receipt and so advise IEPA or will notify IEPA within the 30-day period that additional time is necessary.

(D) The wage rate (including fringe benefits where appropriate) determined pursuant to paragraphs (a)(1)(ii)(B) or (C) of this section, shall be paid to all workers performing work in the classification under this contract from the first day on which work is performed in the classification.

- (iii) Whenever the minimum wage rate prescribed in the contract for a class of laborers or mechanics includes a fringe benefit which is not expressed as an hourly rate, the contractor shall either pay the benefit as stated in the wage determination or shall pay another bona fide fringe benefit or an hourly cash equivalent thereof.
- (iv) If the contractor does not make payments to a trustee or other third person, the contractor may consider as part of the wages of any laborer or mechanic the amount of any costs reasonably anticipated in providing bona fide fringe benefits under a plan or program, Provided, that the Secretary of Labor has found, upon the written request of the contractor, that the applicable standards of the Davis Bacon Act have been met. The Secretary of Labor may require the contractor to set aside, in a separate account, assets for the meeting of obligations under the plan or program.

(2) *Withholding.* The sub-recipient shall upon its own action or upon written request of an authorized representative of the Department of Labor withhold or cause to be withheld from the contractor under this contract or any other Federal contract with the same prime contractor, or any other federally-assisted contract subject to Davis Bacon prevailing wage requirements, which is held by the same prime contractor, so much of the accrued payments or advances as may be considered necessary to pay laborers and mechanics, including apprentices, trainees, and helpers, employed by the contractor or any subcontractor the full amount of wages required by the contract. In the event of failure to pay any laborer or mechanic, including any apprentice, trainee, or helper, employed or working on the site of the work, all or part of the wages required by the contract, the sub-recipient may, after written notice to the contractor, sponsor, applicant, or owner, take such action as may be necessary to cause the suspension of any further payment, advance, or guarantee of funds until such violations have ceased.

(3) *Payrolls and basic records.*

- (i) Payrolls and basic records relating thereto shall be maintained by the contractor during the course of the work and preserved for a period of three years thereafter for all laborers and mechanics working at the site of the work. Such records shall contain the name, address, and social security number of each such worker, his or her correct classification, hourly rates of wages paid (including rates of contributions or costs anticipated for bona fide fringe benefits or cash equivalents thereof of the types described in section 1(b)(2)(B) of the Davis Bacon Act), daily and weekly number of hours worked, deductions made and actual wages

- paid. Whenever the Secretary of Labor has found under 29 CFR 5.5(a)(1)(iv) that the wages of any laborer or mechanic include the amount of any costs reasonably anticipated in providing benefits under a plan or program described in section 1(b)(2)(B) of the Davis Bacon Act, the contractor shall maintain records which show that the commitment to provide such benefits is enforceable, that the plan or program is financially responsible, and that the plan or program has been communicated in writing to the laborers or mechanics affected, and records which show the costs anticipated or the actual cost incurred in providing such benefits. Contractors employing apprentices or trainees under approved programs shall maintain written evidence of the registration of apprenticeship programs and certification of trainee programs, the registration of the apprentices and trainees, and the ratios and wage rates prescribed in the applicable programs.
- (ii) (A) The contractor shall submit weekly for each week in which any contract work is performed a copy of all payrolls to the sub-recipient. Such documentation shall be available upon request of IEPA or USEPA. The payrolls submitted shall set out accurately and completely all of the information required to be maintained under 29 CFR 5.5(a)(3)(i), except that full social security numbers and home addresses shall not be included on weekly transmittals. Instead the payrolls shall only need to include an individually identifying number for each employee (e.g., the last four digits of the employee's social security number). The required weekly payroll information may be submitted in any form desired. Optional Form WH-347 is available for this purpose from the Wage and Hour Division Website, [<https://www.dol.gov/whd/forms/index.htm>]. The prime contractor is responsible for the submission of copies of payrolls by all subcontractors. Contractors and subcontractors shall maintain the full social security number and current address of each covered worker and shall provide them upon request to the sub-recipient, for transmission to the IEPA, USEPA, the contractor, or the Wage and Hour Division of the Department of Labor for purposes of an investigation or audit of compliance with prevailing wage requirements. It is not a violation of this section for a prime contractor to require a subcontractor to provide addresses and social security numbers to the prime contractor for its own records, without weekly submission to the sub-recipient.
- (B) Each payroll submitted shall be accompanied by a "Statement of Compliance," signed by the contractor or subcontractor or his or her agent who pays or supervises the payment of the persons employed under the contract and shall certify the following:
- (1) That the payroll for the payroll period contains the information required to be provided under §5.5 (a)(3)(ii) of Regulations, 29 CFR part 5, the appropriate information is being maintained under §5.5 (a)(3)(i) of Regulations, 29 CFR part 5, and that such information is correct and complete;
 - (2) That each laborer or mechanic (including each helper, apprentice, and trainee) employed on the contract during the payroll period has been paid the full weekly wages earned, without rebate, either directly or indirectly, and that no deductions have been made either directly or indirectly from the full wages earned, other than permissible deductions as set forth in Regulations, 29 CFR part 3;
 - (3) That each laborer or mechanic has been paid not less than the applicable wage rates and fringe benefits or cash equivalents for the classification of work performed, as specified in the applicable wage determination incorporated into the contract.
- (C) The weekly submission of a properly executed certification set forth on the reverse side of Optional Form WH-347 shall satisfy the requirement for submission of the "Statement of Compliance" required by paragraph (a)(3)(ii)(B) of this section.

- (D) The falsification of any of the above certifications may subject the contractor or subcontractor to civil or criminal prosecution under section 1001 of title 18 and section 231 of title 31 of the United States Code.
- (iii) The contractor or subcontractor shall make the records required under paragraph (a)(3)(i) of this section available for inspection, copying, or transcription by authorized representatives of IEPA, USEPA or the Department of Labor, and shall permit such representatives to interview employees during working hours on the job. If the contractor or subcontractor fails to submit the required records or to make them available, the Federal agency may, after written notice to the contractor, sponsor, applicant, or owner, take such action as may be necessary to cause the suspension of any further payment, advance, or guarantee of funds. Furthermore, failure to submit the required records upon request or to make such records available may be grounds for debarment action pursuant to 29 CFR 5.12.

(4) *Apprentices and trainees*

- (i) *Apprentices.* Apprentices will be permitted to work at less than the predetermined rate for the work they performed when they are employed pursuant to and individually registered in a bona fide apprenticeship program registered with the U.S. Department of Labor, Employment and Training Administration, Office of Apprenticeship Training, Employer and Labor Services, or with a State Apprenticeship Agency recognized by the Office, or if a person is employed in his or her first 90 days of probationary employment as an apprentice in such apprenticeship program, who is not individually registered in the program, but who has been certified by the Office of Apprenticeship Training, Employer and Labor Services, or a State Apprenticeship Agency (where appropriate) to be eligible for probationary employment as an apprentice. The allowable ratio of apprentices to journeymen on the job site in any craft classification shall not be greater than the ratio permitted to the contractor as to the entire work force under the registered program. Any worker listed on a payroll at an apprentice wage rate, who is not registered or otherwise employed as stated above, shall be paid not less than the applicable wage rate on the wage determination for the classification of work actually performed. In addition, any apprentice performing work on the job site in excess of the ratio permitted under the registered program shall be paid no less than the applicable wage rate on the wage determination for the work actually performed. Where a contractor is performing construction on a project in a locality other than that in which its program is registered, the ratios and wage rates (expressed in percentages of the journeyman's hourly rate) specified in the contractor's or subcontractor's registered program shall be observed. Every apprentice must be paid at not less than the rate specified in the registered program for the apprentice's level of progress, expressed as a percentage of the journeymen hourly rate specified in the applicable wage determination. Apprentices shall be paid fringe benefits in accordance with the provisions of the apprenticeship program. If the apprenticeship program does not specify fringe benefits, apprentices must be paid the full amount of fringe benefits listed on the wage determination for the applicable classification. If the Administrator determines that a different practice prevails for the applicable apprentice classification, fringes shall be paid in accordance with that determination. In the event the Office of Apprenticeship Training, Employer and Labor Services, or a State Apprenticeship Agency recognized by the Office, withdraws approval of an apprenticeship program, the contractor will no longer be permitted to utilize apprentices at less than the applicable predetermined rate for the work performed until an acceptable program is approved.

- (ii) *Trainees.* Except as provided in 29 CFR 5.16, trainees will not be permitted to work at less than the predetermined rate for the work performed unless they are employed pursuant to and individually registered in a program which has received prior approval, evidenced by form certification by the U.S. Department of Labor, Employment and Training Administration. The ratio of trainees to journeymen on the job site shall not be greater than permitted under the plan approved by the Employment and Training Administration. Every trainee must be paid at not less than the rate specified in the approved program for the trainee's level of progress, expressed as a percentage of the journeyman hourly rate specified in the applicable wage determination. Trainees shall be paid fringe benefits in accordance with the provisions of the trainee program. If the trainee program does not mention fringe benefits, trainees shall be paid the full amount of fringe benefits listed on the wage determination unless the Administrator of the Wage and Hour Division determines that there is an apprenticeship program associated with the corresponding journeyman wage rate on the wage determination which provides for less than full fringe benefits for apprentices. Any employee listed on the payroll at a trainee rate who is not registered and participating in a training plan approved by the Employment and Training Administration shall be paid not less than the applicable wage rate on the wage determination for the classification of work actually performed. In addition, any trainee performing work on the job site in excess of the ratio permitted under the registered program shall be paid not less than the applicable wage rate on the wage determination for the work actually performed. In the event the Employment and Training Administration withdraws approval of a training program, the contractor will no longer be permitted to utilize trainees at less than the applicable predetermined rate for the work performed until an acceptable program is approved.
- (iii) *Equal employment opportunity.* The utilization of apprentices, trainees and journeymen under this part shall be in conformity with the equal employment opportunity requirements of Executive Order 11246, as amended, and 29 CFR part 30.
- (5) *Compliance with Copeland Act requirements.* The contractor shall comply with the requirements of 29 CFR part 3, which are incorporated by reference in this contract.
- (6) *Subcontracts.* The contractor or subcontractor shall insert in any subcontracts the clauses contained in 29 CFR 5.5(a)(1) through (10) and such other clauses as the USEPA may by appropriate instruction require, and also a clause requiring the subcontractors to include these clauses in any lower tier subcontracts. The prime contractor shall be responsible for the compliance by any subcontractor or lower tier subcontractor with all the contract clauses in 29 CFR 5.5.
- (7) *Contract termination: debarment.* A breach of the contract clauses in 29 CFR 5.5 may be grounds for termination of the contract, and for debarment as a contractor and a subcontractor as provided in 29 CFR 5.12.
- (8) *Compliance with Davis Bacon and Related Act requirements.* All rulings and interpretations of the Davis Bacon and Related Acts contained in 29 CFR parts 1, 3, and 5 are herein incorporated by reference in this contract.
- (9) *Disputes concerning labor standards.* Disputes arising out of the labor standards provisions of this contract shall not be subject to the general disputes clause of this contract. Such disputes shall be resolved in accordance with the procedures of the Department of Labor set forth in 29 CFR parts 5, 6, and 7. Disputes within the meaning of this clause include disputes between the contractor (or any

of its subcontractors) and the contracting agency, the U.S. Department of Labor, or the employees or their representatives.

(10) Certification of eligibility.

- (i) By entering into this contract, the contractor certifies that neither it (nor he or she) nor any person or firm who has an interest in the contractor's firm is a person or firm ineligible to be awarded Government contracts by virtue of section 3(a) of the Davis Bacon Act or 29 CFR 5.12(a)(1).
- (ii) No part of this contract shall be subcontracted to any person or firm ineligible for award of a Government contract by virtue of section 3(a) of the Davis Bacon Act or 29 CFR 5.12(a)(1).
- (iii) The penalty for making false statements is prescribed in the U.S. Criminal Code, 18 U.S.C. 1001

Contract Provision for Contracts in Excess of \$100,000 - clauses (1) through (4) shall be inserted in full in any contract in excess of \$100,000 and subject to the overtime provisions of the Contract Work Hours and Safety Standards Act.

Contract Work Hours and Safety Standards Act

- (1) *Overtime requirements.* No contractor or subcontractor contracting for any part of the contract work which may require or involve the employment of laborers or mechanics shall require or permit any such laborer or mechanic in any workweek in which he or she is employed on such work to work in excess of forty hours in such workweek unless such laborer or mechanic receives compensation at a rate not less than one and one-half times the basic rate of pay for all hours worked in excess of forty hours in such workweek.
- (2) *Violation; liability for unpaid wages; liquidated damages.* In the event of any violation of the clause set forth in paragraph (b)(1) of this section the contractor and any subcontractor responsible therefor shall be liable for the unpaid wages. In addition, such contractor and subcontractor shall be liable to the United States (in the case of work done under contract for the District of Columbia or a territory, to such District or to such territory), for liquidated damages. Such liquidated damages shall be computed with respect to each individual laborer or mechanic, including watchmen and guards, employed in violation of the clause set forth in paragraph (b)(1) of this section, in the sum of \$25 for each calendar day on which such individual was required or permitted to work in excess of the standard workweek of forty hours without payment of the overtime wages required by the clause set forth in paragraph (b)(1) of this section.
- (3) *Withholding for unpaid wages and liquidated damages.* The sub-recipient, shall upon its own action or upon written request of the USEPA award official or an authorized representative of the Department of Labor, withhold or cause to be withheld, from any moneys payable on account of work performed by the contractor or subcontractor under any such contract or any other Federal contract with the same prime contractor, or any other federally-assisted contract subject to the Contract Work Hours and Safety Standards Act, which is held by the same prime contractor, such sums as may be determined to be necessary to satisfy any liabilities of such contractor or subcontractor for unpaid wages and liquidated damages as provided in the clause set forth in paragraph (b)(2) of this section.
- (4) *Subcontracts.* The contractor or subcontractor shall insert in any subcontracts the clauses set forth in paragraph (b)(1) through (4) of this section and also a clause requiring the

subcontractors to include these clauses in any lower tier subcontracts. The prime contractor shall be responsible for compliance by any subcontractor or lower tier subcontractor with the clauses set forth in paragraphs (b)(1) through (4) of this section.

The following shall be inserted into any contract subject only to the Contract Work Hours and Safety Standards Act.

The contractor or subcontractor shall maintain payrolls and basic payroll records during the course of the work and shall preserve them for a period of three years from the completion of the contract for all laborers and mechanics, including guards and watchmen, working on the contract. Such records shall contain the name and address of each such employee, social security number, correct classifications, hourly rates of wages paid, daily and weekly number of hours worked, deductions made, and actual wages paid. Further, the records to be maintained under this paragraph shall be made available by the contractor or subcontractor for inspection, copying, or transcription by authorized representatives of the USEPA and the Department of Labor, and the contractor or subcontractor will permit such representatives to interview employees during working hours on the job.

*******Insert applicable current Davis-Bacon Wage Rates Here*******

MAJOR ITEMS OF EQUIPMENT

It is hereby expressly agreed that the Contractor shall furnish and install in full compliance with the Plans and Contract Documents, the major items of equipment, as manufactured or supplied by the following listed manufacturers or suppliers:

No.	Description	Manufacturer or Supplier
1.		
2.		
3.		
4.		
5.		
6.		
7.		
8.		
9.		
10.		
11.		
12.		
13.		

BID BOND

KNOW ALL MEN AND WOMEN BY THESE PRESENTS, that we, the undersigned, _____
_____ as Principal, and
_____ as Surety, are hereby held and firmly
bound unto _____ as OWNER in the penal sum of
_____ for the payment of which, well and truly to be
made, we hereby jointly and severally bind ourselves, successors and assigns.

Signed, this _____ day of _____, 20 _____.

The Condition of the above obligation is such that whereas the Principal has submitted to
_____ a certain BID, attached hereto and
hereby made a part hereof to enter into a contract in writing, for the

NOW, THEREFORE,

- (a) If said BID shall be rejected, or
- (b) If said BID shall be accepted and the Principal shall execute and deliver a contract in the Form of Contract attached hereto (properly completed in accordance with said BID) and shall furnish a BOND for his faithful performance of said contract, and for the payment of all persons performing labor or furnishing materials in connection therewith, and shall in all other respects perform the agreement created by the acceptance of said BID, then this obligation shall be void, otherwise the same shall remain in force and effect; it being expressly understood and agreed that the liability of the Surety for any and all claims hereunder shall, in no event, exceed the penal amount of this obligation as herein stated.

The Surety, for value received, hereby stipulates and agrees that the obligations of said Surety and its BOND shall be in no way impaired or affected by any extension of the time within which the OWNER may accept such bid; and said Surety does hereby waive notice of any such extension.

IN WITNESS, WHEREOF, the Principal and the Surety have hereunto set their hands and seals, and such of them as are corporations have caused their corporate seals to be hereto affixed and these presents to be signed by their proper officers, the day and year first set forth above.

Principal (L.S.)

Surety

By: _____

IMPORTANT-Surety companies executing BONDS must appear on the Treasury Department's most current list (Circular 570 as amended) and be authorized to transact business in the state where the project is located.

AGREEMENT

THIS AGREEMENT, made this _____ day of _____, 20 _____, by and between _____, hereinafter called "OWNER" and _____ doing business as (an individual) or (a partnership) or (a corporation) hereinafter called "CONTRACTOR".

WITNESSETH: That for and in consideration of the payments and agreements hereinafter mentioned:

1. The CONTRACTOR will commence and complete the construction of _____

2. The CONTRACTOR will furnish all of the material, supplies, tools, equipment, labor and other services necessary for the construction and completion of the PROJECT described herein.

3. The CONTRACTOR will commence the work required by the Contract Documents within _____ calendar days after the date of the NOTICE TO PROCEED and will complete the same within _____ calendar days unless the period for completion is extended otherwise by the CONTRACT DOCUMENTS.

4. The CONTRACTOR agrees to perform all of the WORK described in the CONTRACT DOCUMENTS and comply with the terms therein for the sum of \$_____, or as shown in the BID schedule.

5. The term "CONTRACT DOCUMENTS" means and includes the following:
 - (A) Advertisement for BIDS
 - (B) Information for BIDDERS
 - (C) BID
 - (D) BID BOND
 - (E) Agreement
 - (F) Payment BOND
 - (G) Performance BOND
 - (H) NOTICE OF AWARD
 - (I) NOTICE TO PROCEED
 - (J) CHANGE ORDER
 - (K) DRAWINGS prepared by _____
numbered _____ through _____ and dated _____, 20 _____.

(L) SPECIFICATIONS prepared or issued by _____
_____,
dated _____, 20_____.

(M) ADDENDA:

No. _____, dated _____, 20_____

No. _____, dated _____, 20_____

No. _____, dated _____, 20_____

6. The OWNER will pay to the CONTRACTOR in the manner and at such times, such amounts as required by the CONTRACT DOCUMENTS.

7. The contractor shall not discriminate based on race, color, national origin or sex in the performance of this contract. The contractor shall carry out applicable requirements of 40 CFR Part 33 in the award and administration of contracts awarded under EPA financial assistance agreements. Failure by the contractor to carry out these requirements is a material breach of this contract which may result in the termination of this contract or other legally available remedies.

8. This Agreement shall be binding upon all parties hereto and their respective heirs, executors, administrators, successors, and assigns.

IN WITNESS WHEREOF, the parties hereto have executed, or caused to be executed by their duly authorized officials, this Agreement in (_____) each of which shall be deemed an original on the date first above written.

OWNER:

By _____
Name _____
Title _____

(Please Type)

(SEAL)

ATTEST:

Name _____
(Please Type)
Title _____

CONTRACTOR:

By _____
Name _____
Address _____

(Please Type)

(SEAL)

ATTEST:

Name _____
(Please Type)
Title _____

PERFORMANCE BOND

KNOW ALL MEN AND WOMEN BY THESE PRESENTS: that

(Name of Corporation)

(Address of Corporation)

a _____ hereinafter called Principal and
(Corporation, Partnership, or Individual)

(Name of Surety)

(Address of Surety)

hereinafter called Surety, are held and firmly bound unto _____

(Name of Owner)

(Address of Owner)

hereinafter called OWNER, in the penal sum of _____

_____ Dollars, \$(_____)

in lawful money of the United States, for the payment of which sum well and truly to be made, we bind ourselves, successors, and assigns, jointly and severally, firmly by these presents.

THE CONDITION OF THIS OBLIGATION is such that whereas, the Principal entered into a certain contract with the OWNER, dated the _____ day of _____ 20 _____, a copy of which is hereto attached and made a part hereof for the construction of:

NOW, THEREFORE, if the Principal shall well, truly and faithfully perform its duties, all the undertakings, covenants, terms, conditions, and agreements of said contract during the original term thereof, and any extensions thereof which may be granted by the OWNER, with or without notice to the Surety and during the one year guaranty period, and if he or she shall satisfy all claims and demands incurred under such contract, and shall fully indemnify and save harmless the OWNER from all costs and damages which it may suffer by reason of failure to do so, and shall reimburse and repay the OWNER all outlay and expense which the OWNER may incur in making good any default, then this obligation shall be void; otherwise to remain in full force and effect.

PROVIDED, FURTHER, that the said surety, for value received hereby stipulates and agrees that no change, extension of time, alteration or addition to the terms of the contract or to WORK to be performed hereunder or the SPECIFICATIONS accompanying the same shall in any wise affect its obligation on this BOND, and it does hereby waive notice of any such change, extension of time, alteration or addition to the terms of the contract or to the WORK or to the SPECIFICATIONS.

PROVIDED, FURTHER, that no final settlement between the OWNER and the CONTRACTOR shall abridge the right of any beneficiary hereunder, whose claim may be unsatisfied.

IN WITNESS WHEREOF, this instrument is executed in _____ counterparts, each one of which shall be deemed an original, this _____ day of _____ 20 _____.

ATTEST:

By: _____

(SEAL)

ATTEST:

(SEAL)

By: _____

NOTE: Date of BOND must not be prior to date of Contract.
If CONTRACTOR is Partnership, all partners should execute BOND.

IMPORTANT: Surety companies executing BONDS must appear on the Treasury Department's most current list (Circular 570 as amended) and be authorized to transact business in the state where the PROJECT is located.

PAYMENT BOND

KNOW ALL MEN AND WOMEN BY THESE PRESENTS: that

(Name of Contractor)

(Address of Contractor)

a _____, hereinafter called Principal, and
(Corporation, Partnership, or Individual)

(Name of Surety)

(Address of Surety)

hereinafter called SURETY, are held and firmly bound unto _____

(Name of Owner)

(Address of Owner)

hereinafter called OWNER, in the penal sum of _____ Dollars, (\$ _____)
in lawful money of the United States, for the payment of which sum well and truly to be made, we bind
ourselves, successors, and assigns, jointly and severally, firmly by these presents.

THE CONDITION OF THIS OBLIGATION is such that whereas, the Principal entered into a certain
contract with the OWNER, dated the _____ day of _____, 20____, a copy
of which is hereto attached and made a part hereof for the construction of :

_____.

NOW, THEREFORE, if the Principal shall promptly make payment to all persons, firms,
SUBCONTRACTORS, and corporations furnishing materials for or performing labor in the prosecution
of the WORK provided for in such contract, and any authorized extension or modification thereof,
including all amounts due for materials, lubricants, oil, gasoline, coal and coke, repairs on machinery,
equipment and tools, consumed or used in connection with the construction of such WORK, and all
insurance premiums on said WORK, and for all labor, performed in such WORK whether by
SUBCONTRACTOR or otherwise, then this obligation shall be void; otherwise to remain in full force
and effect.

PROVIDED, FURTHER, that the said Surety for value received hereby stipulates and agrees that no
change, extension of time, alteration, or addition to the terms of the contract or to the WORK to be
performed hereunder or the SPECIFICATIONS accompanying the same shall in any wise affect its

obligation on this BOND, and it does hereby waive notice of any such change, extension of time, alteration, or addition to the terms of the contract or to the WORK or to the SPECIFICATIONS.

PROVIDED, FURTHER, that no final settlement between the OWNER and the CONTRACTOR shall abridge the right of any beneficiary hereunder, whose claim may be unsatisfied.

IN WITNESS, WHEREOF, this instrument is executed in ____ counterparts, each one of which shall be deemed an original, this the _____ day of _____ 20 _____.

(SEAL)

ATTEST:

By: _____

ATTEST:

By: _____

NOTE: Date of BOND must not be prior to date of Contract.
If CONTRACTOR is Partnership, all partners should execute BOND.

IMPORTANT: Surety companies executing BONDS must appear on the Treasury Department's most current list (Circular 570 as amended) and be authorized to transact business in the state where the PROJECT is located.

NOTICE OF INTENT TO AWARD

To: _____

Project Description: _____

The OWNER has considered the BID submitted by you for the above described WORK, in response to its Advertisement for Bids, dated _____ and Information for Bidders.

You are hereby notified that your BID will be accepted, contingent upon Illinois Environmental Protection Agency (IEPA) approval, for items in the amount of _____.

You will be required by the Information for Bidders to execute the Agreement and furnish the required CONTRACTOR'S Performance BOND, Payment BOND and certificates of insurance within ten (10) calendar days from the date of the final Notice to be sent upon IEPA approval, to you.

Dated this day of _____

OWNER

By: _____

Title: _____

NOTICE OF AWARD

To: _____

PROJECT Description: _____

The OWNER has considered the BID submitted by you for the above-described WORK in response to its Advertisement for Bids dated _____, 20 _____ and Information for Bidders.

You are hereby notified that your BID has been accepted for items in the amount of \$_____.

You are required by the Information for Bidders to execute the Agreement and furnish the required CONTRACTOR'S Performance BOND, Payment BOND and certificates of insurance within ten (10) calendar days from the date of this Notice to you.

If you fail to execute said Agreement and to furnish said BONDS within ten (10) days from the date of this Notice, said OWNER will be entitled to consider all your rights arising out of the OWNER'S acceptance of your BID as abandoned and as a forfeiture of your BID BOND. The OWNER will be entitled to such other rights as may be granted by law.

You are required to return an acknowledged copy of this NOTICE OF AWARD to the OWNER.

Dated this _____ day of _____, 20 _____.

(Owner)

By _____

Title _____

ACCEPTANCE OF NOTICE

Receipt of the above NOTICE OF AWARD is hereby acknowledged,

by _____,

this the _____ day of _____, 20 _____.

By _____

Title _____

NOTICE TO PROCEED

To: _____

Date: _____
Project: _____

You are hereby notified to commence WORK in accordance with the Agreement dated _____, 20 _____, on or before _____, 20 _____, and you are to complete the WORK within _____ consecutive calendar days thereafter. The date of completion of all WORK is therefore _____, 20 _____.

(Owner)

By _____

Title _____

ACCEPTANCE OF NOTICE

Receipt of the above NOTICE TO PROCEED is hereby acknowledged by _____

this the _____ day of

_____, 20 _____.

By _____

Title _____

**NOTICE OF REQUIREMENT FOR AFFIRMATIVE ACTION TO ENSURE EQUAL
EMPLOYMENT OPPORTUNITY
(EXECUTIVE ORDER 11246)**

1. The Offeror's or Bidder's attention is called to the "Equal Opportunity Clause" and the "Standard Federal Equal Employment Opportunity Construction Contract Specifications" set forth herein.
2. The goals and timetables for minority and female participation, expressed in percentage terms for the Contractor's aggregate workforce in each trade on all construction work in the covered area, are as follows:

Timetables	Goals for minority participation for each trade	Goals for female participation in each trade
	Insert goals for* each year _____	Insert goals for* each year _____

These goals are applicable to all the Contractor's construction work (whether or not it is Federal or federally assisted) performed in the covered area.

The Contractor's compliance with the Executive Order and the regulations in 41 CFR Part 60-4 shall be based on its implementation of the Equal Opportunity Clause, specific affirmative action obligations required by the specifications set forth in 41 CFR 60-4.3(a), and its efforts to meet the goals established for the geographical area where the contract resulting from this solicitation is to be performed. The hours of minority and female employment and training must be substantially uniform throughout the length of the contract, and in each trade, and the contractor shall make a good faith effort to employ minorities and women evenly on each of its projects. The transfer of minority or female employees or trainees from Contractor to Contractor or from project to project for the sole purpose of meeting the Contractor's goals shall be a violation of the contract, the Executive Order and the regulations in 41 CFR 60-4. Compliance with the goals will be measured against the total work hours performed.

3. The Contractor shall provide written notification to the Director of the Office of Federal Contract Compliance Programs within 10 working days of award of any construction subcontract in excess of \$10,000 at any tier for construction work under the contract resulting from this solicitation. The notification shall list the name, address and telephone number of the subcontractor; employer identification number; estimated dollar amount of the subcontract; estimated starting and completion dates of the subcontract; and the geographical area in which the contract is to be performed.
4. As used in this Notice, and in the contract resulting from this solicitation, the "covered area" is **.

*goals and timetables published from time to time by the Director, Office of Federal Contract Compliance Programs (OFCCP)

**Insert description of the geographical areas where the contract is to be performed giving the state, county and city, if any.

**CONSTRUCTION CONTRACTORS AFFIRMATIVE ACTION REQUIREMENTS
GOALS FOR MINORITY PARTICIPATION**

(As published in the Friday, October 3, 1980 Federal Register)

FEMALE PARTICIPATION= 6.9% STATEWIDE

<u>County</u>	<u>Percent</u>	<u>County</u>	<u>Percent</u>	<u>County</u>	<u>Percent</u>
Adams	3.1	Jasper	11.4	Randolph	11.4
Alexander	11.4	Jefferson	11.4	Richland	11.4
Bond	11.4	Jersey	11.4	Rock Island	4.6
Boone	6.3	Jo Davis	0.5	Saline	3.5
Brown	3.1	Johnson	11.4	Sangamon	4.5
Bureau	18.4	Kane	19.6	Schuyler	3.3
Calhoun	11.4	Kankakee	9.1	Scott	4
Carroll	3.4	Kendall	18.4	Shelby	4
Cass	4	Knox	3.3	Stark	3.3
Champaign	7.8	Lake	19.6	St. Clair	14.7
Christian	4	La Salle	18.4	Stephenson	4.6
Clark	2.5	Lawrence	3.5	Tazwell	4.4
Clay	11.4	Lee	4.6	Union	11.4
Clinton	14.7	Livingston	18.4	Vermilion	4.8
Coles	4.8	Logan	4	Wabash	3.5
Cook	19.6	Macon	7.6	Warren	3.3
Crawford	2.5	Macoupin	11.4	Washington	11.4
Cumberland	4.8	Madison	14.7	Wayne	11.4
De Kalb	18.4	Marion	11.4	White	3.5
De Witt	4	Marshall	3.3	Whiteside	3.4
Douglas	4.8	Mason	3.3	Will	20.9
Du Page	19.6	Massac	5.2	Williamson	11.4
Edgar	4.8	McDonough	3.3	Winnebago	6.3
Edwards	3.5	McHenry	19.6	Woodford	4.4
Effingham	11.4	McLean	2.5		
Fayette	11.4	Menard	4.5		
Ford	4.8	Mercer	3.4		
Franklin	11.4	Monroe	14.7		
Fulton	3.3	Montgomery	11.4		
Gallatin	3.5	Morgan	4		
Greene	11.4	Moultrie	4		
Grundy	18.4	Ogle	4.6		
Hamilton	3.5	Peoria	4.4		
Hancock	3.4	Perry	11.4		
Hardin	5.2	Piatt	4.8		
Henderson	3.4	Pike	3.1		
Henry	4.6	Pope	5.2		
Iroquois	18.4	Pulaski	11.4		
Jackson	11.4	Putnam	18.4		

41 CFR 60**60-4.1 Scope and Application.**

This part applies to all contractors and subcontractors that hold any Federal or federally assisted construction contract in excess of \$10,000. The regulations in this part are applicable to all of a construction contractor's or subcontractor's construction employees who are engaged in on site construction including those construction employees who work on a non-Federal or non-federally assisted construction site. This part also establishes procedures, which all Federal contracting officers and all applicants, as applicable, shall follow in soliciting for and awarding Federal or federally assisted construction contracts. Procedures also are established which administering agencies shall follow in making any grant, contract, loan, insurance, or guarantee involving federally assisted construction which is not exempt from the requirements of Executive Order 11246, as amended. In addition, this part applies to construction work performed by construction contractors and subcontractors for Federal non-construction contractors and subcontractors if the construction work is necessary in whole or in part to the performance of a non-construction contract or subcontract.

[43 FR 49254, OCT. 20, 1978; 43 FR 51404, NOV. 3, 1978]

60-4.2 Solicitations.

(a) All Federal contracting officers and all applicants shall include the notice set forth in paragraph (d) of this section and the Standard Federal Equal Employment Opportunity Construction Contract Specifications set forth in § 60-4.3 of this part in all solicitations for offers and bids on all Federal and federally assisted construction contracts or subcontracts to be performed in geographical areas designated by the Director pursuant to § 60-4.6 of the part. Administering agencies shall require the inclusion of the notice set forth in paragraph (d) of this section and the specifications set forth in § 60-4.3 of this part as a condition of any grant, contract, subcontract, loan, insurance or guarantee involving federally assisted construction covered by this Part 60-4.

(b) All non-construction contractors covered by Executive Order 11246 and the implementing regulations shall include the notice in paragraph (d) of this section in all construction agreements, which are necessary in whole or in part to the performance of the covered non-construction contract.

(c) Contracting officers, applicants and non-construction contractors shall give written notice to the Director within 10 working days of award of a contract subject to these provisions. The notification shall include the name, address, and telephone number of the contractor; employer identification number; dollar amount of the contract, estimated starting and completion dates of the contract; the contract number; and geographical area in which the contract is to be performed.

(d) The following notice shall be included in, and shall be a part of, all solicitations for offers and bids on all Federal and federally assisted construction contracts or subcontracts in excess of \$10,000 to be performed in geographical areas designated by the Director pursuant to § 60-4.6 of this part (see 41 CFR 60-4.2(a)):

Notice of Requirement for Affirmative Action to Ensure Equal Employment Opportunity (Executive Order 11246)

1. The Offeror or Bidder's attention is called to the "Equal Opportunity Clause" and the "Standard Federal Equal Employment Specifications" set forth herein.
2. The goals and timetables for minority and female participation, expressed in percentage terms for the Contractor's aggregate workforce in each trade on all construction work in the covered area, are as follows:

Time- tables	Goals for minority participation for each trade	Goals for female participation in each trade
	Insert goals for each year.	Insert goals for each year.

These goals are applicable to all the Contractor's construction work (whether or not it is Federal or federally assisted) performed in the covered area. If the contractor performs construction work in a geographical area located outside of the covered area, it shall apply the goals established for such geographical area where the work is actually performed. With regard to this second area, the contractor also is subject to the goals for both its federally involved and non-federally involved construction.

The Contractor's compliance with the Executive Order and the regulations in 41 CFR Part 60-4 shall be based on its implementation of the Equal Opportunity Clause, specific affirmative action obligations required by the specifications set forth in 41 CFR 60-4.3(a), and its efforts to meet the goals. The hours of minority and female employment and training must be substantially uniform throughout the length of the contract, and in each trade, and the contractor shall make a good faith effort to employ minorities and women evenly on each of its projects. The transfer of minority or female employees or trainees from Contractor to Contractor or from project to project for the sole purpose of meeting the Contractor's goals shall be a violation of the contract, the Executive Order and the regulations in 41 CFR Part 60-4. Compliance with the goals will be measured against the total work hours performed.

3. The Contractor shall provide written notification to the Director of the Office of Federal Contract Compliance Programs within 10 working days of award of any construction subcontract in excess of \$10,000 at any tier for construction work under the contract resulting from this solicitation. The notification shall list the name, address and telephone number of the subcontractor; employer identification number of the subcontractor; estimated dollar amount of the subcontract; estimated starting and completion dates of the subcontract; and the geographical area in which the subcontract is to be performed.

4. As used in this Notice, and in the contract resulting from this solicitation, the "covered area" is (insert description of the geographical areas where the contract is to be performed giving the state, county, and city, if any).

[43 FR 49254, OCT. 20, 1978; 43 FR 51401, NOV. 3, 1978, AS AMENDED AT 45 FR 65977, OCT. 3, 1980]

60-4.3 Equal Opportunity Clauses.

(a) The equal opportunity clause published at 41 CFR 60-1.4(a) of this chapter is required to be included in, and is part of, all nonexempt Federal contracts and subcontracts, including construction contracts and subcontracts. The equal opportunity clause published at 41 CFR 60-1.4(b) is required to be included in, and is a part of, all nonexempt federally assisted construction contracts and subcontracts. In addition to the clauses described above, all Federal contracting officers, all applicants and all non-construction contractors, as applicable, shall include the specifications set forth in this section in all Federal and federally assisted construction contracts in excess of \$10,000 to be performed in geographical areas designated by the Director pursuant to § 60-4.6 of this part and in construction subcontracts in excess of \$10,000 necessary in whole or in part to the performance of non-construction Federal contracts and subcontracts covered under the Executive order.

Standard Federal Equal Employment Opportunity Construction Contract Specifications (Executive Order 11246)

1. As used in these specifications:

a. "Covered area," means the geographical area described in the solicitation from which this contract resulted:

b. "Director" means Director, Office of Federal Contract Compliance Programs, United States Department of Labor, or any person to whom the Director delegates authority;

c. "Employer identification number" means the Federal Social Security number used on the Employer's Quarterly Federal Tax Return, U.S. Treasury Department Form 941.

d. "Minority" includes:

(i) Black (all persons having origins in any of the Black African racial groups not of Hispanic origin);

(ii) Hispanic (all persons of Mexican, Puerto Rican, Cuban, Central or South American or other Spanish Culture or origin, regardless of race);

(iii) Asian and Pacific Islander (all persons having origins in any of the original peoples of the Far East, Southeast Asia, the Indian Subcontinent, or the Pacific Islands); and

(iv) American Indian or Alaskan Native (all persons having origins in any of the original peoples of North America and maintaining identifiable tribal affiliations through membership and participation or community identification).

2. Whenever the Contractor, or any Subcontractor at any tier, subcontracts a portion of the work involving any construction trade, it shall physically include in each subcontract in excess of \$10,000 the provisions of these specifications and the Notice which contains the applicable goals for minority and female participation and which is set forth in the solicitations from which this contract resulted.

3. If the Contractor is participating (pursuant to 41 CFR 60-4.5) in a Hometown Plan approved by the U.S. Department of Labor in the covered area either individually or through an association, its affirmative action obligations on all work in the Plan area (including goals and timetables) shall be in accordance with that Plan for those trades which have unions participating in the Plan. Contractors must be able to demonstrate their participation in and compliance with the provisions of any such Hometown Plan. Each Contractor or Subcontractor participating in an approved Plan is individually required to comply with its obligations under the EEO clause, and to make a good faith effort to achieve each goal under the Plan in each trade in which it has employees. The overall good faith performance by other Contractors or Subcontractors toward a goal in an approved Plan does not excuse any covered Contractor or Subcontractor's failure to take good faith efforts to achieve the Plan goals and timetables.

4. The Contractor shall implement the specific affirmative action standards provided in paragraphs 7 a through p of these specifications. The goals set forth in the solicitation from which this contract resulted are expressed as percentages of the total hours of employment and training of minority and female utilization the Contractor should reasonably be able to achieve in each construction trade in which it has employees in the covered area. Covered Construction contractors performing construction work in geographical areas where they do not have a Federal or federally assisted construction contract shall apply the minority and female goals established for the geographical area where the work is being performed. Goals are published periodically in the Federal Register in notice form, and such notices may be obtained from any Office of Federal Contract Compliance Programs office or from Federal procurement contracting officers. The Contractor is expected to make substantially uniform progress in meeting its goals in each craft during the period specified.

5. Neither the provisions of any collective bargaining agreement, nor the failure by a union with whom the Contractor has a collective bargaining agreement, to refer either minorities or women shall excuse the Contractor's obligations under these specifications, Executive Order 11246, nor the regulations promulgated pursuant thereto.

6. In order for the nonworking training hours of apprentices and trainees to be counted in meeting the goals, the Contractor must employ such apprentices and trainees during the training period, and the Contractor must have made a commitment to employ the apprentices and trainees at the completion of their training, subject to the availability of employment opportunities. Trainees must be trained pursuant to training programs approved by the U.S. Department of Labor.

7. The Contractor shall take specific affirmative action to ensure equal employment opportunity. The evaluation of the Contractor's compliance with these specifications shall be based upon its effort to achieve maximum results from its actions. The Contractor shall document these efforts fully, and shall implement affirmative action steps at least as extensive as the following:

a. Ensure and maintain a working environment free of harassment, intimidation, and coercion at all sites, and in all facilities at which the Contractor's employees are assigned to work. The Contractor, where possible, will assign two or more women to each construction project. The Contractor shall specifically ensure that all foremen, superintendents, and other on-site supervisory personnel are aware of and carry out the Contractor's obligation to maintain such a working environment, with specific attention to minority or female individuals working at such sites or in such facilities.

b. Establish and maintain a current list of minority and female recruitment sources, provide written notification to minority and female recruitment sources and to community organizations when the Contractor or its unions have employment opportunities available, and maintain a record of the organizations' responses.

c. Maintain a current file of the names, addresses and telephone numbers of each minority and female off-the-street applicant and minority or female referral from a union, a recruitment source or community organization and of what action was taken with respect to each such individual. If such individual was sent to the union hiring hall for referral and was not referred back to the Contractor by the union or, if referred, not employed by the Contractor, this shall be documented in the file with the reason; therefore, along with whatever additional actions the Contractor may have taken.

d. Provide immediate written notification to the Director when the union or unions with which the Contractor has a collective bargaining agreement has not referred to the Contractor a minority person or woman sent by the Contractor, or when the Contractor has other information that the union referral process has impeded the Contractor's efforts to meet its obligations.

e. Develop on-the-job training opportunities and/or participate in training programs for the area which expressly include minorities and women, including upgrading programs and apprenticeship and trainee programs relevant to the Contractor's employment needs, especially those programs funded or approved by the Department of Labor. The Contractor shall provide notice of these programs to the sources compiled under 7b above.

f. Disseminate the Contractor's EEO policy by providing notice of the policy to unions and training programs and requesting their cooperation in assisting the Contractor in meeting its EEO obligations; by including it in any policy manual and collective bargaining agreement; by publicizing it in the company newspaper, annual report, etc.; by specific review of the policy with all management personnel and with all minority and female employees at least once a year; and by posting the company EEO policy on bulletin boards accessible to all employees at each location where construction work is performed.

g. Review, at least annually, the company's EEO policy and affirmative action obligations under these specifications with all employees having any responsibility for hiring, assignment, layoff, termination, or other employment decisions including specific review of these items with onsite supervisory personnel such as Superintendents, General Foremen, etc., prior to the initiation of construction work at any job site. A written record shall be made and maintained identifying the time and place of these meetings, persons attending, subject matter discussed, and disposition of the subject matter.

h. Disseminate the Contractor's EEO policy externally by including it in any advertising in the news media, specifically including minority and female news media, and providing written notification to and discussing the Contractor's EEO policy with other Contractors and Subcontractors with whom the Contractor does or anticipates doing business.

i. Direct its recruitment efforts, both oral and written, to minority, female and community organizations, to schools with minority and female students and to minority and female recruitment and training organizations serving the Contractor's recruitment area and employment needs. Not later than one month prior to the date for the acceptance of applications for apprenticeship or other training by any recruitment source, the Contractor shall send written notification to organizations such as the above, describing the openings, screening procedures, and tests to be used in the selection process.

j. Encourage present minority and female employees to recruit other minority persons and women and, where reasonable, provide after school, summer and vacation employment to minority and female youth both on the site and in other areas of a contractor's work force.

k. Validate all tests and other selection requirements where there is an obligation to do so under 41 CFR Part 60-3.

l. Conduct, at least annually, an inventory and evaluation at least of all minority and female personnel for promotional opportunities and encourage these employees to seek or to prepare for, through appropriate training, etc., such opportunities.

m. Ensure that seniority practices, job classifications, work assignments and other personnel practices, do not have a discriminatory effect by continually monitoring all personnel and employment related activities to ensure that the EEO policy and the Contractor's obligations under these specifications are being carried out.

n. Ensure that all facilities and company activities are non-segregated except that separate or single-user toilet and necessary changing facilities shall be provided to assure privacy between the sexes.

o. Document and maintain a record of all solicitations of offers for subcontracts from minority and female construction contractors and suppliers, including circulation of solicitations to minority and female contractor associations and other business associations.

p. Conduct a review, at least annually, of all supervisors' adherence to and performance under the Contractor's EEO policies and affirmative action obligations.

8. Contractors are encouraged to participate in voluntary associations, which assist in fulfilling one or more of their affirmative action obligations (7a through p). The efforts of a contractor association, joint contractor-union, contractor-community, or other similar group of which the contractor is a member and participant, may be asserted as fulfilling any one or more of its obligations under 7a through p of these Specifications provided that the contractor actively participates in the group, makes every effort to assure that the group has a positive impact on the employment of minorities and women in the industry, ensures that the concrete benefits of the

program are reflected in the Contractor's minority and female workforce participation, makes a good faith effort to meet its individual goals and timetables, and can provide access to documentation which demonstrates the effectiveness of actions taken on behalf of the Contractor. The obligation to comply, however, is the Contractor's and failure of such a group to fulfill an obligation shall not be a defense for the Contractor's noncompliance.

9. A single goal for minorities and a separate single goal for women have been established. The Contractor, however, is required to provide equal employment opportunity and to take affirmative action for all minority groups, both male and female, and all women, both minority and non-minority. Consequently, the Contractor may be in violation of the Executive Order if a particular group is employed in a substantially disparate manner (for example, even though the Contractor has achieved its goals for women generally, the Contractor may be in violation of the Executive Order if a specific minority group of women is underutilized).

10. The Contractor shall not use the goals and timetables or affirmative action standards to discriminate against any person because of race, color, religion, sex, or national origin.

11. The Contractor shall not enter into any Subcontract with any person or firm debarred from Government contracts pursuant to Executive Order 11246.

12. The Contractor shall carry out such sanctions and penalties for violation of these specifications and of the Equal Opportunity Clause, including suspension, termination and cancellation of existing subcontracts as may be imposed or ordered pursuant to Executive Order 11246, as amended, and its implementing regulations, by the Office of Federal Contract Compliance Programs. Any Contractor who fails to carry out such sanctions and penalties shall be in violation of these specifications and Executive Order 11246, as amended.

13. The Contractor, in fulfilling its obligations under these specifications, shall implement specific affirmative action steps, at least as extensive as those standards prescribed in paragraph 7 of these specifications, so as to achieve maximum results from its efforts to ensure equal employment opportunity. If the Contractor fails to comply with the requirements of the Executive Order, the implementing regulations, or these specifications, the Director shall proceed in accordance with 41 CFR 60-4.8.

14. The Contractor shall designate a responsible official to monitor all employment related activity to ensure that the company EEO policy is being carried out, to submit reports relating to the provisions hereof as may be required by the Government and to keep records. Records shall at least include for each employee the name, address, telephone numbers, construction trade, union affiliation if any, employee identification number when assigned, social security number, race, sex, status (e.g., mechanic, apprentice trainee, helper, or laborer), dates of changes in status, hours worked per week in the indicated trade, rate of pay, and locations at which the work was performed. Records shall be maintained in an easily understandable and retrievable form; however, to the degree that existing records satisfy this requirement, contractors shall not be required to maintain separate records.

15. Nothing herein provided shall be construed as a limitation upon the application of other laws, which establish different standards of compliance or upon the application of requirements for the

hiring of local or other area residents (e.g., those under the Public Works Employment Act of 1977 and the Community Development Block Grant Program).

(b) The notice set forth in 41 CFR 60-4.2 and the specifications set forth in 41 CFR 60-4.3 replace the New Form for Federal Equal Employment Opportunity Bid Conditions for Federal and Federally Assisted Construction published at 41 FR 32482 and commonly known as the Model Federal EEO Bid Conditions, and the New Form shall not be used after the regulations in 41 CFR Part 60-4 become effective.

[43 FR 49254, OCT. 20, 1978; 43 FR 51401, NOV. 3, 1978, AS AMENDED AT 45 FR 65978, OCT. 3, 1980]

60-4.4 Affirmative Action Requirements.

(a) To implement the affirmative action requirements of Executive Order 11246 in the construction industry, the Office of Federal Contract Compliance Programs previously has approved affirmative action programs commonly referred to as "Hometown Plans," has promulgated affirmative action plans referred to as "Imposed Plans" and has approved "Special Bid Conditions" for high impact projects constructed in areas not covered by a Hometown or an Imposed Plan. All solicitations for construction contracts made after the effective date of the regulations in this part shall include the notice specified in § 60-4.2 of this part and the specifications in § 60-4.3 of this part in lieu of the Hometown and Imposed Plans including the Philadelphia Plan and Special Bid Conditions. Until the Director has issued an order pursuant to § 60-4.6 of this part establishing goals and timetables for minorities in the appropriate geographical areas or for a project covered by Special Bid Conditions, the goals and timetables for minorities to be inserted in the Notice required by 41 CFR 60-4.2 shall be the goals and timetables contained in the Hometown Plan, Imposed Plan or Special Bid Conditions presently covering the respective geographical area or project involved.

(b) Signatories to a Hometown Plan (including heavy highway affirmative action plans) shall have 45 days from the effective date of the regulations in this part to submit under such a Plan (for the director's approval) goals and timetables for women and to include female representation on the Hometown Plan Administrative Committee. Such goals for female representation shall be at least as high as the goals established for female representation in the notice issued pursuant to 41 CFR 60-4.6. Failure of the signatories, within the 45-day period, to include female representation and to submit goals for women or a new plan, as appropriate, shall result in an automatic termination of the Office of Federal Contract Compliance Program's approval of the Hometown Plan. At any time, the Office of Federal Contract Compliance Programs terminates or withdraws its approval of a Hometown Plan, or when the plan expires and another plan is not approved, the contractor signatory to the plan shall be covered automatically by the specifications set forth in § 60-4.3 of this part and by the goals and timetables established for that geographical area pursuant to § 60-4.6 of this part.

60-4.5 Hometown Plans

(a) A contractor participating, either individually or through an association, in an approved Hometown Plan (including heavy highway affirmative action plans) shall comply with its

affirmative action obligations under Executive Order 11246 by complying with its obligations under the plan: *Provided*, That each contractor or subcontractor participating in an approved plan is individually required to comply with the equal opportunity clause set forth in 41 CFR 60-1.4; to make a good faith effort to achieve the goals for each trade participating in the plan in which it has employees; and that the overall good performance by other contractors or subcontractors toward a goal in an approved plan does not excuse any covered contractor's or subcontractor's failure to take good faith efforts to achieve the plan's goals and timetables. If a contractor is not participating in an approved Hometown Plan it shall comply with the specifications set forth in § 60-4.3 of this part and with the goals and timetables for the appropriate area as listed in the notice required by 41 CFR 60-4.2 with regard to that trade. For the purposes of this part 60-4, a contractor is not participating in a Hometown Plan for a particular trade if it:

- (1) Ceases to be signatory to a Hometown Plan covering that trade;
 - (2) Is signatory to a Hometown Plan for that trade but is not party to a collective bargaining agreement for that trade;
 - (3) Is signatory to a Hometown Plan for that trade but is party to a collective bargaining agreement with labor organizations, which are not or cease to be signatories to the same Hometown Plan for that trade;
 - (4) Is signatory to a Hometown Plan for that trade but is party to a collective bargaining agreement with a labor organization for that trade but the two have not jointly executed a specific commitment to minority and female goals and timetables and incorporated the commitment in the Hometown Plan for that trade;
 - (5) Is participating in a Hometown Plan for that trade which is no longer acceptable to the Office of Federal Contract Compliance Programs;
 - (6) Is signatory to a Hometown Plan for that trade but is party to a collective bargaining agreement with a labor organization for that trade and the labor organization and the contractor have failed to make a good faith effort to comply with their obligations under the Hometown Plan for that trade.
- (b) Contractors participating in Hometown Plans must be able to demonstrate their participation and document their compliance with the provision of the Hometown Plan.

[43 FR 49254, OCT. 20, 1978; 43 FR 51401, NOV. 3, 1978]

60-4.6 Goals and Timetables.

The Director, from time to time, shall issue goals and timetables for minority and female utilization, which shall be based on appropriate workforce, demographic, or other relevant data and which shall cover construction projects or construction contracts performed in specific geographical areas. The goals, which shall be applicable to each construction trade in a covered contractor's or subcontractor's entire workforce which is working in the area covered by the goals and timetables, shall be published as notices in the Federal Register, and shall be inserted by the

contracting officers and applicants, as applicable, in the Notice required by 41 CFR 60-4.2. Covered construction contractors performing construction work in geographical areas where they do not have a Federal or federally assisted construction contract shall apply the minority and female goals established for the geographical area where the work is being performed.

[45 FR 65978, OCT. 3, 1980]

60-4.7 Effect on Other Regulations.

The regulations in this part are in addition to the regulations contained in this chapter, which apply to construction contractors and subcontractors generally. See particularly, 41 CFR 60-1.4 (a), (b), (c), (d), and (e); 60-1.5; 60-1.7; 60-1.8; 60-1.26; 60-1.29; 60-1.30; 60-1.32; 60-1.41; 60-1.42; 60-1.43; and 41 CFR Part 60-3; Part 60-20; Part 60-30; Part 60-40; and Part 60-50.

60-4.8 Show Cause Notice.

If an investigation or compliance review reveals that a construction contractor or subcontractor has violated the Executive order, any contract clause, specifications or the regulations in this chapter and if administrative enforcement is contemplated, the Director shall issue to the contractor or subcontractor a notice to show cause which shall contain the items specified in paragraphs (i) through (iv) of 41 CFR 60-2.2(c)(1). If the contractor does not show good cause within 30 days, or in the alternative, fails to enter an acceptable conciliation agreement which includes where appropriate, make up goals and timetables, back pay, and seniority relief for affected class members, the OFCCP shall follow the procedure in 41 CFR 60-1.26(b): *Provided*, That where a conciliation agreement has been violated, no show cause notice is required prior to the initiation of enforcement proceedings.

[43 FR 49254, OCT. 20, 1978; 43 FR 51401, NOV. 3, 1978]

60-4.9 Incorporation by Operation of the Order.

By operation of the order, the equal opportunity clause contained in § 60-1.4, the Notice of Requirement for Affirmative Action to Ensure Equal Employment Opportunity (Executive Order 11246) contained in § 60-4.2, and the Standard Federal Equal Employment Opportunity Construction Contract Specifications (Executive Order 11246) contained in § 60-4.3 shall be deemed to be a part of every solicitation or of every contract and subcontract, as appropriate, required by the order and the regulations in this chapter to include such clauses whether or not they are physically incorporated in such solicitation or contract and whether or not the contract is written.

U.S. ENVIRONMENTAL PROTECTION AGENCY
CERTIFICATION OF NONSEGREGATED FACILITIES

(Applicable to federally assisted construction contracts and related subcontracts exceeding \$10,000 that are not exempt from the Equal Opportunity clause.)

The federally assisted construction contractor certifies that he does not maintain or provide for his employees any segregated facilities at any of his establishments, and that he does not permit his employees to perform their services at any location, under his control, where segregated facilities are maintained. The federally assisted construction contractor certifies further that he will not maintain or provide for his employees any segregated facilities at any of his establishments, and that he will not permit his employees to perform their services at any location, under his control, where segregated facilities are maintained. The federally assisted construction contractor agrees that a breach of this certification is a violation of the Equal Opportunity clause in this contract. As used in this certification, the term "segregated facilities" means any waiting rooms, work areas, rest rooms and other storage or dressing areas, parking lots, drinking fountains, recreation or entertainment areas, transportation, and housing facilities provided for employees which are segregated by explicit directive or are in fact segregated based on race, creed, color, or national origin, because of habit, local custom or otherwise. The federally assisted construction contractor agrees that (except where he has obtained identical certifications from proposed subcontractors for specific time periods) he will obtain identical certifications from proposed subcontractors prior to the award of subcontracts exceeding \$10,000 which are not exempt from the provisions of the Equal Opportunity clause, and that he will retain such certification in his files.

Signature

Date

Name and Title of Signer

(Please type)

Firm Name

NOTE: The penalty for making false statements in offers is prescribed in 18 U.S.C. 1001.

NOTICE TO LABOR UNIONS OR OTHER ORGANIZATIONS OF WORKERS

NONDISCRIMINATION IN EMPLOYMENT

To: _____
(Name of union or organization of workers)

The undersigned currently holds contract(s) with _____
(name of applicant)

involving funds or credit of the U.S. Government or (a) subcontract(s) with a prime contractor holding such contract(s).

You are advised that under the provisions of the above contracts(s) or subcontract(s) and in accordance with Executive Order 11246, as amended, dated September 24, 1965, as amended, the undersigned is obliged not to discriminate against any employee or applicant for employment because of race, color, creed or national origin. This obligation not to discriminate in employment includes, but is not limited to, the following:

HIRING, PLACEMENT, UPGRADING, TRANSFER OR DEMOTION, RECRUITMENT, ADVERTISING, OR SOLICITATION FOR EMPLOYMENT, TRAINING DURING EMPLOYMENT, RATES OF PAY OR OTHER FORMS OF COMPENSATION, SELECTION FOR TRAINING INCLUDING APPRENTICESHIP, LAYOFF OR TERMINATION.

This notice is furnished you pursuant to the provisions of the above contract(s) or subcontracts(s) and Executive Order 11246, as amended.

Copies of this notice will be posted by the undersigned in conspicuous places available to employees or applicants for employment.

(Contractor or Subcontractor)

(Date)

EPA Project Control #: _____

United States Environmental Protection Agency
Washington, DC 20460

Certification Regarding Debarment, Suspension and Other Responsibility Matters

The prospective participant to the best of its knowledge and belief that it and its principles:

- (a) Are not presently debarred, suspended, proposed for debarment, declared ineligible, or voluntarily excluded from covered transactions by any Federal department or agency;
- (b) Have not within a three year period preceding this proposal been convicted of or had a civil judgment rendered against them for commission of fraud or a criminal offense in connection with obtaining, attempting to obtain, or performing a public (Federal, State or local) transaction or contract under a public transaction; violation of Federal or State antitrust statutes or commission of embezzlement, theft, forgery, bribery, falsification or destruction of records, making false statements, or receiving stolen property.
- (c) Are not presently indicted for or otherwise criminally or civilly charged by a government entity (Federal, State or local) with commission of any of the offenses enumerated in paragraph (1) (b) of this certification; and
- (d) Have not within a three-year period preceding this application/proposal had one or more public transactions (Federal, State or local) terminated for cause or default.

I understand that a false statement on this certification may be grounds for rejection of this proposal or termination of the award. In addition, under 18 USC Sec. 1001, a false statement may result in fine of up to \$10,000 or imprisonment for up to 5 years, or both.

(Typed Name & Title of Authorized Representative)

(Signature of Authorized Representative) (Date)

I am unable to certify the above statements. My explanation is attached.

Instructions

Under Executive Order 12549 an individual or organization debarred or excluded from participation in Federal assistance or benefit programs may not receive any assistance award under a Federal program, or a sub-agreement thereunder for \$25,000 or more.

Accordingly, each prospective recipient of an EPA grant, loan, or cooperative agreement and any contract or sub-agreement participant thereunder must complete the attached certification or provide an explanation why they cannot. For further details, see 40 CFR 32.510, Participants' responsibilities, in the attached regulation.

Where to Submit

The prospective EPA grant, loan, or cooperative agreement recipient must return the signed certification or explanation with its application to the appropriate EPA Headquarters or Regional office, as required in the application instructions.

A prospective prime contractor must submit a completed certification or explanation to the individual or organization awarding the contract.

Each prospective subcontractor must submit a completed certification or explanation to the prime contractor for the project.

How to Obtain Forms:

EPA includes the certification form, instructions, and a copy of its implementing regulation (40 CFR Part 32) in each application kit. Applicants may reproduce these materials as needed and provide them to their prospective prime contractor, who, in turn, may reproduce and provide them to prospective subcontractors.

Additional copies/assistance may be requested from:

Compliance Branch
Grants Administration Division (PM-216F)
U.S. Environmental Protection Agency
401 M Street, SW
Washington DC 20460
(Telephone: 202-475-8025)

**Construction Contracts of Loan Recipient and Other Sections From
"Procedures for Issuing Loans from the Public Water Supply Loan Program"**

Section 662.420(b)(2) Change Orders

- A) When the loan recipient authorizes the contractor to add, delete, or revise the work within the general scope of the contract documents, or authorizes an adjustment in the contract price or contract time, the loan recipient shall submit a change order to the Agency.
- B) For each change order, the loan recipient shall submit to the Agency for approval the following documentation:
 - i) one copy of the fully executed change order signed by the loan recipient, construction engineer, and the contractor; and
 - ii) a description of any changes, with justification for the changes.
- C) Prior approval by the Agency of a change order is required when a change order results in:
 - i) alterations in design scope that require a modification to a construction permit; or
 - ii) an increase in the amount of loan funds needed to complete the project.
- D) Failure to give timely notice of proposed project changes or action by the loan recipient that is not consistent with the Agency's determination on those changes may result in disallowance of loan participation for costs incurred that are attributable to the change.

Section 662.620(f) Required Construction Contract Provisions

Each construction contract shall include the following provisions:

- 1) Audit; access to records:
 - A) The contractor shall maintain books, records, documents and other evidence directly pertinent to performance on loan work in accordance with Generally Accepted Accounting Principles (GAAP). The contractor shall also maintain the financial information and data used by the contractor in the preparation or support of any cost submissions required under Section 365.420 (b)(2) of the loan rules and a copy of the cost summary submitted to the owner. The Illinois Auditor General, the owner, the Agency, or any of their authorized representatives shall have access to the books, records, papers, documents, and other evidence for purposes of inspection, audit, examination, excerpts, transcriptions, and copying. The contractor shall provide facilities for access and inspection.
 - B) For a formally advertised, competitively awarded, fixed price contract, the contractor shall include access to records as required by subsection (a)(1)(A) for all negotiated

change orders and contract amendments in excess of \$25,000 that affect the contract price. In the case of all other prime contracts, the contractor shall agree to include access to records required by subsection (a)(1)(A) in all contracts and all tier subcontracts or change orders in excess of \$25,000 that are directly related to project performance.

- C) Audits shall be in accordance with auditing standards generally accepted in the United States.
- D) The contractor shall agree to the disclosure of all information and reports resulting from access to records required by subsection (a)(1)(A). When the audit concerns the contractor, the auditing agency shall afford the contractor an opportunity for an audit exit conference and an opportunity to comment on the pertinent portions of the draft audit report. The final audit report shall include the written comments, if any, of the audited parties.
- E) The records required by subsection (a)(1)(A) shall be maintained and made available during performance of the work under the loan agreement and for 3 years after the date of the final loan audit. In addition, records that relate to any dispute or litigation or the settlement of claims arising out of any performance, costs or items to which an audit exception has been taken, shall be maintained and made available for 3 years after resolution of the dispute, appeal, litigation, claim or exception.
- F) The right of access will generally be exercised with respect to financial records under:
 - i) Negotiated prime contracts;
 - ii) Negotiated change orders or contract amendments in excess of \$25,000 affecting the price of any formally advertised, competitively awarded, fixed price contract; and
 - iii) Subcontracts or purchase orders under any contract other than a formally advertised, competitively awarded, fixed price contract.
- G) The right of access will generally not be exercised with respect to a prime contract, subcontract, or purchase order awarded after effective price competition. In any event, the right of access shall be exercised under any type of contract or subcontract:
 - i) With respect to records pertaining directly to contract performance, excluding any financial records of the contractor; and
 - ii) If there is any indication that fraud, gross abuse, or corrupt practices may be involved in the award or performance of the contract or subcontract.

2) Covenant against contingent fees.

The contractor shall warrant that no person or selling agency has been employed or retained to solicit or secure the contract upon an agreement or understanding for a commission, percentage, brokerage, or contingent fee. For breach or violation of this warranty, the owner shall have the right to annul the contract without liability or in its discretion to deduct from the contract price or consideration, or otherwise recover, the full amount of such commission, percentage, brokerage, or contingent fee.

3) Wage provisions.

The Contractor shall pay prevailing wages in accordance with the Davis-Bacon Act (40 USC 3141 through 3148) as defined by the U.S. Department of Labor.

4) Disadvantaged business enterprise requirements.

The contractor shall provide evidence that the contractor has taken affirmative steps in accordance with 40 CFR 33 to assure that disadvantaged business enterprises are used when possible as sources of supplies, equipment, construction, and services, consistent with the provisions of the Agency's Operating Agreement with USEPA.

5) Debarment and suspension provisions.

The contract shall require the successful bidders to submit a Certificate Regarding Debarment, Suspension and Other Responsibility Matters (EPA Form 5700-49) showing compliance with federal Executive Order 12549.

6) Nonsegregated facilities provisions

The contractor shall be required to submit a Certification of Nonsegregated Facilities on forms provided by the Agency.

7) American Iron and Steel

The contractor shall be required to use American Iron and Steel, if required by USEPA for that fiscal year.

8) A clause that provides:

"No contractor or subcontractor shall discriminate on the basis of race, color, national origin or sex in the performance of this contract. The contractor or subcontractor shall carry out applicable requirements of 40 CFR 33 in the award and administration of contracts awarded under the PWSLP. Failure by the contractor or subcontractor to carry out these requirements is a material breach of this contract which may result in the termination of this contract or other legally available remedies."

Section 662.620(g) Subcontracts Under Construction Contracts

The award or execution of all subcontracts by a prime contractor and the procurement and negotiation procedures used by the prime contractor shall comply with:

- 1) All applicable provisions of federal, State and local law;
- 2) All provisions of this Part 662 regarding fraud and other unlawful or corrupt practices;
- 3) All provisions of this Part 662 with respect to access to facilities, records and audit of records; and
- 4) All provisions of subsection 662.620(f)(5) that require a Certification Regarding Debarment, Suspension, and Other Responsibility Matters (EPA Form 5700-49) showing compliance with any controlling federal Executive Orders.

Section 662.620(h) Contractor Bankruptcy

In the event of a contractor bankruptcy, the loan recipient shall notify the Agency and shall keep the Agency advised of any negotiations with the bonding company, including any proposed settlement. The Agency may participate in those negotiations and will advise the loan recipient of the impact of any proposed settlement to the loan agreement. The loan recipient shall be responsible for assuring that every appropriate procedure and incidental legal requirement is observed in advertising for bids and re-awarding a construction contract.

Section 662.620(i) Access

Every contract entered by the loan recipient for construction work, and every subagreement, shall provide the Agency representatives with access to the work. The contractor or subcontractor shall provide facilities for such access and inspection.

Section 662.640(c) Remedies

All claims, counter-claims, disputes and other matters in question between the recipient and the contractor arising out of, or relating to, a subagreement or its breach shall be decided by arbitration if the parties agree, or in a court of competent jurisdiction within the State.

Bidder Certification
In Compliance with Article 33E-11 to the
"Criminal Code of 2012"

I _____, do hereby certify that:

1. I am _____ of the _____
Name Position Firm
and have authority to execute this certification on behalf of the firm

2. This firm is not barred from bidding on this contract due to a either a Bid-rigging or Bid Rotating violation as set forth in Article 33E-11 to the "Illinois Criminal Code of 2012 [720 ILCS 5/33E-11]."

Name of Firm _____

Signature _____

Title _____

Date _____

Corporate Seal (where appropriate)

On this _____ day of _____ 20____, before me appeared (Name)

_____ to me personally known,
who, being duly sworn, did execute the foregoing affidavit, and did state that he or she was properly authorized by (Name of Firm) _____ to execute the affidavit and did so as his or her free act and deed.

Notary Public _____ Commission Expires _____

Notary Seal

Specifications for Disadvantaged Business Enterprise Participation

(Name of Loan Recipient) _____

I. Disadvantaged Business Enterprise Policy

- A. It is the policy of the State of Illinois to award a fair share of sub-agreements to disadvantaged businesses (DBEs). In complying with this requirement, contractors are required to take affirmative steps to assure that disadvantaged businesses are used when possible as sources of supplies, equipment, construction, and services as explained herein.
- B. These specifications define the terms, conditions, and requirements of the State Revolving Fund Loan Program, and the (Name of Loan Recipient) _____'s policy and procedures for complying with these requirements.
- C. As required by the award conditions of USEPA's Assistance Agreement with IEPA, the fair share percentages are 5% for MBEs and 12% for WBEs.

II. Pre-Contract Award Obligations

- A. All bidders are required to advertise subcontracting opportunities and to negotiate with disadvantaged businesses prior to bid opening. Failure to document such affirmative efforts shall be deemed, relative to disadvantaged business compliance, non-responsive.
- B. To establish a bid as responsible, the bidder will be required to document the proposed utilization of disadvantaged businesses with letters of intent signed by the bidder and by the disadvantaged business listed in the bid. The documentation requirements are outlined in Section III of this document.
- C. (Name of Loan Recipient) _____'s disadvantaged business policy clearly intends for bidders to contact and encourage the participation of disadvantaged businesses prior to bid opening. Affirmative efforts (the written record of conscientious and honest communications between the bidder and disadvantaged business) must be initiated and completed by the bidder prior to bid opening. All bidders must document compliance with the requirements of the disadvantaged business policy.

III. Evaluation of Disadvantaged Business Utilization and Affirmative Efforts

- A. As a prerequisite to demonstrate compliance with the (Name of Loan Recipient) _____'s disadvantaged business policy, ALL bidders shall provide the following with its bid:
 - 1. Completed and signed certification from the bidder(s), attesting that the bidder will award no sub-agreements, including the procurement of equipment, materials, supplies and services, in the performance of this contract.

OR

2. "Certification of publication," or adequate proof of publication, including an actual copy of the newspaper advertisement from a daily newspaper. **The advertisement must run one day at least (16) days prior to bid opening.** An example advertisement follows this section.

Bidders may publish the advertisement in an established, online bidder's clearinghouse such as the "Dodge Report (<http://construction.com/dodge/>)". If an online advertisement is placed with the "Dodge Report" or an equivalent website, a screenshot of the advertisement along with the webpage address, and a payment receipt is required as documentation. **The advertisement must run one day at least (16) days prior to bid opening.**

3. List of all disadvantaged business enterprise (DBE) and non-DBE's that submitted proposals to the bidder along with the date of the proposal. Names, addresses, phone number and/or e-mail are required.
4. List of disadvantaged businesses not being utilized and justification for non-utilization.
5. If DBE subcontractors will be utilized for the project, a completed and signed copy of IEPA DBE Form No. 3 (DBE Subcontractor Utilization Form) or an equivalent "Notice of Intent" is needed from each subcontractor.
6. If DBE subcontractors will be utilized for the project, a completed and signed certification from the bidder(s), attesting that the bidder has no controlling or dominating interest or conflict of interest with the disadvantaged business that will be utilized.
7. In instances where the bidder(s) does not receive any proposals from disadvantaged businesses prior to bid opening, the bidder(s) must provide a written certification attesting that no proposals were received.

Failure to submit the documentation pursuant to the requirements of A (1-7) above may cause rejection of the bid as non-responsive.

IV. Sanctions

- A. The (Name of Loan Recipient) _____ has the option to reject one or all bids when the information submitted by the bidder(s) fails to demonstrate compliance with the disadvantaged business requirements (i.e., the bidder fails to place their pre-bid advertisement in a daily newspaper, or approved website, at least 16 days prior to bid opening).
- B. Upon finding that any Party has not complied with the requirements of these specifications, including misrepresenting a firm as a disadvantaged business, any one or a combination of the following actions may be taken.
 1. Declare the bidder and/or subcontractor non-responsive and therefore, ineligible for contract award.
 2. Disallow all contract costs associated with non-compliance.

3. Refer matters which may be fraudulent to the Illinois Attorney General.

V. Post-Contract Award Compliance

- A. As required by the award conditions of USEPA's Assistance Agreement with IEPA, all sub-agreements of the prime contractor must identify that the fair share percentages are 5% for MBEs and 12 % for WBEs.
- B. After award of the prime contract, copies of all disadvantaged business-related sub-agreements between the prime contractor and subcontractors shall be submitted to the owner.
- C. After bid submission, any changes in previously reported disadvantaged businesses utilization shall be handled in accordance with 40 CFR Part 33.302(b-h). If the contractor fails to initiate such actions, the owner may withhold payments and/or institute other appropriate sanctions.

**Suggested Disadvantaged Business (DBE)
Advertisement for Construction Contractors**

Notice to Disadvantaged Businesses

_____, _____, _____, is
(Name of Company) (Address of Company) (Telephone)

seeking disadvantaged businesses for the _____
(Name of Loan Recipient)

Project for subcontracting opportunities in the following areas: _____,
_____, _____

All disadvantaged businesses should contact, **IN WRITING**, (certified letter, return receipt requested),
_____ to discuss the subcontracting opportunities. All negotiations must
(Company Contact Person)

be completed prior to bid opening _____.
(Date of Bid Opening)

*The advertisement must clearly state the method of evaluating the proposals or quotations, and the relative importance attached to each criterion. Bidders must uniformly and objectively evaluate the proposals submitted by disadvantaged business in response to the advertisement based upon the evaluation criteria stated in the advertisement. The evaluation criteria must not be restrictive or exclusionary.

Summary Report of Disadvantaged Business Enterprise Requirements for Contractors

- 1) Completed and signed certification from bidder(s), attesting that the bidder will award no sub-agreements, including the procurement of equipment, materials, supplies and services in the performance of this contract (may use IEPA DBE Form #1).

OR

"Certificate of publication, or adequate evidence of proof of publication, including an actual copy of the newspaper advertisement from a daily publication. For advertisements placed in a construction project clearinghouse such as www.construction.com, a screenshot of the advertisement, link to website, and receipt is required for proof of advertising.

- 2) List of all disadvantaged business enterprises (DBE) and non-DBE's that submitted proposals to the bidder/prime contractor. Specify as DBE or non-DBE, type of DBE, and the other information listed below (DBE Form #4 may be used for this purpose).

Name of Company
 Name of Owners
 Address of Company
 E-mail Address of Company
 Telephone Number
 Date of Proposal
 Type of Business
 Type of DBE
 Description of work to be performed

- 3) List of disadvantaged businesses that submitted proposals to the bidder but will not be utilized. Justification for non-utilization must be provided (may use IEPA DBE Form #1).
- 4) Completed and signed copies IEPA DBE Form #3 (Subcontractor Utilization Form) or equivalent "Notice of Intent". Only applies if using DBE subcontractors.
- 5) Completed and signed certification from bidder(s) attesting that the bidder has no dominating or conflict of interest with the disadvantaged business to be utilized (IEPA DBE Form #1). Only applies if using DBE subcontractors.
- 6) In instances where the bidder(s) does not receive any proposals from disadvantaged businesses prior to bid opening, the bidder(s) must provide a written certification attesting that no proposals were received (IEPA DBE Form #1).
- 7) **Note:** DBE Form #2 is **not** included in this packet. It is for consultants/engineers to report DBE activity. This form may be found in IEPA's DBE Guidance Manual which is available on the Agency's website or mailed upon request by calling 217-782-2027.

IEPA Disadvantaged Business Enterprise (DBE) Program Form #1 Contractor Certification Form

(To be completed by all Prime Contractors)

Please check the appropriate boxes that apply and complete the information on the bottom of the form.

- This firm will award no subcontracts (including in the procurement of equipment, supplies, or services), in the performance of this contract.

- This firm advertised for DBE subcontractors according to the good faith efforts outlined in the IEPA DBE Guidance Document.

- This firm received proposals from DBE(s) that will not be utilized. A list of the DBEs not hired, along with their address, phone number, and reason(s) for non-utilization, is below.

- This firm did not receive any inquiries from DBEs.

I certify that the above is true. I further certify that this firm and its partners, directors, and officers do not possess a controlling interest in ownership or conflict of interest or any other authority to control the DBE to be used during the performance of the contracts.

By: _____
NAME: _____
TITLE: _____
Company: _____

Date: ___/___/_____

EPA Disadvantaged Business Enterprise (DBE) Program Form #3 Subcontractor Utilization Form

(Only complete this form if DBE subcontractors or sub-consultants will be working on a project)

This form is intended to capture the DBE subcontractor’s description of work to be performed and the price of the work submitted to the prime contractor. All subcontractors must complete this form, and it must be included in the prime contractor’s bid package.

Subcontractor Name	Project Name
Contact Person’s Name & Title	
Address	
Telephone	Email
DBE Certified By:	Select all that apply. At least one is required: MBE WBE SBE DBE
Prime Contractor Name	
Type of Work to be Performed	Cost Estimate of Work

I certify under penalty of perjury that the forgoing statements are true and correct. Signing this form does not signify a commitment to using the subcontractors above. I am aware that in the event of a replacement of a subcontractor, I will adhere to the replacement requirements set forth in 40 C.F.R. Part 33 Section 33.302(c).

Prime Contractor Signature:	Print Name:
Date:	Title:
Subcontractor Signature:	Print Name:
Date:	Title:

IEPA Disadvantaged Business Enterprise (DBE) Program Form #4, Bidders List
(Only complete this form if subcontractors or sub-consultants will be working on a project)

Using this form/format is optional. Other formats are acceptable.

Company Name & Contact Person	Address	Phone No. w/ area code	Email	Proposed Work (supplies, paint, paint etc.)	DBE Status (MBE, WBE, DBE, SBE)
					<p align="center">Check if Hired</p> <p align="center"><input type="checkbox"/></p>
					<p align="center">Check if Hired</p> <p align="center"><input type="checkbox"/></p>
					<p align="center">Check if Hired</p> <p align="center"><input type="checkbox"/></p>
					<p align="center">Check if Hired</p> <p align="center"><input type="checkbox"/></p>

**Bidder Certification Regarding the Use of
American Iron and Steel Products**

I _____, do hereby certify that:
Name

1. I am _____ (title) of the _____ (company, partnership, etc.) and have authority to execute this certification on behalf of the firm.
2. This firm is aware that all iron and steel products used for this project must be produced in the United States per Section 436 (a) – (f) of the Consolidated Appropriations Act, 2014.
3. This firm is aware that the use of American iron and steel products applies to all projects for the construction, alteration, maintenance, or repair of publically owned treatment works (POTW) or public water systems.
4. This firm understands the term “iron and steel products” refers to the following products made primarily of iron or steel: lined or unlined pipes and fittings, manhole covers and other municipal castings, hydrants, tanks, flanges, pipe clamps and restraints, valves, structural steel, reinforced precast concrete, and construction materials.
5. I am aware that this requirement applies to all portions of the project that are subcontracted.

Name of Company _____

Signature _____

Title _____

Date _____

Corporate Seal (where appropriate)

Requirements Specific to American Iron and Steel

The Consolidated Appropriations Act of 2014 (Public Law 113-76) first included an "American Iron and Steel (AIS)" requirement that requires Clean Water State Revolving Fund (CWSRF) and Drinking Water State Revolving Fund (DWSRF) loan recipients to use iron and steel products that are produced in the United States for projects involving the construction, alteration, maintenance, or repair of a public water system or treatment works if the project is funded through a CWSRF or a DWSRF loan. Guidance is available on USEPA's website: http://water.epa.gov/grants_funding/aisrequirement.cfm. Waivers from the requirements are available under certain circumstances.

For CWSRF or DWSRF purposes, an iron or steel product is one of the following made primarily of iron or steel that is permanently incorporated into the public water system or treatment works:

- Pipes (lined or unlined) and fittings;
- Manhole Covers;
- Municipal Castings (defined in more detail below);
- Hydrants;
- Tanks;
- Flanges;
- Pipe clamps and restraints;
- Valves;
- Structural steel (defined in more detail below);
- Reinforced precast concrete; and
- Construction materials (defined in more detail below).

For one of the listed products to be considered subject to the AIS requirements, it must be made of greater than 50% iron or steel, measured by costs. The cost should be based on the material costs.

For the purposes of AIS, steel means an alloy that includes at least 50 percent iron, between .02 and 2 percent carbon, and may include other elements. Metallic elements such as chromium, nickel, molybdenum, manganese, and silicon may be added during the melting of steel for the purpose of enhancing properties such as corrosion resistance, hardness, or strength. The definition of steel covers carbon steel, alloy steel, stainless steel, tool steel and other specialty steels.

For the purposes of AIS, production in the United States of the iron or steel products used in the project requires that all manufacturing processes, including application of coatings, must take place in the United States, except for metallurgical processes involving refinement of steel additives. All manufacturing processes includes processes such as melting, refining, forming, rolling, drawing, finishing, fabricating and coating. Further, if a domestic iron and steel product is taken out of the US for any part of the manufacturing process, it becomes foreign source material. However, raw materials such

as iron ore, limestone and iron and steel scrap are not covered by the AIS requirement, and the material(s), if any, being applied as a coating are similarly not covered. Non-iron or steel components of an iron and steel product may come from non-US sources. For example, for products such as valves and hydrants, the individual non-iron and steel components do not have to be of domestic origin. Raw materials, such as iron ore, limestone, scrap iron, and scrap steel, can come from non-US sources.

For AIS, municipal castings are cast iron or steel infrastructure products that are melted and cast. They typically provide access, protection, or housing for components incorporated into utility owned drinking water, storm water, wastewater, and surface infrastructure. They are typically made of grey or ductile iron, or steel. Examples of municipal castings are:

Access Hatches;	Drainage Greates, Frames and Curb Inlets;
Ballast Screen;	Inlets;
Benches (Iron or Steel);	Junction Boxes;
Bollards;	Lampposts;
Cast Bases;	Manhole Covers, Rings and Frames, Risers;
Cast Iron Hinged Hatches, Square and Rectangular;	Meter Boxes;
Cast Iron Riser Rings;	Service Boxes;
Catch Basin Inlet;	Steel Hinged Hatches, Square & Rectangular;
Cleanout/Monument Boxes;	Steel Riser Rings;
Construction Covers and Frames;	Trash receptacles;
Curb and Corner Guards;	Tree Grates;
Curb Openings;	Tree Guards;
Detectable Warning Plates;	Trench Grates; and
Downspout Shoes (Boot, Inlet);	Valve Boxes, Covers and Risers.

For AIS, structural steel is rolled flanged shapes, having at least one dimension of their cross-section three inches or greater, which are used in the construction of bridges, buildings, ships, railroad rolling stock, and for numerous other constructional purposes. Such shapes are designated as wide-flange shapes, standard I-beams, channels, angles, tees and zebs. Other shapes include H-piles, sheet piling, tie plates, cross ties, and those for other special purposes.

For AIS, construction materials are those articles, materials, or supplies made primarily of iron and steel, that are permanently incorporated into the project, not including mechanical and/or electrical components, equipment and systems. Some of these products may overlap with what is also considered "structural steel." This includes, but is not limited to, the following products: wire rod, bar, angles, concrete reinforcing bar, wire, wire cloth, wire rope and cables, tubing, framing, joists, trusses, fasteners (i.e., nuts and bolts), welding rods, decking, grating, railings, stairs, access ramps, fire escapes, ladders, wall panels, dome structures, roofing, ductwork, surface drains, cable handing systems, manhole steps, fencing and fence tubing, guardrails, doors, and stationary screens.

For the purposes of AIS, mechanical and electrical components, equipment and systems are not considered construction materials. Mechanical equipment is typically that which has motorized parts and/or is powered by a motor. Electrical equipment is typically any machine powered by electricity and includes components that are part of the electrical distribution system.

There are specific requirements for precast concrete to comply with AIS. While reinforced precast concrete may not be at least 50% iron or steel, in this case, the reinforcing bar and wire must be produced in the US and meet the same standards as for any other iron or steel product. Additionally, the casting of the concrete product must take place in the US. The cement and other raw materials used in concrete production are not required to be of domestic origin. If the reinforced concrete is cast at the construction site, the reinforcing bar and wire are considered a construction material and must be produced in the US.

Recordkeeping for Iron and Steel Products: Documenting the Country of Origin for Iron and Steel Products for Loan Programs

Loan recipients with assistance from their general contractor must be able to verify that products used in their projects comply with the AIS requirements. USEPA recommends loan recipients use a “Step Certification” process to ensure that producers adhere to the AIS requirements. Step certification is a process under which each handler (supplier, fabricator, manufacturer, etc.) of the iron and steel products certifies that their step in the process was domestically performed. Each time a step in the manufacturing process takes place, the manufacturer delivers its work along with a certification of its origin. A certification can be quite simple if it includes the name of the manufacturer, the location of the manufacturing facility (not company headquarters), a description of the product or item being delivered, and a signature by a manufacturer’s responsible party. An example of this type of certification is attached.

Certification could be achieved by other methods such as requiring the final manufacturer, who delivers the iron/steel products to the worksite, to provide certification that all manufacturing processes occurred in the US. While this type of certification is easier and acceptable, it may not provide the same degree of assurance and additional documentation may be needed. USEPA auditors recommend keeping records of when and where the products were delivered. Examples include: Perry Water Plant on August 3, 2017, or Jankousky Construction Offices on October 5, 2017. Records from the manufacturer should refer to specific items such as pipes, valves, meters. Try to avoid records containing broad statements such as, “All products delivered were made in the USA.”

Regardless of the method, documents regarding the country of origin for iron and steel products should be collected and maintained by all loan recipients. Having a good paper trail is invaluable during an inspection or audit. Information is available at <http://www.epa.illinois.gov/topics/grants-loans/water-financial-assistance/state-revolving-fund/guidance/index>.

Sample Certification Letter

The following information is provided as a sample letter of step certification for AIS compliance. The completed letter is provided to the construction contractor or loan applicant from the supplier, fabricator, manufacturer, etc. of iron and steel products. Documentation must be provided on company letterhead. If e-mail is used, documents should be scanned so the company letterhead is visible.

Company Letterhead

Date

Company Name
Company Address
City, State, Zip

Subject: American Iron and Steel Step Certification for Project (xxx ***Identify Project Here*** xxx)

I, (company representative), certify that the (melting, bending, coating, galvanizing, cutting, etc.) process for (manufacturing or fabricating) the following products and/or materials shipped or provided for the subject project is in full compliance with the American Iron and Steel requirements as mandated in EPA's State Revolving Fund Programs.

Item, Products, and/or Materials:

1. XXX
2. XXX
3. XXX

Such process took place at the following location (City and State must be included):

If any of the above compliance statements change while providing material to the project we will immediately notify the prime contractor and the engineer.

Signed by Company Representative

Illinois Works Jobs Program Act – Apprenticeship Initiative
Information for Contractors

Summary: The Illinois Works Jobs Program Act, 30 ILCS 559/Art. 20, is a statewide initiative to ensure that all Illinois residents have access to State capital projects and careers in the construction industry and building trades and to provide contracting and employment opportunities to historically underrepresented populations in the construction industry. This will be accomplished through three programs created by the Illinois Works Jobs Program Act: the Illinois Works Apprenticeship Initiative, the Illinois Works Pre-Apprenticeship Program, and the Illinois Works Bid Credit Program. Additional information is available at the following website:

<https://www2.illinois.gov/dceo/WorkforceDevelopment/Pages/IllinoisWorksJobsProgramAct.aspx>.

The goal of the Illinois Works Apprenticeship Initiative (“10% apprenticeship goal”) is that for projects estimated to cost \$500,000 or more, apprentices will perform either 10% of the total labor hours actually worked in each prevailing wage classification or 10% of the estimated labor hours in each prevailing wage classification, whichever is less. The 10% apprenticeship goal applies to projects being paid for in whole or in part by appropriated capital funds to construct a public work either through a contract or grant issued by a State agency. A determination was made that this requirement also applies to IEPA loans. The \$500,000 threshold applies to the total project cost and NOT the total cost or value of an individual construction contract.

Certification: Apprentices are required to be U.S. Dept. of Labor certified (not limited to pre-apprentice program graduates).

Applicability

If a project is estimated to received \$500,000 or more of State Capital Funding for the Project:

If the state’s contribution to the project amount equals 50% or more of the cost for the project, the 10% apprenticeship requirement applies to all prevailing wage eligible work performed by contractors on the public works project.

If the state’s contribution to the project is less than 50% of the cost for the project, the 10% apprenticeship requirement applies only to prevailing wage eligible work being funded from state funds.

The Project has less than \$500,000 of State Capital Funding, but the Total Estimated Project Cost is \$500,000 or more:

If the state’s contribution to the project amount equals 50% or more of the estimated cost for the project, the 10% apprenticeship requirement applies to all prevailing wage eligible work performed by contractors on the public works project.

If the state’s contribution to the project is less than 50% of the estimated cost for the project, the 10% apprenticeship requirement does not apply.

Total Estimated Project Cost is less than \$500,000: The 10% apprenticeship requirement does not apply. The \$500,000 threshold applies to the total project cost and NOT the total cost or value of an individual construction contract.

Waivers from the Requirements: If goals cannot be met, the state has discretion to grant waivers, reductions or to hold public hearings on the issue. Factors to be considered include the scale of the project and whether the contractor or subcontractor seeking the action has previously requested reductions or waivers. A waiver form is available on the IEPA website at:

<https://epa.illinois.gov/content/dam/soi/en/web/epa/topics/grants-loans/state-revolving-fund/documents/WAIVER-REQUEST.pdf> . The form can also be obtained from DCEO.

Reporting: An example quarterly reporting form is attached. A fillable version is available on the IEPA website. Contractors should coordinate with the loan applicant and their consultant for further instructions regarding these forms. Loan applicants are ultimately responsible for reporting quarterly labor hours to the state, but coordination with their contractor is essential. All loan funded projects are subject to payment of Davis Bacon wages.

For general apprenticeship questions, please contact the Illinois Works Office at:
CEO.ILWorks@Illinois.gov.

Illinois Works Apprenticeship Initiative Periodic Grantee Report

Organization Name		FEIN Number		DUNS Number	
Grant Awarding Agency		Project Start Date		Project End Date	
Grant Number		Estimated Total Project Costs		Estimated Total State Contribution	

Reporting Period: Period Start Date Period End Date

Applicable Apprenticeship Goal (Select all that apply):

10% total project cost 10% total state contribution only

Waiver Approved by IL DCEO IL DCEO Waiver Approval Date

(If a waiver was granted for any prevailing wage classification, the Grantee does not need to report on those classifications on this form.)

Reduction Approved by IL DCEO IL DCEO Reduction Approval Date

(If selected, enter the applicable prevailing wage classification(s) and approved reduced percentage(s).)

Prevailing Wage Classification	Reduced Percentage		Prevailing Wage Classification	Reduced Percentage

Illinois Works Apprenticeship Initiative Periodic Grantee Report

Please provide information in this chart for the entire project if the apprenticeship goal applies to the entire project.
Provide information for only the state contribution if the apprenticeship goal applies only to state appropriated capital funds.

Prevailing Wage Classification	Total Hours for Classification in Reporting Period	Total Apprenticeship Hours for Classification in Reporting Period	% of Apprenticeship Hours	Total Hours for Classification (Cumulative from Start of the Project)	Total Apprenticeship Hours (Cumulative from Start of the Project)	% of Apprenticeship Hours (Cumulative from Start of the Project)	If no apprenticeship hours recorded, explain.

Organization Certification and State Agency Acknowledgement

1. Organization Certification:

By signing this form, I certify to the best of my knowledge and belief that the form is true, complete and accurate and that any false, fictitious or fraudulent information or the omission of any material fact could result in the immediate termination of my grant award(s).

Institution/Organization Name:

Printed Name (Executive Director or equivalent):

Title (Executive Director or equivalent):

Signature (Executive Director or equivalent):

Date/Time Field

2. State Agency Acknowledgement:

State Agency

Printed Name

Title

Signature:

Date/Time Field

Requirements Specific to American Iron and Steel

The Consolidated Appropriations Act of 2014 (Public Law 113-76) first included an "American Iron and Steel (AIS)" requirement that requires Clean Water State Revolving Fund (CWSRF) and Drinking Water State Revolving Fund (DWSRF) loan recipients to use iron and steel products that are produced in the United States for projects involving the construction, alteration, maintenance, or repair of a public water system or treatment works if the project is funded through a CWSRF or a DWSRF loan. Guidance is available on USEPA's website: http://water.epa.gov/grants_funding/aisrequirement.cfm. Waivers from the requirements are available under certain circumstances.

For CWSRF or DWSRF purposes, an iron or steel product is one of the following made primarily of iron or steel that is permanently incorporated into the public water system or treatment works:

- Pipes (lined or unlined) and fittings;
- Manhole Covers;
- Municipal Castings (defined in more detail below);
- Hydrants;
- Tanks;
- Flanges;
- Pipe clamps and restraints;
- Valves;
- Structural steel (defined in more detail below);
- Reinforced precast concrete; and
- Construction materials (defined in more detail below).

For one of the listed products to be considered subject to the AIS requirements, it must be made of greater than 50% iron or steel, measured by costs. The cost should be based on the material costs.

For the purposes of AIS, steel means an alloy that includes at least 50 percent iron, between .02 and 2 percent carbon, and may include other elements. Metallic elements such as chromium, nickel, molybdenum, manganese, and silicon may be added during the melting of steel for the purpose of enhancing properties such as corrosion resistance, hardness, or strength. The definition of steel covers carbon steel, alloy steel, stainless steel, tool steel and other specialty steels.

For the purposes of AIS, production in the United States of the iron or steel products used in the project requires that all manufacturing processes, including application of coatings, must take place in the United States, except for metallurgical processes involving refinement of steel additives. All manufacturing processes includes processes such as melting, refining, forming, rolling, drawing, finishing, fabricating and coating. Further, if a domestic iron and steel product is taken out of the US for any part of the manufacturing process, it becomes foreign source material. However, raw materials such as iron ore, limestone and iron and steel scrap are not covered by the AIS requirement, and the material(s), if any,

being applied as a coating are similarly not covered. Non-iron or steel components of an iron and steel product may come from non-US sources. For example, for products such as valves and hydrants, the individual non-iron and steel components do not have to be of domestic origin. Raw materials, such as iron ore, limestone, scrap iron, and scrap steel, can come from non-US sources.

For AIS, municipal castings are cast iron or steel infrastructure products that are melted and cast. They typically provide access, protection, or housing for components incorporated into utility owned drinking water, storm water, wastewater, and surface infrastructure. They are typically made of grey or ductile iron, or steel. Examples of municipal castings are:

Access Hatches;	Drainage Greates, Frames and Curb Inlets;
Ballast Screen;	Inlets;
Benches (Iron or Steel);	Junction Boxes;
Bollards;	Lampposts;
Cast Bases;	Manhole Covers, Rings and Frames, Risers;
Cast Iron Hinged Hatches, Square and Rectangular;	Meter Boxes;
Cast Iron Riser Rings;	Service Boxes;
Catch Basin Inlet;	Steel Hinged Hatches, Square & Rectangular;
Cleanout/Monument Boxes;	Steel Riser Rings;
Construction Covers and Frames;	Trash receptacles;
Curb and Corner Guards;	Tree Grates;
Curb Openings;	Tree Guards;
Detectable Warning Plates;	Trench Grates; and
Downspout Shoes (Boot, Inlet);	Valve Boxes, Covers and Risers.

For AIS, structural steel is rolled flanged shapes, having at least one dimension of their cross-section three inches or greater, which are used in the construction of bridges, buildings, ships, railroad rolling stock, and for numerous other constructional purposes. Such shapes are designated as wide-flange shapes, standard I-beams, channels, angles, tees and zeeks. Other shapes include H-piles, sheet piling, tie plates, cross ties, and those for other special purposes.

For AIS, construction materials are those articles, materials, or supplies made primarily of iron and steel, that are permanently incorporated into the project, not including mechanical and/or electrical components, equipment and systems. Some of these products may overlap with what is also considered “structural steel.” This includes, but is not limited to, the following products: wire rod, bar, angles, concrete reinforcing bar, wire, wire cloth, wire rope and cables, tubing, framing, joists, trusses, fasteners (i.e., nuts and bolts), welding rods, decking, grating, railings, stairs, access ramps, fire escapes, ladders, wall panels, dome structures, roofing, ductwork, surface drains, cable handing systems, manhole steps, fencing and fence tubing, guardrails, doors, and stationary screens.

For the purposes of AIS, mechanical and electrical components, equipment and systems are not considered construction materials. Mechanical equipment is typically that which has motorized parts and/or is powered by a motor. Electrical equipment is typically any machine powered by electricity and includes components that are part of the electrical distribution system.

There are specific requirements for precast concrete to comply with AIS. While reinforced precast concrete may not be at least 50% iron or steel, in this case, the reinforcing bar and wire must be produced in the US and meet the same standards as for any other iron or steel product. Additionally, the casting of the concrete product must take place in the US. The cement and other raw materials used in concrete production are not required to be of domestic origin. If the reinforced concrete is cast at the construction site, the reinforcing bar and wire are considered a construction material and must be produced in the US.

Recordkeeping for Iron and Steel Products: Documenting the Country of Origin for Iron and Steel Products for Loan Programs

Loan recipients with assistance from their general contractor must be able to verify that products used in their projects comply with the AIS requirements. USEPA recommends loan recipients use a “Step Certification” process to ensure that producers adhere to the AIS requirements. Step certification is a process under which each handler (supplier, fabricator, manufacturer, etc.) of the iron and steel products certifies that their step in the process was domestically performed. Each time a step in the manufacturing process takes place, the manufacturer delivers its work along with a certification of its origin. A certification can be quite simple as long as it includes the name of the manufacturer, the location of the manufacturing facility (not company headquarters), a description of the product or item being delivered, and a signature by a manufacturer’s responsible party. An example of this type of certification is attached.

Certification could be achieved by other methods such as requiring the final manufacturer, who delivers the iron/steel products to the worksite, to provide certification that all manufacturing processes occurred in the US. While this type of certification is easier and acceptable, it may not provide the same degree of assurance and additional documentation may be needed. USEPA auditors recommend keeping records of when and where the products were delivered. Examples include: Perry Water Plant on August 3, 2017, or Jankousky Construction Offices on October 5, 2017. Records from the manufacturer should refer to specific items such as pipes, valves, meters. Try to avoid records containing broad statements such as, “All products delivered were made in the USA.”

Regardless of the method, documents regarding the country of origin for iron and steel products should be collected and maintained by all loan recipients. Having a good paper trail is invaluable during an inspection or audit.

Information is available at <http://www.epa.illinois.gov/topics/grants-loans/water-financial-assistance/state-revolving-fund/guidance/index>.

Sample Certification Letter

The following information is provided as a sample letter of step certification for AIS compliance. The completed letter is provided to the construction contractor or loan applicant from the supplier, fabricator, manufacturer, etc. of iron and steel products. Documentation must be provided on company letterhead. If e-mail is used, documents should be scanned so the company letterhead is visible.

Company Letterhead

Date

Company Name
Company Address
City, State, Zip

Subject: American Iron and Steel Step Certification for Project (xxx ***Identify Project Here*** xxx)

I, (company representative), certify that the (melting, bending, coating, galvanizing, cutting, etc.) process for (manufacturing or fabricating) the following products and/or materials shipped or provided for the subject project is in full compliance with the American Iron and Steel requirements as mandated in EPA's State Revolving Fund Programs.

Item, Products, and/or Materials:

1. XXX
2. XXX
3. XXX

Such process took place at the following location (City and State must be included):

If any of the above compliance statements change while providing material to the project we will immediately notify the prime contractor and the engineer.

Signed by Company Representative

**Local Public Agency
Proposal Bid Bond**

Local Public Agency County Section Number

WE, _____ as PRINCIPAL, and _____ as SURETY, are held jointly, severally and firmly bound unto the above Local Public Agency (hereafter referred to as "LPA") in the penal sum of 5% of the total bid price, or for the amount specified in the proposal documents in effect on the date of invitation for bids, whichever is the lesser sum. We bind ourselves, our heirs, executors, administrators, successors, and assigns, jointly pay to the LPA this sum under the conditions of this instrument.

WHEREAS THE CONDITION OF THE FOREGOING OBLIGATION IS SUCH that, the said PRINCIPAL is submitting a written proposal to the LPA acting through its awarding authority for the construction of the work designated as the above section.

THEREFORE if the proposal is accepted and a contract awarded to the PRINCIPAL by the LPA for the above designated section and the PRINCIPAL shall within fifteen (15) days after award enter into a formal contract, furnish surety guaranteeing the faithful performance of the work, and furnish evidence of the required insurance coverage, all as provided in the "Standard Specifications for Road and Bridge Construction" and applicable Supplemental Specifications, then this obligation shall become void; otherwise it shall remain in full force and effect.

IN THE EVENT the LPA determines the PRINCIPAL has failed to enter into a formal contract in compliance with any requirements set forth in the preceding paragraph, then the LPA acting through its awarding authority shall immediately be entitled to recover the full penal sum set out above, together with all court costs, all attorney fees, and any other expense of recovery.

IN TESTIMONY WHEREOF, the said PRINCIPAL and the said SURETY have caused this instrument to be signed by their respective officers this _____ of _____ Day Month and Year

Principal

Company Name

Company Name

Signature & Date
By:

Signature & Date
By:

Title

Title

(If Principal is a joint venture of two or more contractors, the company names, and authorized signatures of each contractor must be affixed.)

Surety

Name of Surety

Signature of Attorney-in-Fact Signature & Date
By:

STATE OF IL
COUNTY OF

I _____, a Notary Public in and for said county do hereby certify that

(Insert names of individuals signing on behalf of PRINCIPAL & SURETY)

who are each personally known to me to be the same persons whose names are subscribed to the foregoing instrument on behalf of PRINCIPAL and SURETY, appeared before me this day in person and acknowledged respectively, that they signed and delivered said instruments as their free and voluntary act for the uses and purposes therein set forth.

Given under my hand and notarial seal this _____ day of _____ Month and Year

(SEAL, if required by the LPA)

Notary Public Signature & Date

Date commission expires _____

Local Public Agency

County

Section Number

Village of Forest Park

Cook

ELECTRONIC BID BOND

Electronic bid bond is allowed (box must be checked by LPA if electronic bid bond is allowed)

The Principal may submit an electronic bid bond, in lieu of completing the above section of the Proposal Bid Bond Form. By providing an electronic bid bond ID code and signing below, the Principal is ensuring the identified electronic bid bond has been executed and the Principal and Surety are firmly bound unto the LPA under the conditions of the bid bond as shown above. (If PRINCIPAL is a joint venture of two or more contractors, an electronic bid bond ID code, company/Bidder name title and date must be affixed for each contractor in the venture.)

Electronic Bid Bond ID Code

--	--	--	--	--	--	--	--	--	--	--	--	--	--	--

Company/Bidder Name

--

Signature & Date

--

Title

--

Apprenticeship and Training Program Certification

Local Public Agency	County	Street Name/Road Name	Section Number
Village of Forest Park	Cook	Various Streets	

All contractors are required to complete the following certification

- For this contract proposal or for all bidding groups in this deliver and install proposal.
- For the following deliver and install bidding groups in this material proposal.

Illinois Department of Transportation policy, adopted in accordance with the provisions of the Illinois Highway Code, requires this contract to be awarded to the lowest responsive and responsible bidder. The award decision is subject to approval by the Department. In addition to all other responsibility factors, this contract or deliver and install proposal requires all bidders and all bidder's subcontractors to disclose participation in apprenticeship or training programs that are (1) approved by and registered with the United States Department of Labor's Bureau of Apprenticeship and Training, and (2) applicable to the work of the above indicated proposals or groups. Therefore, all bidders are required to complete the following certification:

1. Except as provided in paragraph 4 below, the undersigned bidder certifies that it is a participant, either as an individual or as part of a group program, in an approved apprenticeship or training program applicable to each type of work or craft that the bidder will perform with its own employees.
2. The undersigned bidder further certifies, for work to be performed by subcontract, that each of its subcontractors either (A) is, at the time of such bid, participating in an approved, applicable apprenticeship or training program; or (B) will, prior to commencement of performance of work pursuant to this contract, establish participation in an approved apprenticeship or training program applicable to the work of the subcontract.
3. The undersigned bidder, by inclusion in the list in the space below, certifies the official name of each program sponsor holding the Certificate of Registration for all of the types of work or crafts in which the bidder is a participant and that will be performed with the bidder's employees. Types of work or craft that will be subcontracted shall be included and listed as subcontract work. The list shall also indicate any type of work or craft job category for which there is no applicable apprenticeship or training program available.

4. Except for any work identified above, if any bidder or subcontractor shall perform all or part of the work of the contract or deliver and install proposal solely by individual owners, partners or members and not by employees to whom the payment of prevailing rates of wages would be required, check the following box, and identify the owner/operator workforces and positions of ownership.

The requirements of this certification and disclosure are a material part of the contract, and the contractor shall require this certification provision to be included in all approved subcontracts. The bidder is responsible for making a complete report and shall make certain that each type of work or craft job category that will be utilized on the project is accounted for and listed. The Department at any time before or afterward may require the production of a copy of each applicable Certificate of Registration issued by the United States Department of Labor evidencing such participation by the contractor and any or all of its subcontractors. In order to fulfill the participation requirement, it shall not be necessary that any applicable program sponsor be currently taking or that it will take applications for apprenticeship, training or employment during the performance of the work of this contract or deliver and install proposal.

Bidder	Signature & Date		
Title			
Address	City	State	Zip Code

TABLE OF CONTENTS

SPECIAL PROVISIONS..... 1
LOCATIONS OF IMPROVEMENT..... 1
DESCRIPTION OF IMPROVEMENT..... 1
WORKING DAYS..... 1
AVAILABILITY OF CONTRACT DOCUMENTS 1
AWARD OR REJECTION..... 2
CLEAN CONSTRUCTION DEBRIS DISPOSAL REQUIREMENTS..... 2
RESPONSIBLE BIDDER REQUIREMENTS 3
MAINTENANCE OF ROADWAYS..... 4
CONTRACTOR COORDINATION 4
VANDALISM..... 4
USE OF FIRE HYDRANTS..... 5
PUBLIC CONVENIENCE AND SAFETY 5
USE OF HEAVY EQUIPMENT, TOOLS; RESTRICTIONS 5
DUST CONTROL 6
MATERIAL TESTING/INSPECTION 6
BASE BID & ALTERNATE..... 7
WATER SERVICE ASBESTOS ABATEMENT 8
ITEMS ORDERED BY ENGINEER..... 9
VIDEOTAPING (INTERIOR AND EXTERIOR) 10
WATER SERVICE LINE (PRIVATE) – LEAD SERVICE REPLACEMENT, 1” 11
WATER SERVICE LINE (PRIVATE) – LEAD SERVICE REPLACEMENT, 1.5” 11
WATER SERVICE INTERIOR RESTORATION..... 14
STATUS OF UTILITIES (D-1) 15

Check Sheet for Recurring Special Provisions
Check Sheet for Local Roads and Streets Recurring Special Provisions
BDE Special Provision Check Sheet
Highway Standards

SPECIAL PROVISIONS

The following Special Provisions supplement the "Standard Specifications for Road and Bridge Construction", adopted January 1, 2022 (hereinafter referred to as the "Standard Specifications"); the "Supplemental Specifications and Recurring Special Provisions" adopted January 1, 2024 indicated on the index included herein; the latest edition of the "Illinois Manual on Uniform Traffic Control Devices for Streets and Highways" in effect on the date of invitation for bids; the "Standard Specifications for Water and Sewer Construction in Illinois" 2020 7th Edition; the "manual of Test Procedures of Materials" in effect on the date of invitation of bids, all of which apply to and govern the construction of the **Forest Park Lead Service Replacement Project – Phase 1** for the Village of Forest Park, Illinois, and in case of conflict with any part, or parts, of said specifications, the said special provisions shall take precedence and shall govern. Please note that the procurement is subject to regulations on

LOCATIONS OF IMPROVEMENT

Location Map and list of addresses is attached under Tab 1.

DESCRIPTION OF IMPROVEMENT

The proposed work is officially known as "Forest Park Lead Service Replacement Project – Phase 1". The work to be performed consists of water service installations including replacement of lead water service lines with either 1" or 1.5" copper water service lines from the Buffalo Box to 18-inches into the home of each address within the project limits. This water service replacement also includes any asbestos abatement, as well as any interior building restoration and collateral work necessary to complete the improvements as shown and described herein.

The contractor will submit two (2) schedules of prices. One for the private water services within the Base Bid limits as delineated on the map included in this booklet and a second for the private water services in the Base Bid + Alternate 1 limits as delineated on the map.

WORKING DAYS

The Contractor shall complete the work prior to May 1st, 2025.

AVAILABILITY OF CONTRACT DOCUMENTS

The Bidding Documents can be downloaded from QuestCDN via the Christopher B. Burke Engineering Ltd. (CBBEL) website <http://cbbel.com/bidding-info/> or at www.questcdn.com under Login using QuestCDN #9027851 for a non-refundable charge of \$50.00. A QuestCDN login will be required. Contact QuestCDN.com at 952-233-1632 or info@questcdn.com for assistance in membership registration and downloading this digital project information. Contractors must purchase bid documents and be shown on the Bidder's Placeholder List in

order to bid. Bids received from contractors who are not in the Bidder's Planholder List will be rejected.

Contractors must purchase bid documents and be shown on the Bidder's Planholder List in order to bid. Bids received from contractors who are not in the Bidder's Planholder List will be rejected.

DBE ADVERTISEMENT

Please note that in accordance with Illinois Environmental Protection Agency (IEPA) requirements, each bidder is required to advertise for sixteen (16) days minimum in either a *daily* newspaper or online clearinghouse such as Dodge or Quest in order to be eligible to be awarded the project.

AWARD OR REJECTION

The bidding requirements and conditions for contract award or rejection will follow IDOT-Bureau of Local Roads and Check Sheet # 6, contained herein, with the following additions:

"The Village reserves the right to reduce the scope of work based upon Village budget constraints, without penalty or additional compensation to the contractor."

CLEAN CONSTRUCTION DEBRIS DISPOSAL REQUIREMENTS

All Removal or Excavation items being disposed of at an uncontaminated soil fill operation or Clean Construction and Demolition Debris (CCDD) fill site shall meet the requirements of Public Act 96-1416. All costs associated with meeting these requirements shall be included in the unit price costs for the associated Removal or Excavation items in the Contract. These costs shall include but are not limited to all required testing, lab analysis, certification by a licensed Professional Engineer, and State and Local tipping fees.

RESPONSIBLE BIDDER REQUIREMENTS

The Village of Forest Park has responsible bidder requirements per the Village Code. Bidders shall submit with their proposal the following documents:

- a. Documents evidencing compliance with all applicable laws and ordinances prerequisite to doing business in Illinois.
- b. A valid federal employer tax identification number, or, if an individual, a valid social security number.
- c. A statement of compliance with the equal opportunity employer provisions of Section 2000e of Chapter 21, Title 42 of the United States Code and Federal Executive Order Number 11246, as amended, by Executive Order 11375 (known as the Equal Opportunity Employer Provision).
- d. Certificates of insurance indicating minimum insurance coverages as set forth in a bid specification, including general liability workers' compensation, completed operations, automobile, hazardous occupations, and products liability.
- e. Evidence of a written sexual harassment policy in compliance with the provisions of the Illinois Human Rights Act.
- f. A statement of compliance with the provisions of the Illinois Prevailing Wage Act.
- g. Evidence of compliance with the Substance Abuse Prevention on Public Works Projects Act.
- h. Evidence of relevant experience that indicates the necessary capacity to perform the project and adequate references verifying the quality of work performed.
- i. For Village public works construction projects (construction of new Village facilities, renovation of existing Village facilities or Village road and/or utility construction projects) over fifty thousand dollars (\$50,000.00), evidence of participation in apprentice and training programs applicable to the work to be performed on the project which are approved by and registered with the United States Department of Labor Office of Apprenticeship and Training or are reasonably equivalent to such programs.
- j. For Village construction projects (construction of new Village facilities, renovation of existing facilities or Village road and/or utility construction projects), responsible bidders must demonstrate a good faith effort toward providing equal employment opportunities for persons to work as craftpersons, laborers, workers or mechanics consistent with the racial, ethnic and gender demographics of the labor force available in the Illinois Department of Employment Security Chicago-Naperville-Joliet Metropolitan Division which consists of Cook DeKalb, DuPage, Grundy, Kane, Kendall, McHenry and Will Counties.

MAINTENANCE OF ROADWAYS

Effective: September 30, 1985 Revised: November 1, 1996

Beginning on the date that work begins on this project, the Contractor shall assume responsibility for normal maintenance of all existing roadways within the limits of the improvement. This normal maintenance shall include all repair work deemed necessary by the Engineer, but shall not include snow removal operations. Traffic control and protection for maintenance of roadways will be provided by the Contractor as required by the Engineer.

CONTRACTOR COORDINATION

The Contractor may be required to mobilize multiple times in order to best coordinate with other trades working toward completion of the Project. The Contractor shall be prepared to mobilize within 5 working days of being directed to do so by the Engineer. Additional payments for mobilization will not be paid beyond what is approved in this contract.

Schedules pertaining to the locations of other Trade work in the same area of work as the Contractor will be distributed prior to commencing work. The Contractor is responsible for coordinating work with the Engineer and other contractor(s). The Contractor shall take all precautions to prevent disturbance or damage to completed work by other Trades. Any damage of work completed by other Trades as a result of work performed by the Contractor, shall be brought to the Engineer's attention immediately. The costs associated with repairing such damage will be the sole responsibility of the Contractor.

It is the responsibility of the Contractor to coordinate effectively with all residents & business owners so that consistent production is met throughout the duration of the contract. The Village expects the Contractor to schedule appointments in a manner that affects homeowners as minimally as possible.

No additional compensation will be allowed for any delays, inconvenience, or damage sustained by the Contractor due to interference from additional Trades working for the same project.

VANDALISM

Special attention is called to the Special Provision for "Inspection" as well as Article 107.30 of the "Standard Specifications". **Any defaced work shall be corrected or replaced by the Contractor at Contractor's sole expense prior to final payment.** The Village of Forest Park shall cooperate with the Contractor to minimize vandalism, but the Contractor shall be ultimately responsible to correct any damage. The Village will not be responsible for the security of the work site in this regard, other than normal patrolling and response to emergencies. The cost of additional security required to meet this provision shall be solely the Contractor's responsibility.

USE OF FIRE HYDRANTS

This item shall be in accordance with Article 107 of Standard Specifications, construction water must be obtained from a tank truck and **not** from municipal fire hydrants. Prior approval is required and arrangements for filling a tank truck shall be made with the Village of Forest Park Public Works Department, 7343 15th Street, Forest Park, IL 60130.

PUBLIC CONVENIENCE AND SAFETY

In addition to the requirements of Article 107.09 of the "Standard Specifications for Road and Bridge Construction", the Contractor shall maintain entrances and side roads along the proposed improvement; interference with traffic movements and inconvenience to owners of abutting property and public shall be kept to a minimum. Any delays or inconveniences caused the Contractor by complying with these requirements shall be considered as incidental to the contract, and no additional compensation will be allowed.

The Contractor is to plan his work so that there will be no open holes in the pavement and that all barricades will be removed from the pavement during non-work hours.

During all construction operations, the Contractor will be required to provide, erect, and maintain proper signage and barricades plus provide flagmen as necessary for safe traffic control.

The Contractor will not be allowed to close any street to through travel without the prior approval of the Engineer. The Contractor will be required to provide all warning signs, barricades, traffic cones, flagmen and other appurtenances as directed by the Village. This work will not be paid for separately but shall be considered as incidental to the Contract and no extra compensation will be allowed.

USE OF HEAVY EQUIPMENT, TOOLS; RESTRICTIONS

Except as provided in subsections B, C and D of this Section, no person or entity may use "heavy equipment" in residential areas except between seven o'clock (7:00) A.M. and six o'clock (6:00) P.M. Monday through Friday and between eight o'clock (8:00) A.M. and five o'clock (5:00) P.M. on Saturdays and Sundays; and in commercial areas except between six o'clock (6:00) A.M. and six o'clock (6:00) P.M. Monday through Friday and between six o'clock (6:00) A.M. and six o'clock (6:00) P.M. on Saturdays and Sundays; provided, however, that such equipment shall not be used at any time on Federal holidays. For purposes of this Section, "heavy equipment" shall mean bulldozers, jackhammers, pile drivers, power hammers, chain saws, graders, riveters, earth movers, tree and stump grinders, trenchers, cement mixers, tractors, power hoists or derricks, demolition balls, power shovels, trucks, and power equipment on wheels or traction chains, or other similar equipment, but shall not include garbage trucks which are governed by separate agreement within the Village.

- A. Other Tools: Tools other than heavy equipment may be used at any time within a fully enclosed structure; any use of such tools outside a fully enclosed structure shall be prohibited between the hours of eight o'clock (8:00) P.M. and eight o'clock (8:00) A.M., except as provided in subsections B, C and D of this Section.
- B. Emergencies: The limitations stated in this Section shall not apply in any situation which requires heavy equipment or other tools in emergencies to assist or avoid a problem related to health or to safety of persons or property, or to sewer, water, power, utility, or telephone interruptions.
- C. Work by Public Agencies: The limitations stated in this Section may be waived by the Board of Trustees by resolution for work undertaken by any public body or agency for the benefit of the public. The Board of Trustees may attach to any such waiver all conditions it deems necessary to protect the public health, safety, or welfare.
- D. Waiver: The limitations stated in this Section may be waived by the Village Manager in areas of the Village zoned for nonresidential uses pursuant to the Village zoning ordinance; provided, however, that no such waiver shall be granted unless the Village Manager finds that:
 - 1. The party seeking the waiver will suffer a unique or unusual hardship unless the waiver is granted; and
 - 2. The granting of a waiver will not cause a substantial or undue adverse impact upon adjacent property or upon the public health, safety, and welfare. The Village Manager may attach to such waiver all conditions he deems necessary to protect the public health, safety, or welfare.

DUST CONTROL

The Contractor shall take appropriate measures to always control dust along the entire project by means such as mechanical sweeper, water truck, or as directed by the Engineer. All concrete sawcutting shall utilize a "wet cutting method" and shall be thoroughly cleaned at the end of each working day. This work shall be included in the cost of the contract.

MATERIAL TESTING/INSPECTION

All Hot-Mix Asphalt and P.C. Concrete materials used on this project shall be tested and inspected in accordance with the Illinois Department of Transportation's QC/QA requirements.

Additionally, the contractor shall provide the ENGINEER with IDOT approval and the latest QC gradations for any aggregate delivered to site.

QA Testing: The CONTRACTOR shall provide, to Village's Representative, 24-hour advance notice of construction for inspection of all Hot-Mix Asphalt and concrete materials used on this project.

The CONTRACTOR is to submit a QC plan for HMA and concrete materials to the Village's Representative for approval prior to construction operations commencing. The Village's Representative will approve this plan.

QC reports for asphalt mixtures will be transmitted directly by the CONTRACTOR daily during production. The Village's Representative will review and retain the QC plant reports. This work will not be paid for separately but cost to perform work shall be included in the total bid price.

BASE BID & ALTERNATE

The VILLAGE will award the contract to the low, responsive, bidder. The low bidder will be determined based on the Base Bid amount only. Alternate bids will be considered after the low bidder has been determined.

WATER SERVICE ASBESTOS ABATEMENT

Description. This work consists of the testing for removal, and proper disposal of friable and non-friable asbestos that is encountered during lead service replacement work.

General. The Contractor shall notify the Engineer if they anticipate that asbestos may be encountered when completing the lead water service replacement work. The Contractor shall coordinate any necessary testing, removal, and disposal of asbestos with the Engineer. No work shall take place without the approval of the Engineer.

Requirements. This work shall be completed in accordance with the requirements of the U.S. Environmental Protection Agency (USEPA), the Illinois Environmental Protection Agency (IEPA), Illinois Department of Health (IDPH) and the Occupational Safety and Health Administration (OSHA).

Basis of Payment. The testing, removal and abatement of asbestos shall be paid in accordance with Article 109.04 of the Standard Specifications.

ITEMS ORDERED BY ENGINEER

An allowance has been set aside as part of this contract for items ordered by the engineer.

The Contractor will include in his bid a unit price of \$1.00 for ITEMS ORDERED BY ENGINEER. Only additional work, not covered by existing Pay Items, indicated on the Drawings or in the Project Specifications will be eligible for payment under the Allowance.

VIDEOTAPING (INTERIOR AND EXTERIOR)

Description. The Contractor shall prepare preconstruction and post-construction video documentation of all home interior and exterior features that will be affected by construction.

Video Requirements. Video camera recorders shall be HD format equipment. Preconstruction and post-construction video documentation shall consist of a series of high-resolution color audio-video tapes. All pertinent exterior features within the construction's zone of influence shall be shown in sufficient detail to document their preconstruction and post-construction condition. Features to be shown shall include but not be limited to pavements, curbs, driveways, sidewalks, landscape retaining walls, buildings, landscaping trees, shrubbery, fences, light posts, etc. View orientation shall be maintained by audio commentary on the audio track of each video to help explain what is being viewed. The Contractor will be held liable for any damages that are not shown on the pre-construction video.

For interior videotaping, the Contractor shall document all areas affected by the proposed work including existing foundation or slab cracks, or other existing damage. Video shall also be obtained following restoration of the building interior.

Deliverable. The Contractor shall provide two thumb drives each of the preconstruction and post-construction videos to the Engineer. Any video(s) that is/are deemed incomplete (or of poor quality) by the Engineer shall be corrected before payment for the work will be allowed.

Basis of Payment. This work shall be paid for at the contract LUMP SUM price for VIDEOTAPING (INTERIOR AND EXTERIOR). No progress payments for any work will be processed until the preconstruction and post-construction videotapes have been received and approved by the Engineer.

WATER SERVICE LINE (PRIVATE) – LEAD SERVICE REPLACEMENT, 1”
WATER SERVICE LINE (PRIVATE) – LEAD SERVICE REPLACEMENT, 1.5”

Description. This work shall consist of the replacement of lead water services with Type K copper water services.

General. Where existing lead services are encountered on private property, exterior private water services shall be completely replaced. For any property where an existing private lead water service is encountered, the service shall be replaced as follows:

- Where the water meter is located inside the house, the private service shall be replaced from the b-box to the existing shut-off valve or 18-inches inside of the house. If there is no shut-off valve, the Contractor shall install a valve that meets the requirements of the current Illinois Plumbing Code. Water meters shall not be replaced.
- Where the water meter is located outside the house, the lead service shall be replaced from the b-box past the meter and 18-inches inside of the house. The water meter shall not be replaced.

Construction Requirements. All work shall be performed in accordance with ANSI/AWWA Standard C810-17, Replacement and Flushing of Lead Service Lines and the Illinois Plumbing Code.

The Contractor shall install the water service pipe to the water meter by method of trenchless installation. The water service shall be one continuous length. The use of couplings, joints, etc. will not be allowed. If the Contractor plans on using the pipe pulling method, he/she shall have a horizontal directional drill on site in the event the pipe pulling method is unsuccessful. Upon approval of the Engineer, the Contractor may install the water service pipe in an open trench. If an open trench is utilized, the trench shall be backfilled with excavated material. The excavated material shall be compacted in 12-inch lifts to the satisfaction of the Engineer.

The water service material shall be 1-inch or 1.5-inch diameter Type K copper and shall match or be a larger size than existing. Compression type fittings with stainless steel inserts shall be used at each connection. Splicing of the water service pipe will not be permitted.

Coring of concrete floor slabs and foundation walls shall comply with the following:

Coring of Concrete Floor Slabs

For buildings without basements, the Contractor shall core drill the concrete floor slab to allow for penetration of the water service pipe. The use of breakers or concrete saws to cut through the floor slab will not be allowed. The Contractor shall exercise caution to prevent damage to the floor slab caused by the coring operation. After all work is completed, the cored hole shall

be completely sealed with hydraulic cement to prevent water infiltration. The hydraulic cement shall be a high-quality, engineer approved material.

Coring of Foundation Walls

For houses with basements, the service will be installed through the foundation/basement wall in lieu of the basement floor unless otherwise directed by the Engineer. The Contractor will be allowed to core drill through the basement wall as part of the same trenchless installation operation of the private service. If the Contractor is unable to perform this task, either by lack of satisfactory performance (as determined by the Village) or existing condition limitations, the service will be installed through the basement wall as follows:

An exterior pit shall be hand excavated. Hydro excavation will not be allowed. The Contractor shall core drill the existing foundation wall to allow for the penetration of the water service pipe. The Contractor shall wrap the water service pipe with electrical tape so that a minimum 4 inches of electrical tape is visible on either side of the foundation wall. Upon completion of all work, the exterior pit shall be backfilled with excavated material compacted in 12-inch lifts.

The interior and exterior of the cored hole shall be completely sealed with hydraulic cement to prevent water infiltration. The hydraulic cement shall be a high-quality, engineer approved material. If the cored hole is exposed on the outside of the building, a coating of roof cement shall be added to the exterior of the foundation wall and should completely coat the seams of the cored hole. The Contractor shall exercise caution to prevent damage to the foundation caused by the coring operation.

The existing water meter shall remain and shall not be removed. All material necessary to connect the new water service to the existing plumbing shall be provided and installed by the Contractor's licensed plumber. All interior water service pipe material shall be type "L" copper pipe; 1-inch diameter on the upstream side of the meter; ¾-inch size (or match existing) on the downstream side of the meter, as necessary. The Contractor is responsible for any modifications to the interior plumbing necessary to install the new water service.

The Contractor shall be responsible for removing and properly disposing of any debris generated by the work on the interior and exterior of the home and restoring the area around the water service, including any obsolete lead plumbing material generated by the internal plumbing work. If it is necessary to move fixtures to complete the work, they shall be placed in their original location after completion of the work.

If an existing sanitary service is within six (6) feet of the proposed water service, the Contractor shall be responsible for televising the sanitary service with a snake camera or similar, after the proposed water service is installed, to ensure it was not damaged during construction.

This work shall also include abandoning the exterior lead water service. The lead water service line shall be cut, capped, and abandoned in place.

Restoration. All landscape and hardscape removal and restoration shall be included in this item. This shall include, but not be limited to, removal and replacement of existing decks, sidewalks, patios, decorative landscaping, fences, sheds, grassed areas, walkways, trees, bushes, etc., required to install the private water service. No separate payment shall be allowed for these items and the Village's intent is to minimize private property impacts through the use of trenchless installations. All private property shall be restored to pre-construction conditions or better. All grassed areas shall be restored with a minimum of 4" of topsoil and sodding, unless otherwise directed by the Engineer.

The private water service layouts shown on the plans are approximate and provided to aid Contractors with bidding. If approved by the Engineer, the layouts may be adjusted to minimize conflicts with existing landscaping and hardscaping. The bid price for this item shall include the cost of all work to be done on private property for each private water service.

The public portion of the water service (i.e. portion located with the public ROW) shall be installed and paid for in accordance with the special provision for WATER SERVICE REPLACEMENT WITH NEW BUFFALO BOX, 1 OR 2", SHORT SIDE or WATER SERVICE REPLACEMENT WITH NEW BUFFALO BOX, 1 OR 2", LONG SIDE.

Method of Measurement and Basis of Payment. This work shall be paid for at the contract unit price per EACH for WATER SERVICE LINE (PRIVATE) – LEAD SERVICE REPLACEMENT at the size specified.

WATER SERVICE INTERIOR RESTORATION

Description. This work shall consist of the interior restoration of buildings to repair any damages caused by the lead water service replacement work.

General. Interior restoration shall include removal, disposal, and replacement of structural components of the flooring and/or walls as well as restoration of flooring materials, drywall, trim, paint, etc. The interior of each building shall be restored to preconstruction conditions or better. Contractor shall be responsible for documenting the pre-project condition of each building/residence. This work will be paid for separately as PRECONSTRUCTION VIDEO TAPING.

Method of Measurement and Basis of Payment. This work shall be measured and paid for at the contract unit price each for EACH building/residence as WATER SERVICE INTERIOR RESTORATION, which payment shall be full compensation for all labor, materials, and equipment necessary to completely restore the interior of buildings with interior lead service replacement work to preconstruction conditions or better as specified.

STATUS OF UTILITIES (D-1)

Effective: June 1, 2016
 Revised: January 1, 2020

Utility companies and/or municipal owners located within the construction limits of this project have provided the following information regarding their facilities and the proposed improvements. The tables below contain a description of specific conflicts to be resolved and/or facilities which will require some action on the part of the Department’s contractor to proceed with work. Each table entry includes an identification of the action necessary and, if applicable, the estimated duration required for the resolution.

UTILITIES TO BE ADJUSTED

Conflicts noted below have been identified by following the suggested staging plan included in the contract. The company has been notified of all conflicts and will be required to obtain the necessary permits to complete their work; in some instances, resolution will be a function of the construction staging. The responsible agency must relocate, or complete new installations as noted below; this work has been deemed necessary to be complete for the Department’s contractor to then work in the stage under which the item has been listed.

No conflicts to be resolved *(or if there are conflicts they are to be listed as noted above)*

UTILITIES TO BE WATCHED AND PROTECTED

The areas of concern noted below have been identified by following the suggested staging plan included for the contract. The information provided is not a comprehensive list of all remaining utilities, but those which during coordination were identified as ones which might require the Department’s contractor to take into consideration when making the determination of the means and methods that would be required to construct the proposed improvement. In some instances, the contractor will be responsible to notify the owner in advance of the work to take place so necessary staffing on the owner’s part can be secured.

The following contact information is what was used during the preparation of the plans as provided by the owner of the facility.

Agency/Company Responsible to Resolve Conflict	Name of contact	Phone	E-mail address
AT&T (Distribution)	Jamel McGinnis	(630) 573-5450	g11629@att.com
Comcast	Martha Gieras	(224) 229-5862	Martha_gieras@cable.comcast.com
ComEd – Grand	Leslie	(630) 576-	Leslie.Paschal@exeloncorp.com

Prairie Transmission	Paschal	7094	Leslie.Paschal@comed.com
ComEd – Electronic Plan Submittal	Lisa Argast	(630) 576-7094	PlanSubmittalsandMapRequests@exeloncorp.com Lisa.argast@comed.com
Dupage County Water Commission	Ken Niles	(630) 516-1932	niles@dpwc.org
Metropolitan Water Reclamation District	Joseph Schuessler	(312) 751-3236	Joseph.Schuessler@mwr.org
Nicor Gas	Sakibul Forah	(630) 388-2903	gasmaps@southernco.com sforah@southernco.com

The above represents the best information available to the Department and is included for the convenience of the bidder. The days required for conflict resolution should be considered in the bid as this information has also been factored into the timeline identified for the project when setting the completion date. The applicable portions of the Standard Specifications for Road and Bridge Construction shall apply.

Estimated duration of time provided above for the first conflicts identified will begin on the date of the executed contract regardless of the status of the utility relocations. The responsible agencies will be working toward resolving subsequent conflicts in conjunction with contractor activities in the number of days noted.

The estimated relocation duration must be part of the progress schedule submitted by the contractor. A utility kickoff meeting will be scheduled between the Department, the Department’s contractor, and the utility companies when necessary. The Department’s contractor is responsible for contacting J.U.L.I.E. prior to all excavation work.

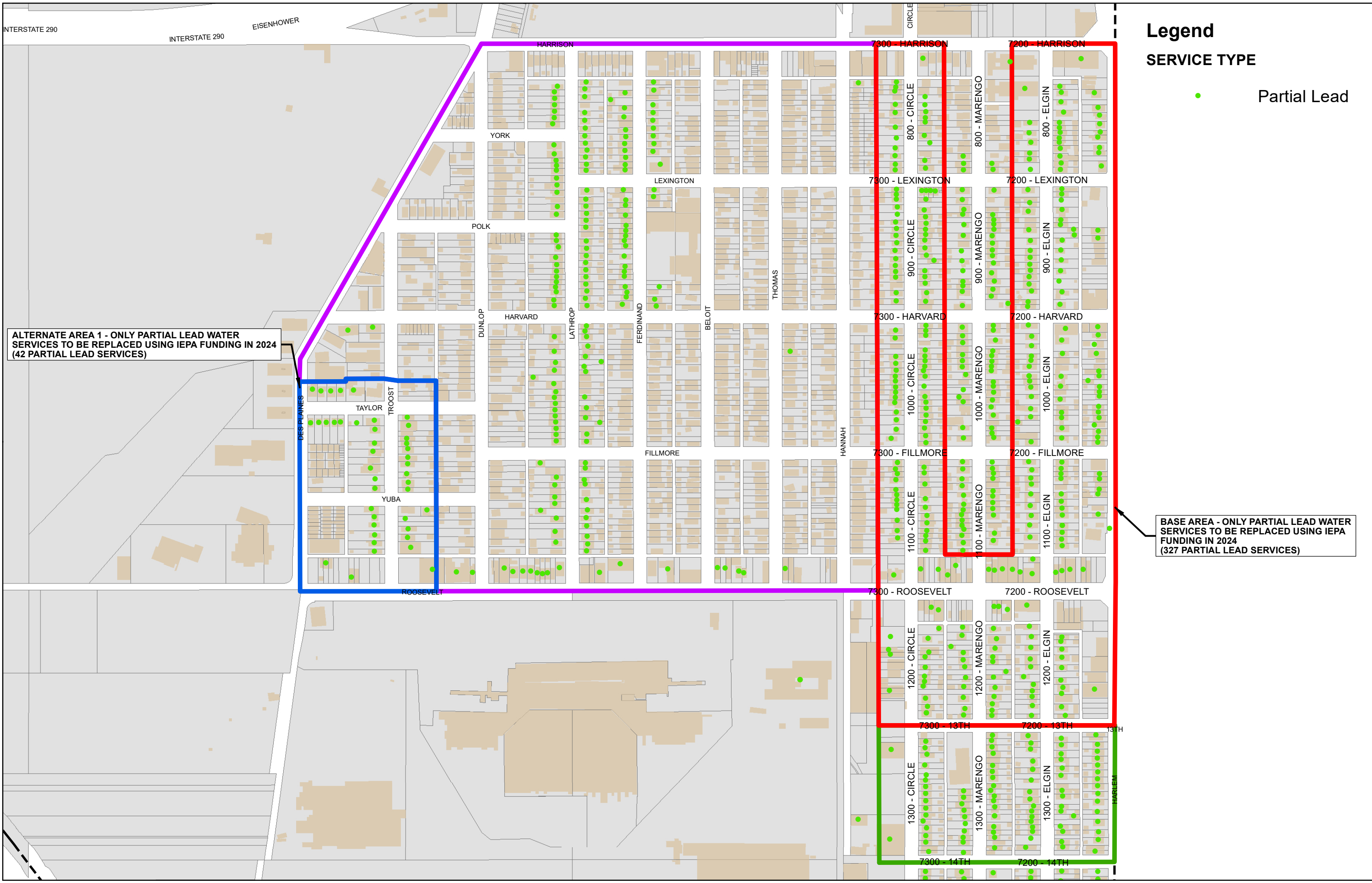

Legend
SERVICE TYPE
 ● Partial Lead

ALTERNATE AREA 1 - ONLY PARTIAL LEAD WATER SERVICES TO BE REPLACED USING IEPA FUNDING IN 2024 (42 PARTIAL LEAD SERVICES)

BASE AREA - ONLY PARTIAL LEAD WATER SERVICES TO BE REPLACED USING IEPA FUNDING IN 2024 (327 PARTIAL LEAD SERVICES)

BASE BID

NUMBER	ADDRESS	SERVICE TYPE
1	1001 Harlem Ave, Forest Park, Illinois, 60130	Partial Lead
2	1005 Harlem Ave, Forest Park, Illinois, 60130	Partial Lead
3	1009 Harlem Ave, Forest Park, Illinois, 60130	Partial Lead
4	1013 Harlem Ave, Forest Park, Illinois, 60130	Partial Lead
5	1019 Harlem Ave, Forest Park, Illinois, 60130	Partial Lead
6	1021 Harlem Ave, Forest Park, Illinois, 60130	Partial Lead
7	1023 Harlem Ave, Forest Park, Illinois, 60130	Partial Lead
8	1025 Harlem Ave, Forest Park, Illinois, 60130	Partial Lead
9	7201 Lexington St, Forest Park, Illinois, 60130	Partial Lead
10	1027 Harlem Ave, Forest Park, Illinois, 60130	Partial Lead
11	1029 Harlem Ave, Forest Park, Illinois, 60130	Partial Lead
12	1033 Harlem Ave, Forest Park, Illinois, 60130	Partial Lead
13	1035 Harlem Ave, Forest Park, Illinois, 60130	Partial Lead
14	1037 Harlem Ave, Forest Park, Illinois, 60130	Partial Lead
15	1039 Harlem Ave, Forest Park, Illinois, 60130	Partial Lead
16	1041 Harlem Ave, Forest Park, Illinois, 60130	Partial Lead
17	1045 Harlem Ave, Forest Park, Illinois, 60130	Partial Lead
18	1047 Harlem Ave, Forest Park, Illinois, 60130	Partial Lead
19	1105 Harlem Ave, Forest Park, Illinois, 60130	Partial Lead
20	1107 Harlem Ave, Forest Park, Illinois, 60130	Partial Lead
21	1111 Harlem Ave, Forest Park, Illinois, 60130	Partial Lead
22	1113 Harlem Ave, Forest Park, Illinois, 60130	Partial Lead
23	1121 Harlem Ave, Forest Park, Illinois, 60130	Partial Lead
24	1135 Harlem Ave, Forest Park, Illinois, 60130	Partial Lead
25	1229 Harlem Ave, Forest Park, Illinois, 60130	Partial Lead
26	7209 Roosevelt Rd, Forest Park, Illinois, 60130	Partial Lead
27	7213 Roosevelt Rd, Forest Park, Illinois, 60130	Partial Lead
28	7217 Roosevelt Rd, Forest Park, Illinois, 60130	Partial Lead
29	7221 Roosevelt Rd, Forest Park, Illinois, 60130	Partial Lead
30	815 Elgin Ave, Forest Park, Illinois, 60130	Partial Lead
31	814 Elgin Ave, Forest Park, Illinois, 60130	Partial Lead
32	816 Elgin Ave, Forest Park, Illinois, 60130	Partial Lead
33	820 Elgin Ave, Forest Park, Illinois, 60130	Partial Lead
34	824 Elgin Ave, Forest Park, Illinois, 60130	Partial Lead
35	828 Elgin Ave, Forest Park, Illinois, 60130	Partial Lead
36	829 Elgin Ave, Forest Park, Illinois, 60130	Partial Lead
37	830 Elgin Ave, Forest Park, Illinois, 60130	Partial Lead
38	832 Elgin Ave, Forest Park, Illinois, 60130	Partial Lead
39	833 Elgin Ave, Forest Park, Illinois, 60130	Partial Lead
40	834 Elgin Ave, Forest Park, Illinois, 60130	Partial Lead
41	836 Elgin Ave, Forest Park, Illinois, 60130	Partial Lead
42	837 Elgin Ave, Forest Park, Illinois, 60130	Partial Lead
43	838 Elgin Ave, Forest Park, Illinois, 60130	Partial Lead
44	841 Elgin Ave, Forest Park, Illinois, 60130	Partial Lead
45	842 Elgin Ave, Forest Park, Illinois, 60130	Partial Lead

BASE BID

NUMBER	ADDRESS	SERVICE TYPE
46	843 Elgin Ave, Forest Park, Illinois, 60130	Partial Lead
47	844 Elgin Ave, Forest Park, Illinois, 60130	Partial Lead
48	846 Elgin Ave, Forest Park, Illinois, 60130	Partial Lead
49	847 Elgin Ave, Forest Park, Illinois, 60130	Partial Lead
50	900 Elgin Ave, Forest Park, Illinois, 60130	Partial Lead
51	901 Elgin Ave, Forest Park, Illinois, 60130	Partial Lead
52	902 Elgin Ave, Forest Park, Illinois, 60130	Partial Lead
53	904 Elgin Ave, Forest Park, Illinois, 60130	Partial Lead
54	905 Elgin Ave, Forest Park, Illinois, 60130	Partial Lead
55	909 Elgin Ave, Forest Park, Illinois, 60130	Partial Lead
56	910 Elgin Ave, Forest Park, Illinois, 60130	Partial Lead
57	912 Elgin Ave, Forest Park, Illinois, 60130	Partial Lead
58	914 Elgin Ave, Forest Park, Illinois, 60130	Partial Lead
59	916 Elgin Ave, Forest Park, Illinois, 60130	Partial Lead
60	917 Elgin Ave, Forest Park, Illinois, 60130	Partial Lead
61	918 Elgin Ave, Forest Park, Illinois, 60130	Partial Lead
62	920 Elgin Ave, Forest Park, Illinois, 60130	Partial Lead
63	921 Elgin Ave, Forest Park, Illinois, 60130	Partial Lead
64	924 Elgin Ave, Forest Park, Illinois, 60130	Partial Lead
65	925 Elgin Ave, Forest Park, Illinois, 60130	Partial Lead
66	928 Elgin Ave, Forest Park, Illinois, 60130	Partial Lead
67	929 Elgin Ave, Forest Park, Illinois, 60130	Partial Lead
68	931 Elgin Ave, Forest Park, Illinois, 60130	Partial Lead
69	932 Elgin Ave, Forest Park, Illinois, 60130	Partial Lead
70	933 Elgin Ave, Forest Park, Illinois, 60130	Partial Lead
71	935 Elgin Ave, Forest Park, Illinois, 60130	Partial Lead
72	936 Elgin Ave, Forest Park, Illinois, 60130	Partial Lead
73	939 Elgin Ave, Forest Park, Illinois, 60130	Partial Lead
74	940 Elgin Ave, Forest Park, Illinois, 60130	Partial Lead
75	941 Elgin Ave, Forest Park, Illinois, 60130	Partial Lead
76	945 Elgin Ave, Forest Park, Illinois, 60130	Partial Lead
77	946 Elgin Ave, Forest Park, Illinois, 60130	Partial Lead
78	947 Elgin Ave, Forest Park, Illinois, 60130	Partial Lead
79	1000 Elgin Ave, Forest Park, Illinois, 60130	Partial Lead
80	1001 Elgin Ave, Forest Park, Illinois, 60130	Partial Lead
81	1005 Elgin Ave, Forest Park, Illinois, 60130	Partial Lead
82	1006 Elgin Ave, Forest Park, Illinois, 60130	Partial Lead
83	1009 Elgin Ave, Forest Park, Illinois, 60130	Partial Lead
84	1012 Elgin Ave, Forest Park, Illinois, 60130	Partial Lead
85	1013 Elgin Ave, Forest Park, Illinois, 60130	Partial Lead
86	1015 Elgin Ave, Forest Park, Illinois, 60130	Partial Lead
87	1017 Elgin Ave, Forest Park, Illinois, 60130	Partial Lead
88	1020 Elgin Ave, Forest Park, Illinois, 60130	Partial Lead
89	1021 Elgin Ave, Forest Park, Illinois, 60130	Partial Lead
90	1021 Elgin Ave, Forest Park, Illinois, 60130	Partial Lead

BASE BID

NUMBER	ADDRESS	SERVICE TYPE
91	1023 Elgin Ave, Forest Park, Illinois, 60130	Partial Lead
92	1024 Elgin Ave, Forest Park, Illinois, 60130	Partial Lead
93	1027 Elgin Ave, Forest Park, Illinois, 60130	Partial Lead
94	1028 Elgin Ave, Forest Park, Illinois, 60130	Partial Lead
95	1031 Elgin Ave, Forest Park, Illinois, 60130	Partial Lead
96	1034 Elgin Ave, Forest Park, Illinois, 60130	Partial Lead
97	1035 Elgin Ave, Forest Park, Illinois, 60130	Partial Lead
98	1036 Elgin Ave, Forest Park, Illinois, 60130	Partial Lead
99	1037 Elgin Ave, Forest Park, Illinois, 60130	Partial Lead
100	1039 Elgin Ave, Forest Park, Illinois, 60130	Partial Lead
101	1040 Elgin Ave, Forest Park, Illinois, 60130	Partial Lead
102	1044 Elgin Ave, Forest Park, Illinois, 60130	Partial Lead
103	1047 Elgin Ave, Forest Park, Illinois, 60130	Partial Lead
104	1100 Elgin Ave, Forest Park, Illinois, 60130	Partial Lead
105	1101 Elgin Ave, Forest Park, Illinois, 60130	Partial Lead
106	1102 Elgin Ave, Forest Park, Illinois, 60130	Partial Lead
107	1104 Elgin Ave, Forest Park, Illinois, 60130	Partial Lead
108	1105 Elgin Ave, Forest Park, Illinois, 60130	Partial Lead
109	1106 Elgin Ave, Forest Park, Illinois, 60130	Partial Lead
110	1107 Elgin Ave, Forest Park, Illinois, 60130	Partial Lead
111	1109 Elgin Ave, Forest Park, Illinois, 60130	Partial Lead
112	1112 Elgin Ave, Forest Park, Illinois, 60130	Partial Lead
113	1113 Elgin Ave, Forest Park, Illinois, 60130	Partial Lead
114	1114 Elgin Ave, Forest Park, Illinois, 60130	Partial Lead
115	1116 Elgin Ave, Forest Park, Illinois, 60130	Partial Lead
116	1117 Elgin Ave, Forest Park, Illinois, 60130	Partial Lead
117	1120 Elgin Ave, Forest Park, Illinois, 60130	Partial Lead
118	1121 Elgin Ave, Forest Park, Illinois, 60130	Partial Lead
119	1126 Elgin Ave, Forest Park, Illinois, 60130	Partial Lead
120	1126 Elgin Ave, Forest Park, Illinois, 60130	Partial Lead
121	1127 Elgin Ave, Forest Park, Illinois, 60130	Partial Lead
122	1128 Elgin Ave, Forest Park, Illinois, 60130	Partial Lead
123	1129 Elgin Ave, Forest Park, Illinois, 60130	Partial Lead
124	1130 Elgin Ave, Forest Park, Illinois, 60130	Partial Lead
125	1132 Elgin Ave, Forest Park, Illinois, 60130	Partial Lead
126	1137 Elgin Ave, Forest Park, Illinois, 60130	Partial Lead
127	7226 Roosevelt Rd, Forest Park, Illinois, 60130	Partial Lead
128	7235 Roosevelt Rd, Forest Park, Illinois, 60130	Partial Lead
129	7239 Roosevelt Rd, Forest Park, Illinois, 60130	Partial Lead
130	7240 Roosevelt Rd, Forest Park, Illinois, 60130	Partial Lead
131	7242 Roosevelt Rd, Forest Park, Illinois, 60130	Partial Lead
132	7241 Roosevelt Rd, Forest Park, Illinois, 60130	Partial Lead
133	7244 Roosevelt Rd, Forest Park, Illinois, 60130	Partial Lead
134	7245 Roosevelt Rd, Forest Park, Illinois, 60130	Partial Lead
135	7247 Roosevelt Rd, Forest Park, Illinois, 60130	Partial Lead

BASE BID

NUMBER	ADDRESS	SERVICE TYPE
136	1209 Elgin Ave, Forest Park, Illinois, 60130	Partial Lead
137	1214 Elgin Ave, Forest Park, Illinois, 60130	Partial Lead
138	1216 Elgin Ave, Forest Park, Illinois, 60130	Partial Lead
139	1217 Elgin Ave, Forest Park, Illinois, 60130	Partial Lead
140	1220 Elgin Ave, Forest Park, Illinois, 60130	Partial Lead
141	1221 Elgin Ave, Forest Park, Illinois, 60130	Partial Lead
142	1225 Elgin Ave, Forest Park, Illinois, 60130	Partial Lead
143	1224 Elgin Ave, Forest Park, Illinois, 60130	Partial Lead
144	1227 Elgin Ave, Forest Park, Illinois, 60130	Partial Lead
145	1228 Elgin Ave, Forest Park, Illinois, 60130	Partial Lead
146	1231 Elgin Ave, Forest Park, Illinois, 60130	Partial Lead
147	1232 Elgin Ave, Forest Park, Illinois, 60130	Partial Lead
148	1234 Elgin Ave, Forest Park, Illinois, 60130	Partial Lead
149	1235 Elgin Ave, Forest Park, Illinois, 60130	Partial Lead
150	1237 Elgin Ave, Forest Park, Illinois, 60130	Partial Lead
151	1238 Elgin Ave, Forest Park, Illinois, 60130	Partial Lead
152	1239 Elgin Ave, Forest Park, Illinois, 60130	Partial Lead
153	1242 Elgin Ave, Forest Park, Illinois, 60130	Partial Lead
154	1243 Elgin Ave, Forest Park, Illinois, 60130	Partial Lead
155	1247 Elgin Ave, Forest Park, Illinois, 60130	Partial Lead
156	1246 Elgin Ave, Forest Park, Illinois, 60130	Partial Lead
157	1211 Marengo Ave, Forest Park, Illinois, 60130	Partial Lead
158	1212 Marengo Ave, Forest Park, Illinois, 60130	Partial Lead
159	1215 Marengo Ave, Forest Park, Illinois, 60130	Partial Lead
160	1216 Marengo Ave, Forest Park, Illinois, 60130	Partial Lead
161	1219 Marengo Ave, Forest Park, Illinois, 60130	Partial Lead
162	1220 Marengo Ave, Forest Park, Illinois, 60130	Partial Lead
163	1222 Marengo Ave, Forest Park, Illinois, 60130	Partial Lead
164	1223 Marengo Ave, Forest Park, Illinois, 60130	Partial Lead
165	1224 Marengo Ave, Forest Park, Illinois, 60130	Partial Lead
166	1225 Marengo Ave, Forest Park, Illinois, 60130	Partial Lead
167	1227 Marengo Ave, Forest Park, Illinois, 60130	Partial Lead
168	1228 Marengo Ave, Forest Park, Illinois, 60130	Partial Lead
169	1230 Marengo Ave, Forest Park, Illinois, 60130	Partial Lead
170	1233 Marengo Ave, Forest Park, Illinois, 60130	Partial Lead
171	1234 Marengo Ave, Forest Park, Illinois, 60130	Partial Lead
172	1235 Marengo Ave, Forest Park, Illinois, 60130	Partial Lead
173	1237 Marengo Ave, Forest Park, Illinois, 60130	Partial Lead
174	1238 Marengo Ave, Forest Park, Illinois, 60130	Partial Lead
175	1242 Marengo Ave, Forest Park, Illinois, 60130	Partial Lead
176	1244 Marengo Ave, Forest Park, Illinois, 60130	Partial Lead
177	1245 Marengo Ave, Forest Park, Illinois, 60130	Partial Lead
178	1246 Marengo Ave, Forest Park, Illinois, 60130	Partial Lead
179	1247 Marengo Ave, Forest Park, Illinois, 60130	Partial Lead
180	800 Circle Ave, Forest Park, Illinois, 60130	Partial Lead

NUMBER	BASE BID ADDRESS	SERVICE TYPE
181	813 Circle Ave, Forest Park, Illinois, 60130	Partial Lead
182	815 Circle Ave, Forest Park, Illinois, 60130	Partial Lead
183	817 Circle Ave, Forest Park, Illinois, 60130	Partial Lead
184	818 Circle Ave, Forest Park, Illinois, 60130	Partial Lead
185	821 Circle Ave, Forest Park, Illinois, 60130	Partial Lead
186	822 Circle Ave, Forest Park, Illinois, 60130	Partial Lead
187	824 Circle Ave, Forest Park, Illinois, 60130	Partial Lead
188	825 Circle Ave, Forest Park, Illinois, 60130	Partial Lead
189	826 Circle Ave, Forest Park, Illinois, 60130	Partial Lead
190	828 Circle Ave, Forest Park, Illinois, 60130	Partial Lead
191	831 Circle Ave, Forest Park, Illinois, 60130	Partial Lead
192	834 Circle Ave, Forest Park, Illinois, 60130	Partial Lead
193	835 Circle Ave, Forest Park, Illinois, 60130	Partial Lead
194	836 Circle Ave, Forest Park, Illinois, 60130	Partial Lead
195	839 Circle Ave, Forest Park, Illinois, 60130	Partial Lead
196	841 Circle Ave, Forest Park, Illinois, 60130	Partial Lead
197	843 Circle Ave, Forest Park, Illinois, 60130	Partial Lead
198	844 Circle Ave, Forest Park, Illinois, 60130	Partial Lead
199	845 Circle Ave, Forest Park, Illinois, 60130	Partial Lead
200	846 Circle Ave, Forest Park, Illinois, 60130	Partial Lead
201	7312 Lexington St, Forest Park, Illinois, 60130	Partial Lead
202	7314 Lexington St, Forest Park, Illinois, 60130	Partial Lead
203	7316 Lexington St, Forest Park, Illinois, 60130	Partial Lead
204	7318 Lexington St, Forest Park, Illinois, 60130	Partial Lead
205	901 Circle Ave, Forest Park, Illinois, 60130	Partial Lead
206	903 Circle Ave, Forest Park, Illinois, 60130	Partial Lead
207	904 Circle Ave, Forest Park, Illinois, 60130	Partial Lead
208	905 Circle Ave, Forest Park, Illinois, 60130	Partial Lead
209	909 Circle Ave, Forest Park, Illinois, 60130	Partial Lead
210	910 Circle Ave, Forest Park, Illinois, 60130	Partial Lead
211	911 Circle Ave, Forest Park, Illinois, 60130	Partial Lead
212	912 Circle Ave, Forest Park, Illinois, 60130	Partial Lead
213	914 Circle Ave, Forest Park, Illinois, 60130	Partial Lead
214	915 Circle Ave, Forest Park, Illinois, 60130	Partial Lead
215	916 Circle Ave, Forest Park, Illinois, 60130	Partial Lead
216	917 Circle Ave, Forest Park, Illinois, 60130	Partial Lead
217	918 Circle Ave, Forest Park, Illinois, 60130	Partial Lead
218	919 Circle Ave, Forest Park, Illinois, 60130	Partial Lead
219	920 Circle Ave, Forest Park, Illinois, 60130	Partial Lead
220	923 Circle Ave, Forest Park, Illinois, 60130	Partial Lead
221	924 Circle Ave, Forest Park, Illinois, 60130	Partial Lead
222	926 Circle Ave, Forest Park, Illinois, 60130	Partial Lead
223	927 Circle Ave, Forest Park, Illinois, 60130	Partial Lead
224	928 Circle Ave, Forest Park, Illinois, 60130	Partial Lead
225	929 Circle Ave, Forest Park, Illinois, 60130	Partial Lead

NUMBER	BASE BID ADDRESS	SERVICE TYPE
226	931 Circle Ave, Forest Park, Illinois, 60130	Partial Lead
227	932 Circle Ave, Forest Park, Illinois, 60130	Partial Lead
228	933 Circle Ave, Forest Park, Illinois, 60130	Partial Lead
229	934 Circle Ave, Forest Park, Illinois, 60130	Partial Lead
230	935 Circle Ave, Forest Park, Illinois, 60130	Partial Lead
231	938 Circle Ave, Forest Park, Illinois, 60130	Partial Lead
232	939 Circle Ave, Forest Park, Illinois, 60130	Partial Lead
233	940 Circle Ave, Forest Park, Illinois, 60130	Partial Lead
234	944 Circle Ave, Forest Park, Illinois, 60130	Partial Lead
235	945 Circle Ave, Forest Park, Illinois, 60130	Partial Lead
236	1000 Circle Ave, Forest Park, Illinois, 60130	Partial Lead
237	1002 Circle Ave, Forest Park, Illinois, 60130	Partial Lead
238	1003 Circle Ave, Forest Park, Illinois, 60130	Partial Lead
239	1004 Circle Ave, Forest Park, Illinois, 60130	Partial Lead
240	1005 Circle Ave, Forest Park, Illinois, 60130	Partial Lead
241	1010 Circle Ave, Forest Park, Illinois, 60130	Partial Lead
242	1012 Circle Ave, Forest Park, Illinois, 60130	Partial Lead
243	1013 Circle Ave, Forest Park, Illinois, 60130	Partial Lead
244	1014 Circle Ave, Forest Park, Illinois, 60130	Partial Lead
245	1016 Circle Ave, Forest Park, Illinois, 60130	Partial Lead
246	1017 Circle Ave, Forest Park, Illinois, 60130	Partial Lead
247	1018 Circle Ave, Forest Park, Illinois, 60130	Partial Lead
248	1019 Circle Ave, Forest Park, Illinois, 60130	Partial Lead
249	1020 Circle Ave, Forest Park, Illinois, 60130	Partial Lead
250	1021 Circle Ave, Forest Park, Illinois, 60130	Partial Lead
251	1023 Circle Ave, Forest Park, Illinois, 60130	Partial Lead
252	1024 Circle Ave, Forest Park, Illinois, 60130	Partial Lead
253	1025 Circle Ave, Forest Park, Illinois, 60130	Partial Lead
254	1027 Circle Ave, Forest Park, Illinois, 60130	Partial Lead
255	1028 Circle Ave, Forest Park, Illinois, 60130	Partial Lead
256	1029 Circle Ave, Forest Park, Illinois, 60130	Partial Lead
257	1030 Circle Ave, Forest Park, Illinois, 60130	Partial Lead
258	1032 Circle Ave, Forest Park, Illinois, 60130	Partial Lead
259	1033 Circle Ave, Forest Park, Illinois, 60130	Partial Lead
260	1034 Circle Ave, Forest Park, Illinois, 60130	Partial Lead
261	1035 Circle Ave, Forest Park, Illinois, 60130	Partial Lead
262	1036 Circle Ave, Forest Park, Illinois, 60130	Partial Lead
263	1039 Circle Ave, Forest Park, Illinois, 60130	Partial Lead
264	1040 Circle Ave, Forest Park, Illinois, 60130	Partial Lead
265	1041 Circle Ave, Forest Park, Illinois, 60130	Partial Lead
266	1042 Circle Ave, Forest Park, Illinois, 60130	Partial Lead
267	1046 Circle Ave, Forest Park, Illinois, 60130	Partial Lead
268	7333 Fillmore St, Forest Park, Illinois, 60130	Partial Lead
269	1101 Circle Ave, Forest Park, Illinois, 60130	Partial Lead
270	1102 Circle Ave, Forest Park, Illinois, 60130	Partial Lead

BASE BID

NUMBER	ADDRESS	SERVICE TYPE
271	1103 Circle Ave, Forest Park, Illinois, 60130	Partial Lead
272	1104 Circle Ave, Forest Park, Illinois, 60130	Partial Lead
273	1105 Circle Ave, Forest Park, Illinois, 60130	Partial Lead
274	1107 Circle Ave, Forest Park, Illinois, 60130	Partial Lead
275	1108 Circle Ave, Forest Park, Illinois, 60130	Partial Lead
276	1111 Circle Ave, Forest Park, Illinois, 60130	Partial Lead
277	1113 Circle Ave, Forest Park, Illinois, 60130	Partial Lead
278	1114 Circle Ave, Forest Park, Illinois, 60130	Partial Lead
279	1115 Circle Ave, Forest Park, Illinois, 60130	Partial Lead
280	1117 Circle Ave, Forest Park, Illinois, 60130	Partial Lead
281	1118 Circle Ave, Forest Park, Illinois, 60130	Partial Lead
282	1119 Circle Ave, Forest Park, Illinois, 60130	Partial Lead
283	1120 Circle Ave, Forest Park, Illinois, 60130	Partial Lead
284	1122 Circle Ave, Forest Park, Illinois, 60130	Partial Lead
285	1123 Circle Ave, Forest Park, Illinois, 60130	Partial Lead
286	1126 Circle Ave, Forest Park, Illinois, 60130	Partial Lead
287	1127 Circle Ave, Forest Park, Illinois, 60130	Partial Lead
288	1128 Circle Ave, Forest Park, Illinois, 60130	Partial Lead
289	1130 Circle Ave, Forest Park, Illinois, 60130	Partial Lead
290	1131 Circle Ave, Forest Park, Illinois, 60130	Partial Lead
291	1134 Circle Ave, Forest Park, Illinois, 60130	Partial Lead
292	7309 Roosevelt Rd, Forest Park, Illinois, 60130	Partial Lead
293	7310 Roosevelt Rd, Forest Park, Illinois, 60130	Partial Lead
294	7313 Roosevelt Rd, Forest Park, Illinois, 60130	Partial Lead
295	7316 Roosevelt Rd, Forest Park, Illinois, 60130	Partial Lead
296	7317 Roosevelt Rd, Forest Park, Illinois, 60130	Partial Lead
297	7331 Roosevelt Rd, Forest Park, Illinois, 60130	Partial Lead
298	1212 Circle Ave, Forest Park, Illinois, 60130	Partial Lead
299	1213 Circle Ave, Forest Park, Illinois, 60130	Partial Lead
300	1216 Circle Ave, Forest Park, Illinois, 60130	Partial Lead
301	1218 Circle Ave, Forest Park, Illinois, 60130	Partial Lead
302	1222 Circle Ave, Forest Park, Illinois, 60130	Partial Lead
303	1223 Circle Ave, Forest Park, Illinois, 60130	Partial Lead
304	1225 Circle Ave, Forest Park, Illinois, 60130	Partial Lead
305	1226 Circle Ave, Forest Park, Illinois, 60130	Partial Lead
306	1230 Circle Ave, Forest Park, Illinois, 60130	Partial Lead
307	1232 Circle Ave, Forest Park, Illinois, 60130	Partial Lead
308	1234 Circle Ave, Forest Park, Illinois, 60130	Partial Lead
309	1236 Circle Ave, Forest Park, Illinois, 60130	Partial Lead
310	1237 Circle Ave, Forest Park, Illinois, 60130	Partial Lead
311	1242 Circle Ave, Forest Park, Illinois, 60130	Partial Lead
312	1246 Circle Ave, Forest Park, Illinois, 60130	Partial Lead
313	7319 13th St, Forest Park, Illinois, 60130	Partial Lead
314	801 Harlem Ave, Forest Park, Illinois, 60130	Partial Lead
315	819 Harlem Ave, Forest Park, Illinois, 60130	Partial Lead

NUMBER	BASE BID ADDRESS	SERVICE TYPE
316	823 Harlem Ave, Forest Park, Illinois, 60130	Partial Lead
317	827 Harlem Ave, Forest Park, Illinois, 60130	Partial Lead
318	829 Harlem Ave, Forest Park, Illinois, 60130	Partial Lead
319	833 Harlem Ave, Forest Park, Illinois, 60130	Partial Lead
320	837 Harlem Ave, Forest Park, Illinois, 60130	Partial Lead
321	839 Harlem Ave, Forest Park, Illinois, 60130	Partial Lead
322	841 Harlem Ave, Forest Park, Illinois, 60130	Partial Lead
323	917 Harlem Ave, Forest Park, Illinois, 60130	Partial Lead
324	921 Harlem Ave, Forest Park, Illinois, 60130	Partial Lead
325	7242 Roosevelt Rd, Forest Park, Illinois, 60130	Partial Lead
326	7227 Roosevelt Rd, Forest Park, Illinois, 60130	Partial Lead
327	7307 Roosevelt Rd, Forest Park, Illinois, 60130	Partial Lead

NUMBER	ALTERNATE 1 ADDRESS	SERVICE TYPE
328	1036 Troost Ave, Forest Park, Illinois, 60130	Partial Lead
329	1038 Troost Ave, Forest Park, Illinois, 60130	Partial Lead
330	1039 Troost Ave, Forest Park, Illinois, 60130	Partial Lead
331	1044 Troost Ave, Forest Park, Illinois, 60130	Partial Lead
332	1045 Troost Ave, Forest Park, Illinois, 60130	Partial Lead
333	1046 Troost Ave, Forest Park, Illinois, 60130	Partial Lead
334	1047 Troost Ave, Forest Park, Illinois, 60130	Partial Lead
335	1048 Troost Ave, Forest Park, Illinois, 60130	Partial Lead
336	1050 Troost Ave, Forest Park, Illinois, 60130	Partial Lead
337	7720 Taylor St, Forest Park, Illinois, 60130	Partial Lead
338	7730 Taylor St, Forest Park, Illinois, 60130	Partial Lead
339	7733 Taylor St, Forest Park, Illinois, 60130	Partial Lead
340	7736 Taylor St, Forest Park, Illinois, 60130	Partial Lead
341	7737 Taylor St, Forest Park, Illinois, 60130	Partial Lead
342	7740 Taylor St, Forest Park, Illinois, 60130	Partial Lead
343	7741 Taylor St, Forest Park, Illinois, 60130	Partial Lead
344	7742 Taylor St, Forest Park, Illinois, 60130	Partial Lead
345	7744 Taylor St, Forest Park, Illinois, 60130	Partial Lead
346	7745 Taylor St, Forest Park, Illinois, 60130	Partial Lead
347	7747 Taylor St, Forest Park, Illinois, 60130	Partial Lead
348	7748 Taylor St, Forest Park, Illinois, 60130	Partial Lead
349	1100 Troost Ave, Forest Park, Illinois, 60130	Partial Lead
350	1103 Troost Ave, Forest Park, Illinois, 60130	Partial Lead
351	1104 Troost Ave, Forest Park, Illinois, 60130	Partial Lead
352	1106 Troost Ave, Forest Park, Illinois, 60130	Partial Lead
353	1109 Troost Ave, Forest Park, Illinois, 60130	Partial Lead
354	1110 Troost Ave, Forest Park, Illinois, 60130	Partial Lead
355	1111 Troost Ave, Forest Park, Illinois, 60130	Partial Lead
356	7700 Yuba St, Forest Park, Illinois, 60130	Partial Lead
357	1117 Troost Ave, Forest Park, Illinois, 60130	Partial Lead
358	1119 Troost Ave, Forest Park, Illinois, 60130	Partial Lead
359	1122 Troost Ave, Forest Park, Illinois, 60130	Partial Lead
360	1125 Troost Ave, Forest Park, Illinois, 60130	Partial Lead
361	1126 Troost Ave, Forest Park, Illinois, 60130	Partial Lead
362	1127 Troost Ave, Forest Park, Illinois, 60130	Partial Lead
363	1130 Troost Ave, Forest Park, Illinois, 60130	Partial Lead
364	1131 Troost Ave, Forest Park, Illinois, 60130	Partial Lead
365	1132 Troost Ave, Forest Park, Illinois, 60130	Partial Lead
366	1135 Troost Ave, Forest Park, Illinois, 60130	Partial Lead
367	7737 Roosevelt Rd, Forest Park, Illinois, 60130	Partial Lead
368	7749 Roosevelt Rd, Forest Park, Illinois, 60130	Partial Lead
369	7711 Roosevelt Rd, Forest Park, Illinois, 60130	Partial Lead



Check Sheet for Recurring Special Provisions

Local Public Agency	County	Section Number
Village of Forest Park	Cook	

Check this box for lettings prior to 01/01/2024.

The Following Recurring Special Provisions Indicated By An "X" Are Applicable To This Contract And Are Included By Reference:

Recurring Special Provisions

<u>Check Sheet #</u>		<u>Page No.</u>
1	<input type="checkbox"/> Additional State Requirements for Federal-Aid Construction Contracts	59
2	<input type="checkbox"/> Subletting of Contracts (Federal-Aid Contracts)	62
3	<input type="checkbox"/> EEO	63
4	<input type="checkbox"/> Specific EEO Responsibilities Non Federal-Aid Contracts	73
5	<input type="checkbox"/> Required Provisions - State Contracts	78
6	<input type="checkbox"/> Asbestos Bearing Pad Removal	84
7	<input type="checkbox"/> Asbestos Waterproofing Membrane and Asbestos HMA Surface Removal	85
8	<input type="checkbox"/> Temporary Stream Crossings and In-Stream Work Pads	86
9	<input checked="" type="checkbox"/> Construction Layout Stakes	87
10	<input type="checkbox"/> Use of Geotextile Fabric for Railroad Crossing	90
11	<input type="checkbox"/> Subsealing of Concrete Pavements	92
12	<input type="checkbox"/> Hot-Mix Asphalt Surface Correction	96
13	<input type="checkbox"/> Pavement and Shoulder Resurfacing	98
14	<input checked="" type="checkbox"/> Patching with Hot-Mix Asphalt Overlay Removal	99
15	<input type="checkbox"/> Polymer Concrete	101
16	<input type="checkbox"/> Reserved	103
17	<input type="checkbox"/> Bicycle Racks	104
18	<input type="checkbox"/> Temporary Portable Bridge Traffic Signals	106
19	<input type="checkbox"/> Nighttime Inspection of Roadway Lighting	108
20	<input type="checkbox"/> English Substitution of Metric Bolts	109
21	<input type="checkbox"/> Calcium Chloride Accelerator for Portland Cement Concrete	110
22	<input type="checkbox"/> Quality Control of Concrete Mixtures at the Plant	111
23	<input checked="" type="checkbox"/> Quality Control/Quality Assurance of Concrete Mixtures	119
24	<input type="checkbox"/> Reserved	135
25	<input type="checkbox"/> Reserved	136
26	<input type="checkbox"/> Temporary Raised Pavement Markers	137
27	<input type="checkbox"/> Restoring Bridge Approach Pavements Using High-Density Foam	138
28	<input type="checkbox"/> Portland Cement Concrete Inlay or Overlay	141
29	<input type="checkbox"/> Portland Cement Concrete Partial Depth Hot-Mix Asphalt Patching	145
30	<input type="checkbox"/> Longitudinal Joint and Crack Patching	148
31	<input type="checkbox"/> Concrete Mix Design - Department Provided	150
32	<input type="checkbox"/> Station Numbers in Pavements or Overlays	151

Local Public Agency

County

Section Number

Village of Forest Park

Cook

The Following Local Roads And Streets Recurring Special Provisions Indicated By An "X" Are Applicable To This Contract And Are Included By Reference:

Local Roads And Streets Recurring Special Provisions

<u>Check Sheet #</u>		<u>Page No.</u>
LRS 1	Reserved	153
LRS 2	<input type="checkbox"/> Furnished Excavation	154
LRS 3	<input checked="" type="checkbox"/> Work Zone Traffic Control Surveillance	155
LRS 4	<input checked="" type="checkbox"/> Flaggers in Work Zones	156
LRS 5	<input checked="" type="checkbox"/> Contract Claims	157
LRS 6	<input checked="" type="checkbox"/> Bidding Requirements and Conditions for Contract Proposals	158
LRS 7	<input type="checkbox"/> Bidding Requirements and Conditions for Material Proposals	164
LRS 8	Reserved	170
LRS 9	<input type="checkbox"/> Bituminous Surface Treatments	171
LRS 10	Reserved	175
LRS 11	<input checked="" type="checkbox"/> Employment Practices	176
LRS 12	<input checked="" type="checkbox"/> Wages of Employees on Public Works	178
LRS 13	<input checked="" type="checkbox"/> Selection of Labor	180
LRS 14	<input type="checkbox"/> Paving Brick and Concrete Paver Pavements and Sidewalks	181
LRS 15	<input checked="" type="checkbox"/> Partial Payments	184
LRS 16	<input type="checkbox"/> Protests on Local Lettings	185
LRS 17	<input checked="" type="checkbox"/> Substance Abuse Prevention Program	186
LRS 18	<input type="checkbox"/> Multigrade Cold Mix Asphalt	187
LRS 19	<input type="checkbox"/> Reflective Crack Control Treatment	188

Instructions for BLR 11300 - Page 1 of 1

Note: Instructions are not to be submitted with the form.

This form shall be used and included in proposal/contract documents. Items checked on the check sheet are included by reference and do not need to also be attached.

For more information see Chapter 11 of the Bureau of Local Roads and Street Manual (BLRS Manual).

Local Public Agency	Insert the name of the Local Public Agency (LPA) the proposal is for.
County	From the drop down, select the name of the County in which the LPA is located.
Section Number	Insert the section number without dashes that the proposal/contract is for.
Check Box for Letting Date	Check this box if the letting is to be held prior to January 1, 2024. For lettings held on or after January 1, 2024 leave the box blank. This choice allows the correct version of the form to display for the desired letting.
Special Provisions	Check the boxes for the Recurring Special Provisions and the Local Roads and Streets Recurring Special Provisions which are to be included in this proposal/contract package by reference.

This form is to be submitted in the proposal packet for material proposal/deliver and install proposals and contract proposals.

BDE SPECIAL PROVISIONS
For the January 19 and March 8, 2024 Lettings

The following special provisions indicated by a “check mark” are applicable to this contract and will be included by the Project Coordination and Implementation Section of the Bureau of Design & Environment (BDE).

File Name	#		Special Provision Title	Effective	Revised
	80099	1	<input type="checkbox"/> Accessible Pedestrian Signals (APS)	April 1, 2003	Jan. 1, 2022
	80274	2	<input type="checkbox"/> Aggregate Subgrade Improvement	April 1, 2012	April 1, 2022
	80192	3	<input type="checkbox"/> Automated Flagger Assistance Devices	Jan. 1, 2008	April 1, 2023
	80173	4	<input type="checkbox"/> Bituminous Materials Cost Adjustments	Nov. 2, 2006	Aug. 1, 2017
	80426	5	<input type="checkbox"/> Bituminous Surface Treatment with Fog Seal	Jan. 1, 2020	Jan. 1, 2022
*	80241	6	<input type="checkbox"/> Bridge Demolition Debris	July 1, 2009	
*	50531	7	<input type="checkbox"/> Building Removal	Sept. 1, 1990	Aug. 1, 2022
*	50261	8	<input type="checkbox"/> Building Removal with Asbestos Abatement	Sept. 1, 1990	Aug. 1, 2022
	80449	9	<input type="checkbox"/> Cement, Type II	Aug. 1, 2023	
	80384	10	<input type="checkbox"/> Compensable Delay Costs	June 2, 2017	April 1, 2019
*	80198	11	<input type="checkbox"/> Completion Date (via calendar days)	April 1, 2008	
*	80199	12	<input type="checkbox"/> Completion Date (via calendar days) Plus Working Days	April 1, 2008	
	80453	13	<input type="checkbox"/> Concrete Sealer	Nov. 1, 2023	
	80261	14	<input type="checkbox"/> Construction Air Quality – Diesel Retrofit	June 1, 2010	Nov. 1, 2014
	80434	15	<input type="checkbox"/> Corrugated Plastic Pipe (Culvert and Storm Sewer)	Jan. 1, 2021	
*	80029	16	<input type="checkbox"/> Disadvantaged Business Enterprise Participation	Sept. 1, 2000	Mar. 2, 2019
	80229	17	<input type="checkbox"/> Fuel Cost Adjustment	April 1, 2009	Aug. 1, 2017
	80452	18	<input type="checkbox"/> Full Lane Sealant Waterproofing System	Nov. 1, 2023	
	80447	19	<input type="checkbox"/> Grading and Shaping Ditches	Jan. 1, 2023	
	80433	20	<input type="checkbox"/> Green Preformed Thermoplastic Pavement Markings	Jan. 1, 2021	Jan. 1, 2022
	80443	21	<input type="checkbox"/> High Tension Cable Median Barrier Removal	April 1, 2022	
	80456	22	<input type="checkbox"/> Hot-Mix Asphalt	Jan. 1, 2024	
	80446	23	<input type="checkbox"/> Hot-Mix Asphalt - Longitudinal Joint Sealant	Nov. 1, 2022	Aug. 1, 2023
	80438	24	<input type="checkbox"/> Illinois Works Apprenticeship Initiative – State Funded Contracts	June 2, 2021	Sept. 2, 2021
	80045	25	<input type="checkbox"/> Material Transfer Device	June 15, 1999	Jan. 1, 2022
	80450	26	<input type="checkbox"/> Mechanically Stabilized Earth Retaining Walls	Aug. 1, 2023	
	80441	27	<input type="checkbox"/> Performance Graded Asphalt Binder	Jan. 1, 2023	
	80451	28	<input type="checkbox"/> Portland Cement Concrete	Aug. 1, 2023	
*	34261	29	<input type="checkbox"/> Railroad Protective Liability Insurance	Dec. 1, 1986	Jan. 1, 2022
	80455	30	<input type="checkbox"/> Removal and Disposal of Regulated Substances	Jan. 1, 2024	
	80445	31	<input type="checkbox"/> Seeding	Nov. 1, 2022	
	80448	32	<input type="checkbox"/> Source of Supply and Quality Requirements	Jan. 2, 2023	
	80340	33	<input type="checkbox"/> Speed Display Trailer	April 2, 2014	Jan. 1, 2022
	80127	34	<input type="checkbox"/> Steel Cost Adjustment	April 2, 2004	Jan. 1, 2022
	80397	35	<input type="checkbox"/> Subcontractor and DBE Payment Reporting	April 2, 2018	
	80391	36	<input type="checkbox"/> Subcontractor Mobilization Payments	Nov. 2, 2017	April 1, 2019
	80437	37	<input type="checkbox"/> Submission of Payroll Records	April 1, 2021	Nov. 2, 2023
	80435	38	<input type="checkbox"/> Surface Testing of Pavements – IRI	Jan. 1, 2021	Jan. 1, 2023
	80410	39	<input type="checkbox"/> Traffic Spotters	Jan. 1, 2019	
*	20338	40	<input type="checkbox"/> Training Special Provisions	Oct. 15, 1975	Sept. 2, 2021
	80429	41	<input type="checkbox"/> Ultra-Thin Bonded Wearing Course	April 1, 2020	Jan. 1, 2022
	80439	42	<input type="checkbox"/> Vehicle and Equipment Warning Lights	Nov. 1, 2021	Nov. 1, 2022
	80302	43	<input type="checkbox"/> Weekly DBE Trucking Reports	June 2, 2012	Nov. 1, 2021
	80454	44	<input type="checkbox"/> Wood Sign Support	Nov. 1, 2023	
	80427	45	<input type="checkbox"/> Work Zone Traffic Control Devices	Mar. 2, 2020	
*	80071	46	<input type="checkbox"/> Working Days	Jan. 1, 2002	

Highlighted items indicate a new or revised special provision for the letting.

An * indicates the special provision requires additional information from the designer, which needs to be submitted separately. The Project Coordination and Implementation Section will then include the information in the applicable special provision.

The following special provisions are in the 2024 Supplemental Specifications and Recurring Special Provisions.

<u>File Name</u>	<u>Special Provision Title</u>	<u>New Location(s)</u>	<u>Effective</u>	<u>Revised</u>
80436	Blended Finely Divided Minerals	Articles 1010.01 & 1010.06	April 1, 2021	
80440	Waterproofing Membrane System	Article 1061.05	Nov. 1, 2021	

"General Decision Number: IL20240009 01/05/2024

Superseded General Decision Number: IL20230009

State: Illinois

Construction Types: Building, Heavy, Highway and Residential

County: Cook County in Illinois.

BUILDING, RESIDENTIAL, HEAVY, AND HIGHWAY PROJECTS (does not include landscape projects).

Note: Contracts subject to the Davis-Bacon Act are generally required to pay at least the applicable minimum wage rate required under Executive Order 14026 or Executive Order 13658.

Please note that these Executive Orders apply to covered contracts entered into by the federal government that are subject to the Davis-Bacon Act itself, but do not apply to contracts subject only to the Davis-Bacon Related Acts, including those set forth at 29 CFR 5.1(a)(1).

If the contract is entered into on or after January 30, 2022, or the contract is renewed or extended (e.g., an option is exercised) on or after January 30, 2022, Executive Order 14026 generally applies to the contract. The contractor must pay all covered workers at least the applicable minimum wage rate.

after January 30, 2022:	least \$17.20 per hour (or		
	the applicable wage rate		
	listed on this wage		
	determination, if it is		
	higher) for all hours		
	spent performing on the		
	contract in 2024.		
_____		_____	

If the contract was awarded on	. Executive Order 13658		
or between January 1, 2015 and	generally applies to the		
January 29, 2022, and the	contract.		
contract is not renewed or	. The contractor must pay all		
extended on or after January	covered workers at least		
30, 2022:	\$12.90 per hour (or the		
	applicable wage rate listed		
	on this wage determination,		
	if it is higher) for all		
	hours spent performing on		
	that contract in 2024.		
_____		_____	

The applicable Executive Order minimum wage rate will be adjusted annually. If this contract is covered by one of the Executive Orders and a classification considered necessary for performance of work on the contract does not appear on this wage determination, the contractor must still submit a conformance request.

Additional information on contractor requirements and worker

protections under the Executive Orders is available at
<http://www.dol.gov/whd/govcontracts>.

Modification Number Publication Date

0 01/05/2024

ASBE0017-001 06/01/2021

Rates Fringes

ASBESTOS WORKER/INSULATOR

Includes the application
of all insulating
materials, protective
coverings, coatings, and
finishes to all types of

mechanical systems.....\$ 51.80 30.60

Fire Stop Technician.....\$ 41.44 27.85

HAZARDOUS MATERIAL HANDLER

includes preparation,
wetting, stripping removal
scrapping, vacuuming,
bagging and disposal of
all insulation materials,
whether they contain
asbestos or not, from

mechanical systems.....\$ 38.85 27.85

BOIL0001-001 05/01/2021

Rates Fringes

BOILERMAKER.....\$ 52.61 33.07

BRIL0021-001 06/01/2016

Rates Fringes

BRICKLAYER.....\$ 44.88 26.62

BRIL0021-004 06/01/2017

Rates Fringes

Marble Mason.....\$ 44.63 26.83

BRIL0021-006 06/01/2017

Rates Fringes

TERRAZZO WORKER/SETTER.....\$ 44.38 25.84

TILE FINISHER.....\$ 38.56 22.10

TILE SETTER.....\$ 45.49 25.72

BRIL0021-009 06/01/2017

Rates Fringes

MARBLE FINISHER.....\$ 33.95 26.03

BRIL0021-012 06/01/2017

Rates Fringes

Pointer, cleaner and caulker....\$ 45.42 24.06

CARP0555-001 06/01/2022

BUILDING, HEAVY, AND HIGHWAY

Rates Fringes

CARPENTER

Carpenter, Lather,

Millwright, Piledriver,

and Soft Floor Layer

Building.....\$ 52.01 38.85

Heavy & Highway.....\$ 52.01 38.85

CARP0555-002 10/01/2023

RESIDENTIAL CONSTRUCTION

Rates Fringes

CARPENTER.....\$ 45.61 35.31

ELEC0009-003 05/28/2023

Rates Fringes

Line Construction

Groundman.....\$ 46.92 60.91%

Lineman and Equipment

Operator.....\$ 60.15 60.91%

ELEC0134-001 06/06/2022

Rates Fringes

ELECTRICIAN.....\$ 52.05 39.12

ELEC0134-003 06/05/2023

Rates Fringes

ELECTRICIAN

ELECTRICAL TECHNICIAN.....\$ 48.66 30.86

The work shall consist of the installation, operation, inspection, maintenance, repair and service of radio, television, recording, voice sound vision production and reproduction, telephone and telephone interconnect, facsimile, data apparatus, coaxial, fibre optic and wireless equipment, appliances and systems used for the

transmission and reception of signals of any nature, business, domestic, commercial, education, entertainment and residential purposes, including but not limited to communication and telephone, electronic and sound equipment, fibre optic and data communication systems, and the performance of any task directly related to such installation or service whether at new or existing sites, such tasks to include the placing of wire and cable and electrical power conduit or other raceway work within the equipment room and pulling wire and/or cable through conduit and the installation of any incidental conduit.

ELEV0002-001 01/01/2023

Rates Fringes

ELEVATOR MECHANIC.....\$ 65.12 37.335+a+b

FOOTNOTES:

a) PAID HOLIDAYS: New Year's Day; Memorial Day; Independence Day; Labor Day; Thanksgiving Day; Day after Thanksgiving Day; Veterans' Day and Christmas Day.

b) Employer contributes 8% of regular hourly rate as vacation pay credit for employee with more than 5 years of service, and 6% for employee with less than 5 years service

ENGI0150-006 06/01/2023

Building and Residential Construction

Rates Fringes

OPERATOR: Power Equipment

GROUP 1.....	\$ 56.60	47.70
GROUP 2.....	\$ 55.30	47.70
GROUP 3.....	\$ 52.75	47.70
GROUP 4.....	\$ 51.00	47.70

POWER EQUIPMENT OPERATORS CLASSIFICATIONS

GROUP 1: Mechanic; Asphalt Plant*; Asphalt Spreader;
Autograde*; Backhoes with Caisson attachment*; Batch Plant*;
Benoto(Requires two Engineers); Boiler and Throttle Valve;
Caisson Rigs*; Central Redi-Mix Plant*; Combination Backhoe
Front Endloader Machine; Compressor and Throttle Valve;
Concrete Breaker (Truck Mounted)*; Concrete Conveyor;
Concrete Conveyor, Truck Mounted; Concrete Paver over 27E
cu. ft.*; Concrete Paver 27E cu ft and Under*; Concrete
Placer*; Concrete Placing Boom; Concrete Pump (Truck
Mounted); Concrete Tower; Cranes*; Cranes, Hammerhead*;
Cranes, (GCI and similar type Requires two operators only);
Creter Crane; Crusher, Stone, etc; Derricks; Derricks,
Traveling*; Formless Curb and Gutter Machine*; Grader,
Elevating; Grouting Machines; Highlift Shovels or Front

Endloader 2 1/4 yd. and over; Hoists, Elevators, Outside Type Rack and pinion and similar Machines; Hoists, One, Two, and Three Drum; Hoists, Two Tugger One Floor; Hydraulic Backhoes*; Hydraulic Boom Trucks; Hydraulic Vac (and similar equipment); Locomotives; Motor Patrol*; Pile Drivers and Skid Rig*; Post Hole Digger; Pre- Stress Machine; Pump Cretes Dual Ram (Requiring frequent Lubrication and Water); Pump Cretes; Squeeze Cretes-Screw Type Pumps Gypsum Bulker and Pump; Raised and Blind Hole Drill*; Roto Mill Grinder (36" and Over)*; Roto Mill Grinder (Less Than 36")*; Scoops-Tractor Drawn; Slip-Form Paver*; Straddle Buggies; Tournapull; Tractor with Boom, and Side Boom; and Trenching Machines*.

GROUP 2: Bobcat (over 3/4 cu yd); Boilers; Broom, Power Propelled; Bulldozers; Concrete Mixer (Two Bag and over); Conveyor, Portable; Forklift Trucks; Greaser Engineer; Highlift Shovels or Front End loaders under 2 1/4 cu yd; Automatic Hoists, Hoists, Inside Elevators; Hoists, Sewer Dragging Machine; Hoists, Tugger Single Drum; Laser Screed; Rock Drill (Self-Propelled); Rock Drill (Truck Mounted)*; Rollers; Steam Generators; Tractors; Tractor Drawn Vibratory Roller (Receives an additional \$.50 per hour); Winch Trucks with "A" Frame.

GROUP 3: Air Compressor-Small 250 and Under (1 to 5 not to exceed a total of 300 ft); Air Compressor-Large over 250; Combination-Small Equipment Operator; Generator- Small 50 kw and under; Generator-Large over 50 kw; Heaters,

Mechanical; Hoists, Inside Elevators (Remodeling or Renovatin work); Hydrualic Power Units (Pile Driving, Extracting, and Drilling); Low Boys; Pumps Over 3''' (1 To 3 not to exceed a total of 300 ft); Pumps, Well Points; Welding Machines (2 through 5); Winches, 4 Small Electric Drill Winches; Bobcat (up to and including 3/4 cu yd)

GROUP 4 - Bobcats and/or other Skid Steer Loaders; Brick Forklifts; Oilers

*-Requires Oiler

ENGI0150-025 06/01/2023

Heavy and Highway Construction

Rates Fringes

OPERATOR: Power Equipment

GROUP 1.....	\$ 54.80	47.70
GROUP 2.....	\$ 54.25	47.70
GROUP 3.....	\$ 52.20	47.70
GROUP 4.....	\$ 50.80	47.70
GROUP 5.....	\$ 49.60	47.70

POWER EQUIPMENT OPERATOR CLASSIFICATIONS

GROUP 1: Asphalt Plant*; Asphalt Heater and Planer

combination; Asphalt Heater Scarfire*, Asphalt Spreader; Autograder/ GOMACO or similar; ABG Paver*, Backhoes with Caisson attachment*, Ballast Regulator, Belt Loader*; Caisson Rigs*Car Dumper, Central Redi-Mix Plant*, Combination Backhoe; Front End Loader Machine (1 cu yd or over Backhoe bucket or with attachments); Concrete Breaker (truck mounted); Concrete Conveyor; Concrete Paver over 27E cu ft*; Concrete Placer*; Concrete Tube Float; Cranes, all attachments*; Cranes, Hammerhead, Linden, Peco and machines of a like nature*; Creter Crane; Crusher, stone; All Derricks; Derrick Boats; Derricks, traveling*; Dowell Machine with Air Compressor (\$1.00 above Class 1); Dredges*; Field Mechanic Welder; Formless Curb and Gutter Machine*; Gradall and machines of a like nature*; Grader, Elevating; Grader, Motor Grader, Motor Patrol, Auto Patrol, Form Grader, Pull Grader, Subgrader; Guard Rail Post Driver mounted*; Hoists, one, two, and three Drum; Hydraulic Backhoes*; Backhoes with Shear attachments*; Mucking Machine; Pile Drivers and Skid Rig*; Pre-Stress Machine; Pump Cretes Dual Ram (requires frequent lubrication and water)*; Rock Drill- Crawler or Skid Rig*; Rock Drill truck mounted*; Rock/ Track Tamper; Roto Mill Grinder, (36" and over)*; Slip-Form Paver*; Soil Test Drill Rig, truck mounted*; Straddle Buggies; Hydraulic Telescoping Form (tunnel); Tractor Drawn Belt Loader*; Tractor Drawn Belt Loader with attached Pusher (two engineers); Tractor with boom; Tractaire with attachment; Traffic Barrier Transfer Machine*; Trenching Machine; Truck Mounted Concrete Pump with boom*; Underground Boring and/or Mining Machines 5 ft

in diameter and over tunnel, etc.*; Wheel Excavator* &
Widener (Apsco); Raised or Blind Hoe Drill, Tunnel & Shaft*

GROUP 2: Batch Plant*; Bituminous Mixer; Boiler and Throttle
Valve; Bulldozer; Car Loader Trailing Conveyors;
Combination Backhoe Front End Loader Machine, (less than 1
cu yd Backhoe Bucket with attachments); Compressor and
Throttle Valve; Compressor, common receiver (3); Concrete
Breaker or Hydro Hammer; Concrete Grinding Machine;
Concrete Mixer or Paver 7S series to and including 27 cu
ft; Concrete Spreader; Concrete Curing Machine; Burlap
Machine; Belting Machine and Sealing Machine; Concrete
Wheel Saw; Conveyor Muck Cars (Haglund or similar type);
Drills (all); Finishing Machine-Concrete; Greaser Engineer;
Highlift Shovels or Front End Loader; Hoist- Sewer Dragging
Machine; Hydraulic Boom Trucks, all attachments;
Hydro-Blaster (requires two operators); Laser Screed*;
Locomotives, Dinky; Off-Road Hauling Units (including
articulating); Pump Cretes; Squeeze Cretes-Screw Type
pumps, Gypsum Bulker and Pump; Roller Asphalt; Rotary Snow
Plows; Rototiller, Seaman, self-Propelled; Scoops-Tractor
Drawn; Self- propelled Compactor; Spreader-Chip-Stone;
Scraper; Scraper-Prime Mover in Tandem regardless of size
(add \$1.00 to Group 2 hourly rate for each hour and for
each machine attached thereto add \$1.00 to Group 2 hourly
rate for each hour); Tank Car Heater; Tractors, Push,
pulling Sheeps Foot, Disc, or Compactor, etc; Tug Boats

GROUP 3: Boilers; Brooms, all power propelled; Cement Supply

Tender; Compressor, Common Receiver (2); Concrete Mixer, two bag and over; Conveyor, Portable; Farm type Tractors used for mowing, seeding, etc; Fireman on Boilers; Forklift Trucks; Grouting Machines; Hoists, Automatic; Hoists, all Elevators; Hoists, Tugger single Drum; Jeep Diggers; Low Boys; Pipe Jacking Machines; Post-hole Digger; Power Saw, Concrete, Power Driven; Pug Mills; Rollers, other than asphalt; Seed and Straw Blower; Steam Generators; Stump Machine; Winch Trucks with A-Frame; Work Boats; Tamper-Form motor driven

GROUP 4: Air compressor - Small 250 and under (1 to 5 not to exceed a total of 300 ft); Air Compressor - Large over 250; Combination - Small Equipment Operator; Directional Boring Machine; Generators - Small 50 kw and under; Generators - Large , over 50 kw; Heaters, Mechanical; Hydraulic power unit (Pile Driving, Extracting or Drilling); Light Plants (1 to 5); Pumps, over 3"" (1 to 3, not to exceed a total of 300 ft); Pumps, Well Points; Tractaire; Welding Machines (2 through 5); Winches, 4 small electric drill winches;

GROUP 5: Bobcats (All); Brick Forklifts; Oilers; Directional Boring

*Requires Oiler

Rates Fringes

IRONWORKER

Sheeter.....	\$ 57.25	43.75
Structural and Reinforcing..	\$ 57.00	43.75

IRON0063-001 06/01/2023

Rates Fringes

IRONWORKER, ORNAMENTAL.....	\$ 55.01	42.23
-----------------------------	----------	-------

IRON0063-002 06/01/2023

Rates Fringes

IRONWORKER

Fence Erector.....	\$ 48.48	32.75
--------------------	----------	-------

IRON0136-001 07/01/2023

Rates Fringes

IRONWORKER

Machinery Movers; Riggers;		
Machinery Erectors.....	\$ 48.00	42.69
Master Riggers.....	\$ 50.50	42.69

LABO0002-006 06/01/2022

Rates Fringes

LABORER (BUILDING &
RESIDENTIAL)

GROUP 1.....	\$ 47.40	33.16
GROUP 2.....	\$ 47.40	33.16
GROUP 3.....	\$ 47.48	33.16
GROUP 4.....	\$ 47.50	33.16
GROUP 5.....	\$ 47.55	33.16
GROUP 6.....	\$ 47.60	33.16
GROUP 7.....	\$ 47.63	33.16
GROUP 8.....	\$ 47.73	33.16
GROUP 9.....	\$ 47.75	33.16
GROUP 10.....	\$ 47.85	33.16
GROUP 11.....	\$ 47.68	33.16
GROUP 12.....	\$ 48.40	33.16

LABORER CLASSIFICATIONS

GROUP 1: Building Laborers; Plasterer Tenders; Pumps for
Dewatering; and other unclassified laborers.

GROUP 2: Fireproofing and Fire Shop laborers.

GROUP 3: Cement Gun.

GROUP 4: Chimney over 40 ft.; Scaffold Laborers.

GROUP 5: Cement Gun Nozzle Laborers (Gunite); Windlass and capstan person.

GROUP 6: Stone Derrickmen & Handlers.

GROUP 7: Jackhammermen; Power driven concrete saws; and other power tools.

GROUP 8: Firebrick & Boiler Laborers.

GROUP 9: Chimney on fire brick; Caisson diggers; & Well Point System men.

GROUP 10: Boiler Setter Plastic Laborers.

GROUP 11: Jackhammermen on fire brick work only.

GROUP 12: Dosimeter use (any device) monitoring nuclear exposure); Asbestos Abatement Laborer; Toxic and Hazardous Waste Removal Laborers.

LABO0002-007 06/01/2022

Rates Fringes

LABORER (HEAVY & HIGHWAY)

GROUP 1.....\$ 47.40 33.16

GROUP 2.....\$ 47.48 33.16

GROUP 3.....	\$ 47.55	33.16
GROUP 4.....	\$ 47.68	33.16
GROUP 5.....	\$ 47.40	33.16

LABORER CLASSIFICATIONS

GROUP 1: Common laborer; Tenders; Material expeditor (asphalt plant); Street paving, Grade separation, sidewalk, curb & gutter, strippers & All laborers not otherwise mentioned

GROUP 2: Asphalt tampers & smoothers; Cement gun laborers

GROUP 3: Cement Gun Nozzle (laborers), Gunitite

GROUP 4: Rakers, Lutemen; Machine-Screwmen; Kettlemen; Mixermen; Drun-men; Jackhammermen (asphalt); Paintmen; Mitre box spreaders; Laborers on birch, overman and similar spreader equipment; Laborers on APSCO; Laborers on air compressor; Paving Form Setter; Jackhammermen (concrete); Power drive concrete saws; other power tools.

GROUP 5: Asbestos Abatement Laborers; Toxic and Hazardous Waste Removal Laborers, Dosimeter (any device) monitoring nuclear exposure

Rates Fringes

LABORER (Compressed Air)

0 - 15 POUNDS.....	\$ 48.40	33.16
16 - 20 POUNDS.....	\$ 48.90	33.16
21 - 26 POUNDS.....	\$ 49.40	33.16
27 - 33 POUNDS.....	\$ 50.40	33.16
34 - AND OVER.....	\$ 51.40	33.16

LABORER (Tunnel and Sewer)

GROUP 1.....	\$ 47.40	33.16
GROUP 2.....	\$ 47.53	33.16
GROUP 3.....	\$ 47.63	33.16
GROUP 4.....	\$ 47.75	33.16
GROUP 5.....	\$ 47.40	33.16

LABORER CLASSIFICATIONS (TUNNEL)

GROUP 1: Cage tenders; Dumpmen; Flagmen; Signalmen; Top laborers

GROUP 2: Air hoist operator; Key board operator; concrete laborer; Grout; Lock tenders (Free Air Side); Steel setters; Tuggers; Switchmen; Car pusher

GROUP 3: Concrete repairmen; Lock tenders (pressure side); Mortar men; Muckers; Grout machine operators; Track layers

GROUP 4: Air trac drill operator; Miner; Bricklayer tenders; Concrete blower operator; Drillers; Dynamiters; Erector

operator; Form men; Jackhammermen; Powerpac; Mining machine operators; Mucking machine operator; Laser beam operator; Liner plate and ring setters; Shield drivers; Power knife operator; Welder- burners; Pipe jacking machine operator; skimmers; Maintenance technician

GROUP 5: Asbestos abatement laborer; Toxic and hazardous waste removal laborer; Dosimeter (any device) monitoring nuclear exposure

LABORER CLASSIFICATIONS (SEWER)

GROUP 1: Signalmen; Top laborers and All other laborers

GROUP 2: Concrete laborers and Steel setters

GROUP 3: Cement carriers; Cement mixers; Concrete repairmen; Mortar men; Scaffold men; Second Bottom men

GROUP 4: Air trac drill operator; Bottom men; Bracers-bracing; Bricklayer tenders; Catch basin diggers; Drainlayers; dynamiters; Form men; Jackhammermen; Powerpac; Pipelayers; Rodders; Welder-burners; Well point systems men

GROUP 5: Asbestos abatement laborer, Toxic and hazardous waste removal laborer; Dosimeter (any device) monitoring nuclear exposure

LABO0225-001 06/01/2022

Rates Fringes

LABORER (DEMOLITION/WRECKING)

GROUP 1.....	\$ 42.40	33.16
GROUP 2.....	\$ 47.40	33.16
GROUP 3.....	\$ 47.40	33.16

LABORER CLASSIFICATIONS

GROUP 1 - Complete Demolition

GROUP 2 - Interior Wrecking and Strip Out Work

GROUP 3 - Asbestos Work with Complete Demolition/Wrecking or Strip Out Work

PAIN0014-001 06/01/2022

Rates Fringes

PAINTER (including taper).....	\$ 50.30	31.07
--------------------------------	----------	-------

PAIN0027-001 06/01/2022

Rates Fringes

GLAZIER.....\$ 48.75 41.32

PLAS0005-002 07/01/2015

Rates Fringes

PLASTERER.....\$ 42.25 26.65

PLAS0502-001 06/01/2023

Rates Fringes

CEMENT MASON/CONCRETE FINISHER...\$ 50.75 40.59

PLUM0130-001 06/01/2023

Rates Fringes

PLUMBER.....\$ 56.80 36.02

PLUM0597-002 06/01/2023

Rates Fringes

PIPEFITTER.....\$ 55.00 38.62

ROOF0011-001 06/01/2023

Rates Fringes

ROOFER.....\$ 49.00 28.38

SFIL0281-001 01/01/2023

Rates Fringes

SPRINKLER FITTER.....\$ 54.55 33.65

SHEE0073-001 06/01/2022

Rates Fringes

Sheet Metal Worker.....\$ 49.10 42.91

SHEE0073-002 06/08/2018

Rates Fringes

Sheet Metal Worker

ALUMINUM GUTTER WORK.....\$ 31.32 37.02

TEAM0731-001 06/01/2017

COOK COUNTY - HEAVY AND HIGHWAY

Rates Fringes

TRUCK DRIVER

2 or 3 Axles.....	\$ 35.60	22.10
4 Axles.....	\$ 35.85	22.10
5 Axles.....	\$ 36.05	22.10
6 Axles.....	\$ 36.25	22.10

FOOTNOTES:

A. Paid Holidays: New Year's Day, Memorial Day, Independence Day, Labor Day, Thanksgiving Day, and Christmas Day.

B. 900 straight time hours or more in 1 calendar year for the same employer shall receive 1 week paid vacation; 3 years - 2 weeks paid vacation; 10 years - 3 weeks paid vacation; 20 years - 4 weeks paid vacation.

C. An additional \$.20 per axle shall be paid for all vehicles with more than six (6) axles.

TEAM0731-002 04/01/2023

Rates Fringes

Traffic Control Device Monitor

TRAFFIC SAFETY WORKER:

Primary duties include but

are not limited to the

delivery, maintenance and

pick-up of traffic control devices, the set-up and installation of traffic signs, pavement markings, barricades, crash barrels and glare screens, traffic control surveillance, the repair and maintenance trucks, cars, arrow boards, message signs, barricade and sign fabrication equipment.....\$ 40.10 20.95

TEAM0786-001 06/01/2017

COOK COUNTY - BUILDING AND RESIDENTIAL

Rates Fringes

TRUCK DRIVER

2 & 3 Axles.....	\$ 39.942	0.25+a
4 Axles.....	\$ 39.75	0.25+a
5 Axles.....	\$ 39.967	0.25+a
6 Axles.....	\$ 40.184	0.25+a

FOOTNOTES:

a. \$719.00 per week.

An additional \$.20 per axle shall be paid for all vehicles with more than six (6) axles.

Paid Holidays: New Year's Day, Memorial Day, Independence Day, Labor Day, Thanksgiving Day, and Christmas Day.

900 straight time hours or more in 1 calendar year for the same employer shall receive 1 week paid vacation; 3 years - 2 weeks paid vacation; 10 years - 3 weeks paid vacation; 20 years - 4 weeks paid vacation.

WELDERS - Receive rate prescribed for craft performing operation to which welding is incidental.

=====

Note: Executive Order (EO) 13706, Establishing Paid Sick Leave for Federal Contractors applies to all contracts subject to the Davis-Bacon Act for which the contract is awarded (and any solicitation was issued) on or after January 1, 2017. If this contract is covered by the EO, the contractor must provide employees with 1 hour of paid sick leave for every 30 hours they work, up to 56 hours of paid sick leave each year. Employees must be permitted to use paid sick leave for their own illness, injury or other health-related needs, including preventive care; to assist a family member (or person who is like family to the employee) who is ill, injured, or has other

health-related needs, including preventive care; or for reasons resulting from, or to assist a family member (or person who is like family to the employee) who is a victim of, domestic violence, sexual assault, or stalking. Additional information on contractor requirements and worker protections under the EO is available at <https://www.dol.gov/agencies/whd/government-contracts>.

Unlisted classifications needed for work not included within the scope of the classifications listed may be added after award only as provided in the labor standards contract clauses (29CFR 5.5 (a) (1) (iii)).

The body of each wage determination lists the classification and wage rates that have been found to be prevailing for the cited type(s) of construction in the area covered by the wage determination. The classifications are listed in alphabetical order of ""identifiers"" that indicate whether the particular rate is a union rate (current union negotiated rate for local), a survey rate (weighted average rate) or a union average rate (weighted union average rate).

Union Rate Identifiers

A four letter classification abbreviation identifier enclosed

in dotted lines beginning with characters other than ""SU"" or ""UAVG"" denotes that the union classification and rate were prevailing for that classification in the survey. Example: PLUM0198-005 07/01/2014. PLUM is an abbreviation identifier of the union which prevailed in the survey for this classification, which in this example would be Plumbers. 0198 indicates the local union number or district council number where applicable, i.e., Plumbers Local 0198. The next number, 005 in the example, is an internal number used in processing the wage determination. 07/01/2014 is the effective date of the most current negotiated rate, which in this example is July 1, 2014.

Union prevailing wage rates are updated to reflect all rate changes in the collective bargaining agreement (CBA) governing this classification and rate.

Survey Rate Identifiers

Classifications listed under the ""SU"" identifier indicate that no one rate prevailed for this classification in the survey and the published rate is derived by computing a weighted average rate based on all the rates reported in the survey for that classification. As this weighted average rate includes all rates reported in the survey, it may include both union and non-union rates. Example: SULA2012-007 5/13/2014. SU indicates the rates are survey rates based on a weighted average calculation of rates and are not majority rates. LA indicates the State of Louisiana. 2012 is the year of survey on which

these classifications and rates are based. The next number, 007 in the example, is an internal number used in producing the wage determination. 5/13/2014 indicates the survey completion date for the classifications and rates under that identifier.

Survey wage rates are not updated and remain in effect until a new survey is conducted.

Union Average Rate Identifiers

Classification(s) listed under the UAVG identifier indicate that no single majority rate prevailed for those classifications; however, 100% of the data reported for the classifications was union data. EXAMPLE: UAVG-OH-0010 08/29/2014. UAVG indicates that the rate is a weighted union average rate. OH indicates the state. The next number, 0010 in the example, is an internal number used in producing the wage determination. 08/29/2014 indicates the survey completion date for the classifications and rates under that identifier.

A UAVG rate will be updated once a year, usually in January of each year, to reflect a weighted average of the current negotiated/CBA rate of the union locals from which the rate is based.

WAGE DETERMINATION APPEALS PROCESS

1.) Has there been an initial decision in the matter? This can be:

- * an existing published wage determination
- * a survey underlying a wage determination
- * a Wage and Hour Division letter setting forth a position on a wage determination matter
- * a conformance (additional classification and rate) ruling

On survey related matters, initial contact, including requests for summaries of surveys, should be with the Wage and Hour National Office because National Office has responsibility for the Davis-Bacon survey program. If the response from this initial contact is not satisfactory, then the process described in 2.) and 3.) should be followed.

With regard to any other matter not yet ripe for the formal process described here, initial contact should be with the Branch of Construction Wage Determinations. Write to:

Branch of Construction Wage Determinations
Wage and Hour Division
U.S. Department of Labor
200 Constitution Avenue, N.W.
Washington, DC 20210

2.) If the answer to the question in 1.) is yes, then an

interested party (those affected by the action) can request review and reconsideration from the Wage and Hour Administrator (See 29 CFR Part 1.8 and 29 CFR Part 7). Write to:

Wage and Hour Administrator
U.S. Department of Labor
200 Constitution Avenue, N.W.
Washington, DC 20210

The request should be accompanied by a full statement of the interested party's position and by any information (wage payment data, project description, area practice material, etc.) that the requestor considers relevant to the issue.

3.) If the decision of the Administrator is not favorable, an interested party may appeal directly to the Administrative Review Board (formerly the Wage Appeals Board). Write to:

Administrative Review Board
U.S. Department of Labor
200 Constitution Avenue, N.W.
Washington, DC 20210

4.) All decisions by the Administrative Review Board are final.

=====

END OF GENERAL DECISION"

**ILLINOIS DEPARTMENT OF NATURAL RESOURCES
OFFICE OF WATER RESOURCES
ONE NATURAL RESOURCE WAY
SPRINGFIELD, ILLINOIS 62702-1271**

REGIONAL PERMIT NO. 3

**AUTHORIZING CONSTRUCTION OF MINOR PROJECTS
IN NORTHEASTERN ILLINOIS REGULATORY FLOODWAYS**

INTRODUCTION

Under the provisions of 17 Illinois Administrative Code, Part 3708, any construction within a regulatory floodway in Cook, DuPage, Kane, Lake, McHenry and Will counties requires a permit from the Illinois Department of Natural Resources, Office of Water Resources and from the local unit of government having jurisdiction.

The Part 3708 rules allow the Department to issue regional permits for specific activities which would not singularly or cumulatively result in increased flood stage or velocity. Subsequent to the effective date of this regional permit, it will not be necessary to submit applications to, or obtain individual permits from, the Department of Natural Resources, Office of Water Resources for those activities listed which meet the specified terms and conditions.

The Part 3708 rules require that all floodway construction applications be prepared and reviewed by a registered professional engineer. The registered professional engineer's preparation and review required by the Part 3708 rules is waived for projects meeting the terms and conditions of this regional permit.

APPLICABILITY

Except as noted, this regional permit applies to the construction of the specified projects within regulatory floodways designated by the Department of Natural Resources, Office of Water Resources pursuant to 17 Illinois Administrative Code, Part 3708 (Lake Michigan is not included).

TERMS AND CONDITIONS FOR SPECIFIC PROJECT TYPES

Underground and Overhead Utilities

To be authorized by this permit, underground and overhead utilities must meet the following criteria:

- (a) The construction of the utility must not result in any increase in existing ground elevations.
- (b) The construction of the utility must not involve the placement of above ground structures in the floodway other than supporting towers for overhead utilities.
- (c) In the case of underground stream crossings, the top of the pipe or encasement must be buried a minimum of three (3) feet below the existing stream bed.
- (d) In the case of overhead utilities, supporting towers are not to be placed in the watercourse and shall be designed not to catch debris.
- (e) Disturbance of streamside vegetation shall be kept to a minimum during construction to prevent erosion and sedimentation. All disturbed floodway areas, including the stream banks, shall be restored to their original contours and seeded or otherwise stabilized upon completion of construction.
- (f) A utility crossing carrying material which may cause water pollution as defined by the Environmental Protection Act, 415 ILCS 5 (1996 State Bar Edition) shall be provided with shut-off valves on each side of the body of water to be crossed.
- (g) If blasting is to be utilized in the construction of the crossing, the Permittee shall notify the Department of Natural Resources, Office of Resource Conservation at least (10) days prior to the blasting date to allow monitoring of any related fish kills.
- (h) This regional permit does not authorize utility crossings of the Kankakee River, Fox River and the Fox Chain O' Lakes, Chicago River, South Branch Chicago River, South Fork of South Branch Chicago River, West Fork of South Branch Chicago River, Ogden Slip, Chicago Sanitary and Ship Canal, North Branch Chicago River from its mouth to its junction with the North Shore Channel, North Shore Channel, North Branch Canal, Des Plaines River from its mouth to Lockport Lock, Lake Calumet, Lake Calumet entrance channel, Calumet-Sag Channel, Calumet River, Grand Calumet, and the Little Calumet River from its mouth to its junction with the Calumet-Sag Channel.

Storm and Sanitary Sewer Outfalls and Outlet Channels

To be authorized by this permit, storm and sanitary sewer outfalls and outlet channels must meet the following criteria:

- (a) The outfall must not project riverward or lakeward of the existing adjacent natural bank slope or bulkhead.
- (b) Construction of outfalls and outlet channels must not result in an increase in ground elevation in the floodway.
- (c) The outfall or outlet channel must not cause stream erosion at the discharge location.
- (d) The velocity of the discharge shall not exceed the scour velocity of the channel soil, unless channel erosion would be prevented by the use of riprap or other design measures.
- (e) Outlets from drainage ditches shall not be opened to a stream until the ditch is vegetated or otherwise stabilized to minimize stream sedimentation.
- (f) The outlet jet shall not be a hazard to navigation.
- (g) The outlet discharge capacity shall not exceed 1,000 cubic feet per second.
- (h) Bank erosion shall be prevented by aprons, energy dissipators or drop structures as necessary.
- (i) Disturbance of streamside vegetation shall be kept to a minimum during construction to prevent erosion and sedimentation. All disturbed floodway areas, including the stream banks, shall be restored to their original contours and seeded or otherwise stabilized upon completion of construction.

Sidewalks, Athletic Fields (excluding fences), Playground Equipment and Patios

To be authorized by this permit, sidewalks, athletic fields, playground equipment and patios must meet the following criteria:

- (a) No fencing or fill may be placed or built as part of the project.
- (b) Sidewalks, athletic fields and patios must be built at or below grade.
- (c) Playground equipment must be anchored to prevent flotation and must be non-obstructive to flood flows.
- (d) No sidewalks or equipment shall project riverward or lakeward of the bank or shore.

Shoreline and Streambank Protection

To be authorized by this permit, construction of shoreline and streambank protection must meet the following criteria:

- (a) Only the following materials may be utilized: Stone and concrete riprap, steel sheet piling, cellular blocks, fabric-formed concrete, gabion baskets, rock and wire mattresses, sand/cement filled bags, geotechnical fabric materials, natural vegetation and treated timber.
- (b) The length of shoreline or streambank to be protected shall not exceed one thousand (1000) feet.
- (c) All material utilized shall be properly sized or anchored to resist anticipated forces of current and wave action.
- (d) Materials shall be placed in a way which would not cause erosion or the accumulation of debris on properties adjacent to or opposite the project.
- (e) Materials shall not be placed higher than the existing top of bank.
- (f) Materials shall be placed so that the modified cross-sectional area of the channel will conform to that of the natural channel upstream and downstream of the site. In no case shall the cross-sectional area of the natural channel be reduced. The bank may be graded to obtain a flatter slope and to lessen the quantity of material required.
- (g) If broken concrete is used, all protruding materials such as reinforcing rods shall be cut flush with the surface of the concrete and removed from the construction area.
- (h) Disturbance of vegetation shall be kept to a minimum during construction to prevent erosion and sedimentation. All disturbed areas shall be seeded or otherwise stabilized upon completion of construction.
- (i) In the case of seawalls and gabion structures on lakes, the structure shall be constructed at or landward of the water line as determined by the normal pool elevation.
- (j) This regional permit does not authorize filling for the purpose of converting public water to private use.

Minor non-commercial boat docks

- (a) The boat dock must not project more than 50 feet into a waterway, and in no instance greater than 1/4 of the width of the waterway, and shall not extend beyond any established navigation limits of the Department of Natural Resources and the Corps of Engineers.
- (b) The width of the boat dock must not be greater than 10 feet.
- (c) For L-shaped or T-shaped docks, the length of that portion parallel to the shoreline must not exceed 50 percent of the landowner's shoreline frontage, nor be greater than 50 feet in length.
- (d) Docks must be aligned so as not to cross the straight-line projection of property lines into the waterway or come within 10 feet of the straight-line projection of the property line.
- (e) Seasonal shore stations/boat lifts must be located adjacent to a boat dock or seawall and must not cross the straight-line projection of the property lines.
- (f) Dock posts must be marked by reflective devices. It is recommended that navigation indicator colors not be used.
- (g) The boat dock must be securely anchored to prevent its detachment and becoming a floating hazard during times of high water or winds.
- (h) Metal drums or containers may not be used as buoyancy units unless they are filled with flotation foam. Containers which previously stored pesticides, herbicides, or any other toxic chemicals are not permissible.
- (i) This permit does not authorize any other permanent structures, such as non-fabric roofs and elevated decks.
- (j) Nonfloating boat docks must be constructed in a manner which will minimize obstruction of flow.
- (k) If at any future date the Department of Natural Resources or the Corps of Engineers determines that the dock facility obstructs or impairs navigation, or in any way infringes upon the rights or interests of the public or any individual party, the permittee agrees to make necessary modifications to the dock as determined by the Department of Natural Resources or the Corps of Engineers.

GENERAL CONDITIONS

1. This permit is granted in accordance with the Rivers, Lakes and Streams Act, 615 ILCS 5.
2. This permit does not convey title to any Permittee or recognize title of any Permittee to any submerged or other lands, and furthermore, does not convey, lease or provide any right or rights of occupancy or use of the public or private property on which the project or any part thereof will be located, or otherwise granted to any Permittee any right or interest in or to the property whether the property is owned or possessed by the State of Illinois or by any private or public party or parties.
3. This permit does not release any Permittee from liability for damage to persons or property resulting from any activity covered by this permit, and does not authorize any injury to private property or invasion of private rights.
4. This permit does not relieve any Permittee of the responsibility to obtain other federal, state or local authorizations required for the construction of the permitted activity; and if any Permittee is required by law to obtain approval from any federal or other state agency to do the work, authorization granted by this permit is not effective until the federal and state approvals are obtained.
5. The Permittee shall, at the Permittee's own expense, remove all temporary piling, cofferdams, false work, and material incidental to the construction of the project, from the floodway in which the work is done. If the Permittee fails to remove such structures or materials, the Department may have removal made at the expense of the Permittee. If the activity is on a public body of water and if future need for public navigation or public interests, by the state or federal government, necessitates changes in any part of the structure or structures, such changes shall be made by and at the expense of the Permittee or Permittee's successors as required by the Department of Natural Resources or other properly constituted agency, within sixty (60) days from receipt of written notice of the necessity from the Department or other agency, unless a longer period of time is specifically authorized.
6. If a project authorized by this permit is located in or along a meandered lake, the Permittee and his successors shall make no claim whatsoever to any interest in any accretions caused by the project.
7. In issuing this permit, the Department of Natural Resources does not approve the adequacy of the design or structural strength of the structure or improvement authorized by this permit.

8. This Regional Permit shall remain in effect until such time as it is modified, suspended, or revoked by the Department of Natural Resources.

This Regional Permit was issued on July 25, 1990 and last modified or corrected May 15, 2003.

APPROVED:

Joel Brunsvold, Director
Department of Natural Resources

EXAMINED AND RECOMMENDED:

Martin J. Stralow, Manager
Division of Water Resource Management

APPROVAL RECOMMENDED:

Gary R. Clark, Acting Director
Office of Water Resources



DRURY LANE THEATRE

Group Sales/Catering Contract

Client/Organization Howard Mohr Community Center	Event Date 9/18/2024 (Wed)	Booking Contact Powers, Brenda	Sales Rep Zoë Michaels	Event # G04693
Address 7640 Jackson Blvd, Forest Park, IL 60130		Booking Tel (708) 771-7737	Booking Cell	Guests 25 (Pln)
Party Name The Audience	Theme Lunch & Show	Booking Email BPowers@forestpark.net	Gtd Guests 22	

Booking Information

Description	Serving	Show Time	Guests
Luncheon Served	11:30 am	1:30 pm	25 (Pln)

Theatre/Dining Items

Food/Service Items	Price	Qty	Total
Special Pricing: The Audience Theatre Ticket	50.05	24	1,201.20
Comp Theatre Ticket		1	
Three-Course Lunch	30.00	24	720.00
Comp Meal		1	

Terms & Conditions

- **A 10% non -refundable, non -transferable deposit is due fourteen days from receipt of this contract to secure your reservation.** Performance Tickets will not be held or reserved until the deposit and signed contract are received.
- **Final Payment is due two weeks prior to the contracted performance date** or tickets may be forfeited.
- Final payments can be made by check or credit card. Checks should be made payable to Drury Lane Events. **Any payments made with a credit card must be accompanied by a signed credit card authorization form and will include a 3% processing fee.**
- **Once final payment has been made, all sales are final.**
- Please confirm all dates, time, and guest guarantees listed herein are correct prior to signing.
- Drury Lane will only reduce the final guest count by 10% from your planned numbers listed herein. **The release of theatre seats must be done at least three weeks prior to your scheduled performance.**

Original Number of Tickets Booked : **25**

Minimum Tickets Required: **22**

- **Seating locations will be based on best available at the time of booking with initial deposit.**
- **Accessible seating requirements and special dietary requests must be arranged prior to the final payment.**
- Drury Lane offers wheelchairs and hearing devices, which are available at our Box Office on a first come first serve basis with a valid ID.
- Should you wish to increase your meal or ticket count after final payment, the request will be honored based on availability. Every effort will be made to keep your group together, however the theatre reserves the right to determine where additional seats will be located. Credit card payment is required for any add-on tickets.

- Drury Lane will hold performance and meal tickets at the Group Check-In Table for pick up on the day of the performance. Tickets are mailed only upon request. To ensure proper delivery, Drury Lane will not mail tickets within ten days of performance.
- Pricing is subject to change until a contract is issued. Prices freeze when Group Services receives a signed contract and initial deposit within the date listed on the contract. Price freeze does not pertain to Tax and Service fee.
- Please advise all members of your group that the Group Services department will only speak with the Group Leader indicated on your contract.
- **Tax Exemption**: If your organization is exempt from Illinois State Sales Tax, please attach a copy of your Illinois Exemption Letter. IF Drury Lane does not have a valid copy of this exemption letter, Illinois State Tax will be added to your final invoice. Please also keep in mind that all invoices must be addressed to the same organization listed on the exemption letter.

If your group is dining with us:

- Everybody in your group will receive the same first course and third course.
- The exact count of your entree must be given to the group services department three weeks prior to your event date as noted on this agreement.
- All meals are subject to Tax and Service fee.
- Tax and Service fees are subject to change.

Subtotal	1,921.20	Paid	0.00
Tax	0.00	Balance	2,086.80
Service Charge	165.60		
Total Value	2,086.80		

In the event of a cancellation, the 10% initial deposit is non-refundable or transferable.

Booked Date: July 18, 2024
 Signed Contract Return Due: August 1, 2024
 Initial Deposit Due: \$208.68 by August 1, 2024
 Final Attendance and/or Final Meal Selections Due: August 28, 2024
 Final Payment Due: September 4, 2024

I have read the above contract and agree to the terms and conditions as well as any terms and conditions on any contract addendum's which I may sign.

Client: _____

Date : _____

Sales Rep : _____

Date : _____

PARAMOUNT THEATRE GROUP DISCOUNT CONTRACT

PLEASE READ THIS CONTRACT CAREFULLY, SIGN AND RETURN,
TO THE ATTENTION OF MELISSA STRIEDL, ALONG WITH YOUR **DEPOSIT BY 07-31-24**.
CONTRACT OFFER IS NULL AND VOID IF NOT RETURNED BY AFOREMENTIONED DATE.

Performance Requested: *An Act of God* – Wednesday, October 16, 2024 at 1:30 p.m.
(In the COPLEY THEATRE, across the street from the Paramount Theatre)

Name of Organization: Forest Park Seniors # Buses _____

Group Coordinator: Brenda Powers

Address: 7640 Jackson Blvd. E-mail: bpowers@forestpark.net

City: Forest Park State: IL Zip: 60130

Telephone Number: 708-771-7737 Fax Number:

Requested Number of Tickets: 35 Price: \$47.75 (\$50.50 if final number is 10-19)

Total: \$1,623.50 30% Non-refundable Deposit: \$485.00

Final Count and Balance Due: Sept. 25, 2024 Balance: \$1,138.50

(There are no cancellations after this date. Groups are responsible for 80% of initial requested number and 100% of final count.)

A credit card number must be given at the time of order to establish an account and initiate seating. A 30% non-refundable deposit and signed contract are required to guarantee seating.

The Paramount Theatre reserves the right to make all seating assignments, and all performances are subject to change.

Groups will be seated for the performance date and time specified.

If tickets are added to a group we cannot guarantee that blocks of seats will be together. Group discounted price cannot be guaranteed for tickets purchased on the day of the performance.

All groups are responsible for 80% of initial number on this contract and, on the finalization date assigned, 100% of the final number confirmed. Seats will be released unless final payment is received by the balance due date.

Group rates are based on a minimum confirmed number and include \$1.00 for the Paramount Theatre Historic Preservation Fund. A minimum purchase of 20 tickets is required to receive a complimentary ticket. The Theatre Group Sales Manager in accordance with the Theatre Group Sales Policy must approve all special pricing. Should the final number be less than the number required for the quoted rate, the next appropriate prevailing rate will be charged.

All sales are final. There are no refunds, cancellations or exchanges. After finalization date, no reduction of group size will be accepted. There is a \$2.00 per ticket fee for lost tickets.

Twenty-four hour notice is required if payment is to be made in person.

IF PAYING BY CHECK, PLEASE MAKE PAYABLE TO: PARAMOUNT THEATRE
PAYMENT MAY BE SENT TO: PARAMOUNT THEATRE
ATTN: MELISSA STRIEDL
8 E. GALENA BLVD., SUITE 230, AURORA, IL 60506
PHONE: (630) 723-2461 FAX: (630) 892-1084

GROUP COORDINATOR: _____ DATE: _____

GROUP SALES MANAGER Melissa Striedl DATE: 6-28-24

for Act of God Oct 14, 2007 - 1:30pm

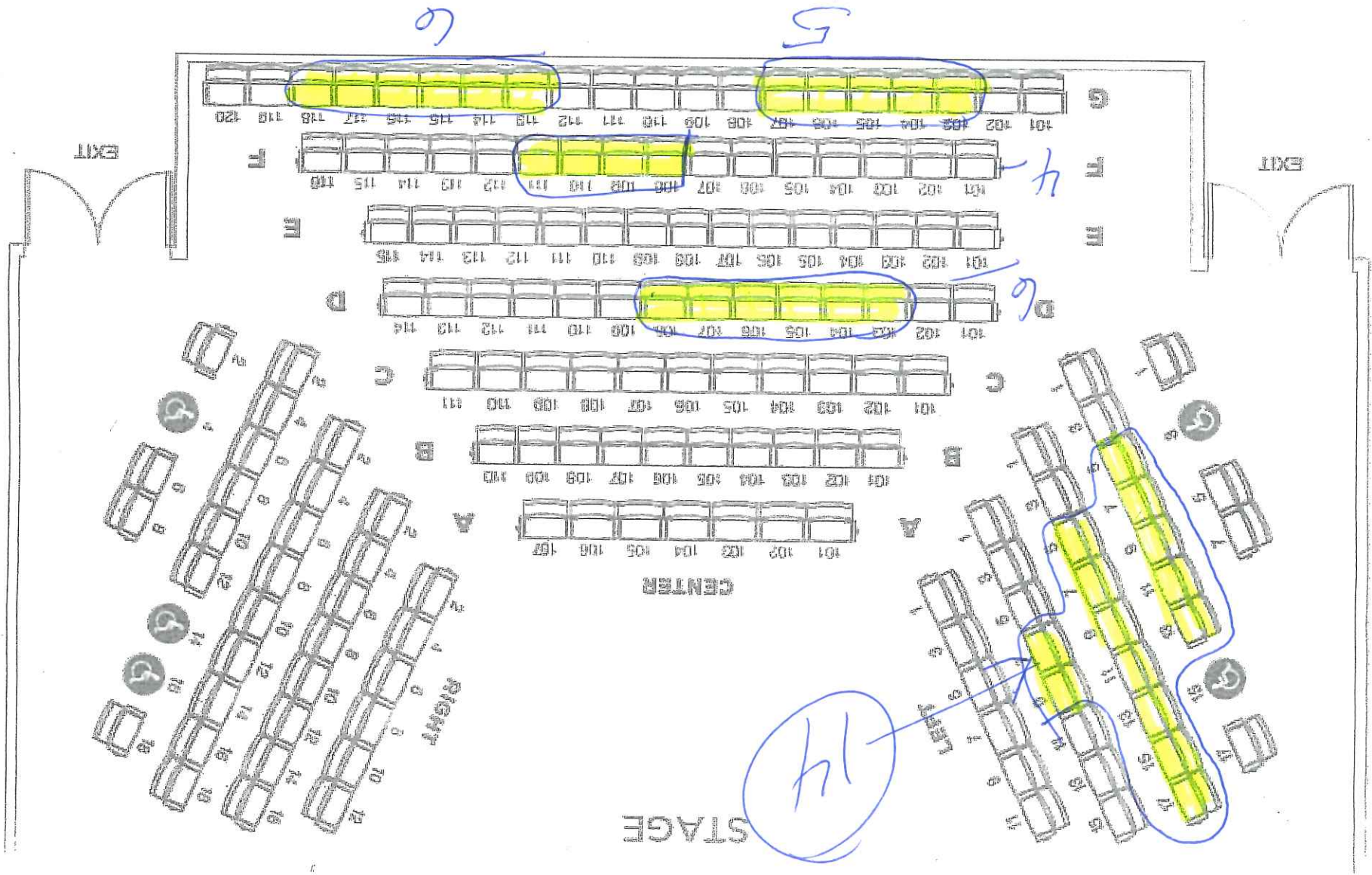

Forest Park Chamber of Commerce & Development
7331 W. Roosevelt Road
Forest Park, IL 60130
Phone (708) 366-2543 • Cell (708) 828-2158

Mayor Rory Hoskins
Village of Forest Park
517 Desplaines Avenue
Forest Park, IL 60130

July 30, 2024

Dear Mayor Hoskins & Commissioners:

On behalf of the Board of Directors of the Forest Park Chamber of Commerce and Madison merchants, I am requesting permission to host a Sidewalk Sale/Summer Sale on Madison Street August 22-25 as well as permission to hang two street banners.

Please let me know if have any questions or concerns. Thanks for your continued support.

Cc/Rachell Entler, Village Administrator
Cc/Vanessa Belmonte, Village Clerk

Sincerely,

A handwritten signature in cursive script that reads "Laurie Kokenes". The signature is fluid and includes a long horizontal flourish at the end.

Laurie Kokenes
Executive Director – Forest Park Chamber of Commerce



**APPLICATION FOR USE OF PUBLIC WAY
IN THE VILLAGE OF FOREST PARK, COOK COUNTY, ILLINOIS**

August 6th 2024
(Date)

INFORMATION:

Name of Entity Tool of North America

Street Address: 3205 Fujita Street Phone: (310) 453-9244

City, State, Zip Code: Torrance, CA 90505

Name of Owner: _____ Phone: ()

Person to Contact: Daniel Marcus - Location Manager Phone: (847) 722-4984

Type of Use Requested (i.e., Construction, Location, Size, Street/Parking Lot, etc.): _____

PARKING LOT / ALTENHIEM GRASSY FIELD

Schedule (Give dates and times, including set up and tear down): TUESDAY, AUGUST 13th 2024 • 6a- 10p

Proposed location (Include sketch of layout with measurements): See Attached Site Map

General description of use as well as any special requests: Parking for 75 Cars

ALTENHIEM PARKING - 7750 Van Buren St.



Anticipated needs of Village personnel, equipment and/or property: _____

N/A - Ideally it's mowed. I don't want to park on tall grass, to avoid chances of fire

INSURANCE:

No later than ten (10) days prior to the event, the Applicant shall furnish to the Village, a certificate of insurance evidencing commercial general liability insurance with minimum limits of One Million Dollars (\$1,000,000.00) combined single limit per occurrence and Two Million Dollars (\$2,000,000.00) general aggregate limits and otherwise reasonably satisfactory to the Village. The insurance policy shall be expressly endorsed to include the Village, as additional insured as outlined below. Such insurance shall be maintained during the term of use.

Such certificate shall include the following language: "The Village of Forest Park, its corporate authorities, officers, officials, boards, commissions, employees, attorneys, agents and representatives are made additional insured with respect to any and all claims which arise out of, or are in any way related to, the operations of (entity name) while present in the Village of Forest Park."

The Applicant shall also attach proof that the appropriate workers compensation and employer's liability insurance have been provided for the employees of the requesting entity.

Certificate attached DM
(initials)

INDEMNITY AGREEMENT:

The Applicant shall sign a Non-Exclusive Permit and Indemnity Agreement with the Village of Forest Park holding the Village harmless of any claim that may arise from their use of designated public property, right-of-way, or equipment in conjunction with the permitted use.

SURETY BOND REQUIRED

In addition to the foregoing requirements, the applicant shall, as a part of his application, deposit with the village clerk a surety bond in the amount of ten thousand dollars (\$10,000.00) as security for the payment of any damage which may result to such public way, public park or public building by reason of the applicant's use of the same pursuant to a permit to be issued herein. Any part of said deposit not needed or used to repair, replace or restore damage so occasioned to public property by the applicant at the end of the permit period shall be returned to the applicant within ten (10) days after the expiration date.

MISCELLANEOUS:

Specify any other circumstances, conditions, or anticipated needs not covered in this application: _____



CERTIFICATE OF LIABILITY INSURANCE

DATE (MM/DD/YYYY)
08/06/2024

THIS CERTIFICATE IS ISSUED AS A MATTER OF INFORMATION ONLY AND CONFERS NO RIGHTS UPON THE CERTIFICATE HOLDER. THIS CERTIFICATE DOES NOT AFFIRMATIVELY OR NEGATIVELY AMEND, EXTEND OR ALTER THE COVERAGE AFFORDED BY THE POLICIES BELOW. THIS CERTIFICATE OF INSURANCE DOES NOT CONSTITUTE A CONTRACT BETWEEN THE ISSUING INSURER(S), AUTHORIZED REPRESENTATIVE OR PRODUCER, AND THE CERTIFICATE HOLDER.

IMPORTANT: If the certificate holder is an **ADDITIONAL INSURED**, the policy(ies) must be endorsed. If **SUBROGATION IS WAIVED**, subject to the terms and conditions of the policy, certain policies may require an endorsement. A statement on this certificate does not confer rights to the certificate holder in lieu of such endorsement(s).

PRODUCER Marsh USA Inc. 633 West 5 th Street Los Angeles, CA 90071 Stagwell Global LLC /DONER	CONTACT NAME: Entertainment Practice	
	PHONE (A/C, No, Ext):	FAX (A/C, No):
	EMAIL ADDRESS: adwrap@marsh.com	
	INSURER(S) AFFORDING COVERAGE	
	INSURER A: Fireman's Fund Insurance Company	NAIC # 21873
	INSURER B: General Star National Insurance Co.	11967
	INSURER C:	
	INSURER D:	
	INSURER E:	
	INSURER F:	

COVERAGES	CERTIFICATE NUMBER:	REVISION NUMBER:
------------------	----------------------------	-------------------------

THIS IS TO CERTIFY THAT THE POLICIES OF INSURANCE LISTED BELOW HAVE BEEN ISSUED TO THE INSURED NAMED ABOVE FOR THE POLICY PERIOD INDICATED. NOTWITHSTANDING ANY REQUIREMENT, TERM OR CONDITION OF ANY CONTRACT OR OTHER DOCUMENT WITH RESPECT TO WHICH THIS CERTIFICATE MAY BE ISSUED OR MAY PERTAIN, THE INSURANCE AFFORDED BY THE POLICIES DESCRIBED HEREIN IS SUBJECT TO ALL THE TERMS, EXCLUSIONS AND CONDITIONS OF SUCH POLICIES. LIMITS SHOWN MAY HAVE BEEN REDUCED BY PAID CLAIMS.

INSR LTR	TYPE OF INSURANCE	ADDL INSR	SUBR WVD	POLICY NUMBER	POLICY EFF (MM/DD/YYYY)	POLICY EXP (MM/DD/YYYY)	LIMITS
A	GENERAL LIABILITY <input checked="" type="checkbox"/> COMMERCIAL GENERAL LIABILITY <input type="checkbox"/> CLAIMS-MADE <input checked="" type="checkbox"/> OCCUR <input type="checkbox"/> _____ <input type="checkbox"/> _____ GEN'L AGGREGATE LIMIT APPLIES PER: <input type="checkbox"/> POLICY <input checked="" type="checkbox"/> PRO-JECT			UST008472240	3/31/2024	3/31/2025	EACH OCCURRENCE \$1,000,000 DAMAGE TO RENTED PREMISES (Ea occurrence) \$1,000,000 MED EXP (Any one person) \$10,000 PERSONAL & ADV INJURY \$1,000,000 GENERAL AGGREGATE \$2,000,000 PRODUCTS - COMP/OP AGG \$1,000,000
A	AUTOMOBILE LIABILITY <input type="checkbox"/> ANY AUTO <input type="checkbox"/> ALL OWNED AUTOS <input type="checkbox"/> SCHEDULED AUTOS <input checked="" type="checkbox"/> HIRED AUTOS <input checked="" type="checkbox"/> NON-OWNED AUTOS <input type="checkbox"/> _____ <input checked="" type="checkbox"/> NOHA PHYS. DMG.			UST008472240	3/31/2024	3/31/2025	COMBINED SINGLE LIMIT (Ea accident) \$1,000,000 BODILY INJURY (Per person) BODILY INJURY (Per accident) PROPERTY DAMAGE (Per accident)
A	<input checked="" type="checkbox"/> UMBRELLA LIAB <input checked="" type="checkbox"/> OCCUR <input type="checkbox"/> EXCESS LIAB <input type="checkbox"/> CLAIMS-MADE <input type="checkbox"/> DED <input type="checkbox"/> RETENTION \$			UST004982241 NXG930342	3/31/2024	3/31/2025	EACH OCCURRENCE \$19,000,000 AGGREGATE \$19,000,000
B	WORKERS COMPENSATION AND EMPLOYERS' LIABILITY ANY PROPRIETOR/PARTNER/EXECUTIVE OFFICER/MEMBER EXCLUDED? (MANDATORY IN NH) If yes, describe under DESCRIPTION OF OPERATIONS below		N/A	Not Included	N/A	N/A	<input type="checkbox"/> WC STATU-TORY LIMITS <input type="checkbox"/> OTH-ER E.L. EACH ACCIDENT E.L. DISEASE - EA EMPLOYEE E.L. DISEASE - POLICY LIMIT
A	PROPS, SETS & WARDROBE MISCELLANEOUS EQUIPMENT THIRD PARTY PROPERTY DAMAGE			UST008467240	3/31/2024	3/31/2025	LIMIT - \$5,000,000 DED:\$2,500 LIMIT - \$5,000,000 DED:\$3,500 LIMIT - \$1,000,000 DED:\$2,500

DESCRIPTION OF OPERATIONS / LOCATIONS / VEHICLES (Attach ACORD 101, Additional Remarks Schedule, if more space is required)
 Certificate Holder is included as Additional Insured and/or Loss Payee as respects operations of the Named Insured and as required by contract.
 *Cover is All risks, Worldwide, In-Transit with Replacement Costs on Misc Rented Equipment.
 *Cover is Primary and Non-Contributory and Waiver of Subrogation Applies. Policy does not include an Unattended Vehicle Exclusion.
 Coverage applies to production entitled: "Holiday & Megabrand Production"; Job No.: MEIJRG1002400035; Client: Meijer.

CERTIFICATE HOLDER	CANCELLATION
Village of Forest Park 517 Desplaines Ave Forest Park, IL 60130	SHOULD ANY OF THE ABOVE DESCRIBED POLICIES BE CANCELLED BEFORE THE EXPIRATION DATE THEREOF, NOTICE WILL BE DELIVERED IN ACCORDANCE WITH THE POLICY PROVISIONS. AUTHORIZED REPRESENTATIVE <i>Aaron Baum</i>

Non-Exclusive Permit and Indemnity Agreement

This Non-Exclusive Permit and Indemnity Agreement is made and entered into on this 6th day of AUGUST, 2024, by and between the Village of Forest Park, Illinois, an Illinois municipal corporation (herein referred to sometimes as “Village”) and TOOL of North America, (herein referred to as “Applicant”).

Applicant desires to enter onto and utilize a certain portion of the Village public property, right of way, and/or equipment (hereinafter referred to as “Village Property”), for the limited purpose of PARKING VEHICLES (“Purpose”), and the Village is willing to grant Applicant a non-exclusive and temporary permit to do so, on the terms and conditions set forth below. In signing this document, Applicant acknowledges that the Village would not allow such a use unless Applicant fully recognizes and assumes the existence of risks that exist with operating such a use and abides by the regulations and limitations as may be imposed by the Village.

Village hereby grants Applicant and its invitees, employees, volunteers, representatives and agents (collectively, the “Users”), a temporary, non-exclusive permit to enter on the Village Property for the limited purpose of utilizing the Village Property for said Purpose, subject to the following terms and conditions:

(1) TERM. The term of this Permit shall be 1 day(s), beginning August 13th, 2024, at 6 a.m./p.m., and ending August 13th, 2024, at 10 a.m./p.m. (the “Permit Term”).

(2) RESTRICTION ON USE. Applicant and Users shall solely use the Village Property for the limited purpose of said Purpose. The Applicant shall not alter the Village Property in any fashion without the written consent of the Village. The Applicant’s use of the Village Property shall not be exclusive and shall not interfere with the Village’s use of or access to the Village Property.

Applicant shall not carry on, upon the Village Property, or any part thereof, or permit to be carried on, any trade, business or use of an unsafe or unhealthful nature, or which shall constitute a nuisance. Applicant shall not use, or permit to be used, said Village Property, or any part thereof, for any illegal, immoral, or adult business (as defined in the Municipal Code of the Village of Forest Park) or purpose whatsoever. Applicant and Users shall comply with the requirements of the Village of Forest Park Police and Fire Departments in conducting said Purpose and shall confer with said departments to ensure safety and compliance with all Village Ordinances.

(3) CONDITION; MAINTENANCE; REPAIR. Applicant accepts the Village Property in its current condition and Village makes no representations concerning the condition of the Village Property. Village has no duty or obligation to maintain or repair the Village Property during the Permit Term. Further, Village shall not be liable to Applicant or Users for any damage or injury to any of them or their property occasioned by the failure of the Village to keep the Village Property maintained and in repair. Except as approved by the Village, Applicant and Users shall not attach, affix or exhibit or permit to be attached, affixed or exhibited to the Village Property any articles of permanent or semi-permanent character.

(4) ASSUMPTION OF RISK. Applicant and Users shall use the Village Property at their own risk and Village shall not be liable for any damage to person or property resulting, directly or indirectly, from Applicant's and Users' use of the Village Property.

(5) INSURANCE AND INDEMNIFICATION. Applicant shall indemnify and save harmless Village and its officials, officers, employees, staff, contractors, agents, representatives, consultants, successors and assigns (collectively, the "Indemnitees"), from and against any and all losses, damages, claims, actions, liabilities, costs and expenses including, without limitation, attorneys' fees and expenses, that the Indemnitees may suffer, incur or sustain arising out of or relating to the activities of Applicant or the Users of the Village Property for said Purpose or work, or any invitees thereof, under this Permit, or any acts or omissions of Applicant or its contractors, agents, employees, tenants, invitees or representatives hereunder; or with respect to or arising out of any use of the Village Property or the rights herein granted, or the performance or non-performance of Applicant's obligations hereunder.

Applicant hereby covenants and agrees that Indemnitees shall not be liable for any damages arising from personal injury or damage to property which may be sustained in any way in, on or about the premises where the said Use or Work is occurring. Applicant will assume full responsibility for any such injuries or damages and hereby fully and forever releases and discharges the Indemnitees from any and all claims, demands, damages, rights or actions or causes of action present or future whether the same be known, anticipated or unanticipated resulting from or arising out of the Use, Purpose or Work on the Village Property.

While conducting said Purpose or Work, Applicant and Users will adhere to the rules and regulations conveyed to Applicant by the Village. In the event that the actions of Applicant and/or Users results in injuries to person or property and a claim is made against the Village, its officials, officers, employees, staff, contractors, agents, representatives, consultants, successors and assigns, Applicant will hold harmless, defend and indemnify the Village and its officials, officers, employees, staff, contractors, agents, representatives, consultants, successors and assigns against any claim, demand, damage, right of action present or future, whether the same be known, anticipated or unanticipated, resulting from the Users.

No later than one (1) days prior to the Users conducting said Purpose or work, the Applicant shall furnish to the Village, a certificate of insurance evidencing commercial general liability insurance with minimum limits of One Million Dollars (\$1,000,000.00) combined single limit per occurrence and Two Million Dollars (\$2,000,000.00) general aggregate limits and otherwise reasonably satisfactory to the Village. The insurance policy shall be expressly endorsed to include the Village, as additional insured, as outlined in the Application for Use of Public Way. Such insurance shall be maintained during the Permit Term.

(6) HAZARDOUS WASTE, SUBSTANCES, MATERIALS; EXPLOSIVES. Applicant shall not store, house, possess or permit any hazardous waste, hazardous substances, hazardous materials, or explosives, upon the Village Property, or any part thereof.

(7) ZONING. Nothing contained herein shall be construed as the Village's approval or granting of any zoning or permit requirements, application or petition.

(8) REVOCATION. This Permit and any rights granted herein may be revoked by the Village at any time

(9) ENFORCEABILITY. This Agreement may be enforced either at law or in equity. If any term, covenant or condition of this Agreement or the application thereof to any person or circumstance shall, to any extent, be invalid or unenforceable, the remainder of this Permit, or the application of such term, covenant or condition to persons or circumstances other than those as to which it is held invalid or unenforceable, shall not be affected thereby, and each term, covenant and condition of this Agreement shall be valid and enforceable to the fullest extent permitted by law.

VILLAGE

Village of Forest Park, an Illinois municipal corporation

By: _____
Rory E. Hoskins, Mayor

Attest: _____
Vanessa Moritz, Village Clerk

APPLICANT

Name: _____

By: Daniel Marcus - Location Manager & Agent for Tool

The entity or representative shall sign this application and upon favorable consideration of this application, the Village shall issue a permit for the requested activity subject to the aforesaid conditions and any others as may be reasonably required.

CASH DEPOSIT:

In lieu of the Surety Bond requirement, the applicant, prior to the issuance of any permit hereunder shall deposit with the village a cash deposit in the sum of ten thousand dollars (\$10,000.00) to ensure that no damage will be done to the adjoining streets, sewers, trees or adjoining properties and that all residual debris, trash and materials will be removed following the use. Such deposit shall be returned to the applicant upon the certification by the Director of Public Works or Public Health and Safety that all conditions of the permit have been complied with and that no damages occurred as a result of the use of the public way by the applicant.

FEES AND REMUNERATION:

The fee for processing and issuing the permit for the use of the public way shall be fifty dollars (\$50.00). In addition, the cost for the use of police, public safety, public works or other village personnel, the use of village equipment and public property shall be as outlined in section 7-2 of the municipal code.

I have read, understand and agree to abide by the terms and conditions of Title 7, Chapter 2, Section entitled "Private Use of Public Ways" of the Municipal Code of the Village of Forest Park, Cook County, Illinois.



 Signature

LAURIE KOKENES

 Print Name

Executive Director

 Title

_____ Date

APPROVED:

 Village Clerk Date



Bishop Ketteler Council #1628
Joshua Kowal, ID Drive Chairman
40 E. Burlington St, Riverside, IL 60546
<https://www.stpaulviparish.org/>

July 21, 2024

Council Members
Village of Forest Park, IL
Forest Park, IL

The Knights of Columbus Bishop Ketteler Council #1628, operates as an organization that supports the needs of St. Paul VI Parish, as well as the general surrounding community. At the request of Fr. Tom May, Pastor of St. Paul VI, in the winter of 2012 a group of our parish men reactivated our council, which was originally chartered on April 12, 1912. Our charge is simply to help those in need.

The annual Knights of Columbus Intellectual Disability Drive (Tootsie Roll Drive) has been a key fundraising initiative for over 40 years. Now, as Council 1628 again becomes actively involved in this endeavor we are searching for potential fundraising locations that are currently not being staffed by other K of C Councils, so as not to encroach on them.

We request permission to solicit at the following locations on Friday 9/6/2024 and Saturday 9/7/2024:

- Roosevelt on Desplaines southbound lane
- Roosevelt on Desplaines northbound lane
- Desplaines on Roosevelt westbound lane
- Desplaines on Roosevelt eastbound lane
- Jackson on Circle southbound lane
- Jackson on Circle northbound lane
- Circle on Jackson eastbound lane
- Circle on Jackson westbound lane

All funds collected during this drive, minus out of pocket expenses such as cost of the Tootsie Rolls, are earmarked for St. Paul's SPRED group, Misericordia, Seguins, WSSRA, CSS, and other similar groups that have a mission to help community members who have intellectual disabilities. Should you or any council members have any questions please do not hesitate to contact me at [REDACTED]

Kind regards,

Joshua Kowal
Intellectual Disability Drive Chairman

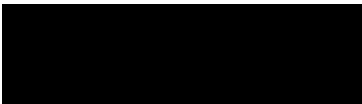

July 25th, 2024

The Forest Park Theatre requests 2 banners to be hung to promote the upcoming Free Shakespeare performance of Pericles. We would like to request the following:

- 1 banner hung on Madison (location preference Madison and Circle)
- 1 banner hung on Roosevelt (no location preference)
- Dates requested - August 1 - August 18th.

Pericles will be performed in the field behind the Altenheim, August 9-11 and 16 - 18. All performances start at 5pm and are free. Thank you for your continued support of the Forest Park Theatre.

As a reference, we are including a picture of the banner.



Sincerely,

Richard Corley
Artistic Director
Forest Park Theatre
www.fptheatre.org